



Si-52C

# **VRV System**

**Design & Installation Instruction**

**Inverter K Series**

**PLUS Series**

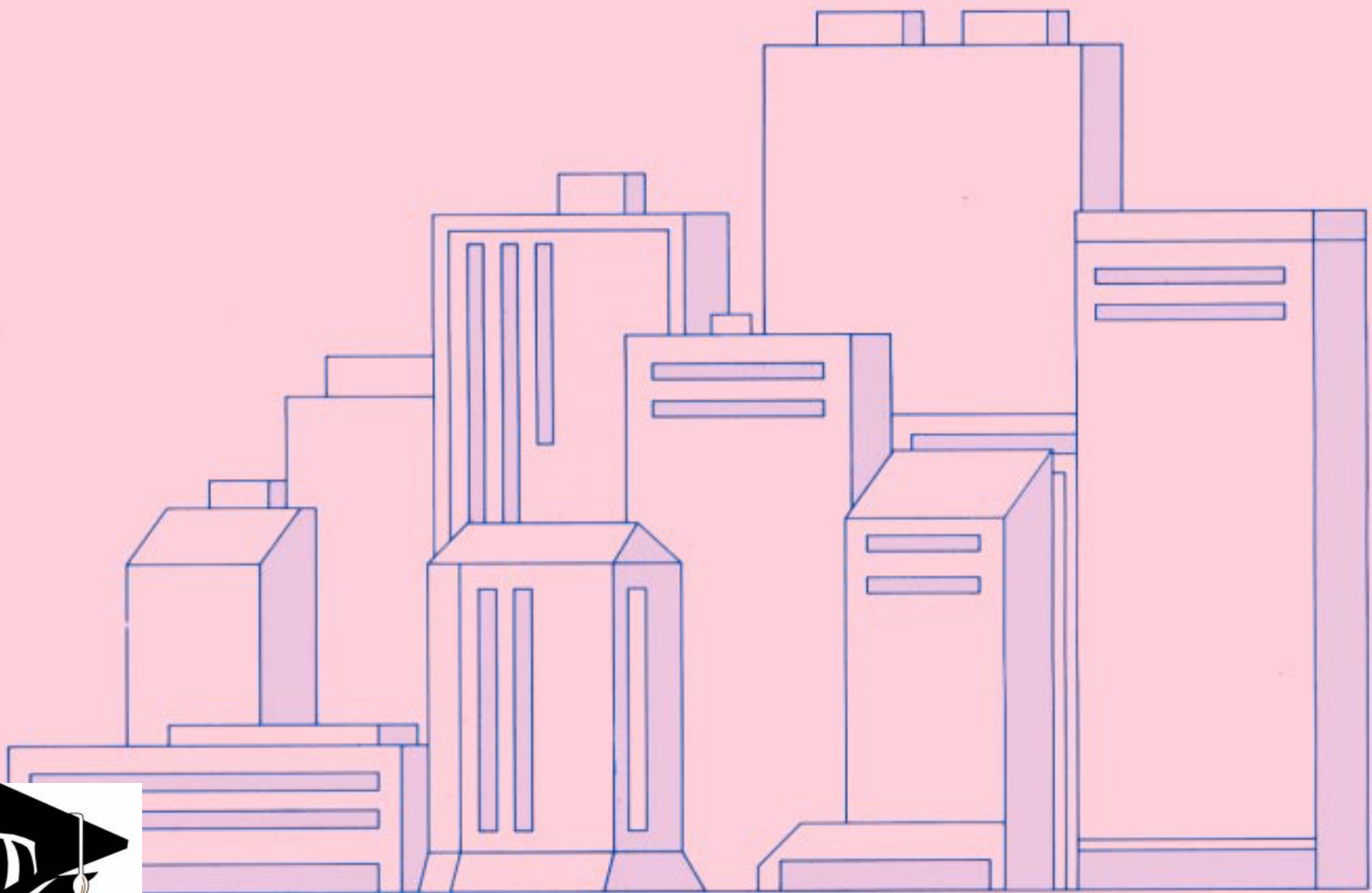

**Большая библиотека технической документации**

<https://splitsystema48.ru/instrukcii-po-ekspluatacii-kondicionerov.html>

**каталоги, инструкции, сервисные мануалы, схемы.**

## Preface

This system is a modular zone controllable air conditioning system of great sophistication which is capable of assembly in a variety of different configurations. It would, however, be no exaggeration to say that the full potential of the system's functions can only be achieved in combination with the skills of those involved in the design of the equipment itself and those responsible for the installation work at the local level.

As the move towards intelligent buildings has gathered momentum, so we have also been seeing ever more a growing demand for a wider range of independently controllable building related functions.

Against this background there have also quite naturally been calls for the development of more distributed types of air conditioning systems while at the same time taking full account of the need to use energy economically by demand matching in view of the huge annual increases in the demand for electric power seen in recent years.

We have therefore prepared this installation manual to enable installation work to be handled confidently on the basis of a clear understanding of the special features of this system. We have paid particular attention to points of difference in installation procedure between this system and the more traditional package and room air conditioning system.

The manual is designed specifically to cater for those supervising installation work and concentrates on those products which are currently on the market. Essential points which need to be taken into consideration when designing an appropriate configuration for the system and in each of the separate installation processes have also been included.

We have also added a section covering problems which have arisen in connection with installation work undertaken to date in an attempt to prevent the recurrence of the same problems.

Please therefore make full use of this manual in order to gain a complete insight into all the more important points relating to the installation of this system so that the enormous potential of its multi-functional design may be fully realized.

Please be sure to read this manual thoroughly before starting installation work in order to ensure that all such work is carried out with maximum efficiency and to maximum effect.

"System design materials" are published separately by way of technical back-up for each series of this system and the following set of manuals is intended as a comprehensive supplement to the whole series.

- |   |  |
|---|--|
| <b>(1) Engineering Data</b>   | <b>CED97-2-1 (K series), CED97-2-2 (PLUS series)</b> |
| <b>(2) Option Handbook</b>  | <b>Si-03</b>   |
| <b>(3) Service Manual</b>   | <b>Si-05B</b>  |
| <b>(4) Installation &amp;<br/>Operation Manual<br/>&lt;Combined Version&gt;</b> | <b>Si-60</b>   |

# CONTENTS

## I **VRV K Series**

<b>General</b> .....	<b>1</b>
1. What is VRV-System? .....	1
2. The installation is of vital importance .....	2
<b>1 Points to bear in mind at the system design</b> .....	<b>3</b>
1.1. Points relating to the performance of the air conditioning units .....	3
1.2. Striking a balance between system installation and general construction work (comprehensive flow chart) .....	4
1.3. Points to bear in mind when preparing the contract drawings .....	5
<b>2 Installation</b> .....	<b>8</b>
2.1. Step by step installation procedure .....	8
2.2. Work involved in individual operations and points to be borne in mind .....	9
(1) Sleeve and insert work .....	9
(2) Installation of indoor unit .....	10
(3) Refrigerant pipe work .....	11
(4) Drain pipe work (indoor) .....	19
(5) Electrical work .....	30
(5)-1. Control wiring .....	30
(5)-2. Power supply (cabling of main power supply) .....	32
(6) Duct work (indoor) .....	34
(7) Thermal insulation work (refrigerant piping) .....	35
(8) Installation of outdoor unit .....	36
(9) Air tight test .....	41
(10) Vacuum drying .....	43
(11) Additional charge of refrigerant .....	46
(12) Field settings .....	49
(13) Test run adjustment .....	57
(14) Caution for refrigerant leaks .....	59
(15) Hand over to customer .....	61
<b>3 Bad examples and good examples in installation</b> .....	<b>62</b>
<b>Appendix</b> .....	<b>71</b>
1. Operating noise of indoor units .....	72
2. Procedures for rigging refrigerant piping .....	74
3. Piping system diagrams and refrigerant piping work for the Inverter K Series .....	78
4. Locating outdoor units .....	83
5. Precaution in control wiring work .....	84
6. Check this before performing a test run .....	86

## II ***VRV* PLUS Series**

<b>1 Outline of system</b>	<b>94</b>
<b>2 Allowable piping length</b>	<b>95</b>
<b>3 How to install outdoor units and function unit</b>	<b>96</b>
<b>4 Unit combinations</b>	<b>97</b>
<b>5 Selection of refrigerant pipe</b>	<b>98</b>
<b>6 Nitrogen replacement</b>	<b>100</b>
<b>7 Brazing</b>	<b>101</b>
<b>8 Covering of refrigerant pipes</b>	<b>102</b>
<b>9 Flushing</b>	<b>103</b>
<b>10 Air tight test</b>	<b>104</b>
<b>11 Vacuum drying</b>	<b>106</b>
<b>12 Additional charge of refrigerant</b>	<b>108</b>
<b>13 Electrical work for power supply</b>	<b>114</b>
<b>14 Electrical work for transmission line</b>	<b>115</b>
<b>15 Switch setting according to No. of outdoor unit</b>	<b>116</b>
<b>16 Test operation</b>	<b>117</b>
(1) Procedure and points	117
(2) Action when power on	118
(3) Function unit / Outdoor unit PC board Ass'y	119
(4) Setting modes	120
(5) Sequential start	126
(6) External control adaptor for outdoor unit (DTA104A61·DTA104A62)	127
(7) Cool / Heat mode selection	129
(8) Low noise operation	133
(9) Demand control	134
(10)Wiring check operation	135
<b>17 Installation examples</b>	<b>139</b>
<b>Appendix</b>	<b>146</b>
1.Selection of vacuum pump	146
2. <i>VRV</i> inspection sheet	148
3.Refrigerant piping diagram for PLUS series	152
4.REFNET pipe component for PLUS series	159

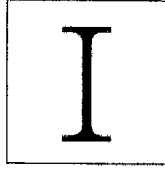

# ***VRV* K Seiries**

# General

## 1. What is "VRV System"?

It is an air conditioning system for commercial building application with sophisticated individual zone control. As you see from the figure shown below, it can be used for various applications with a broad range of flexibility. The major differences between conventional air cooled packaged air conditioners are shown as follows:

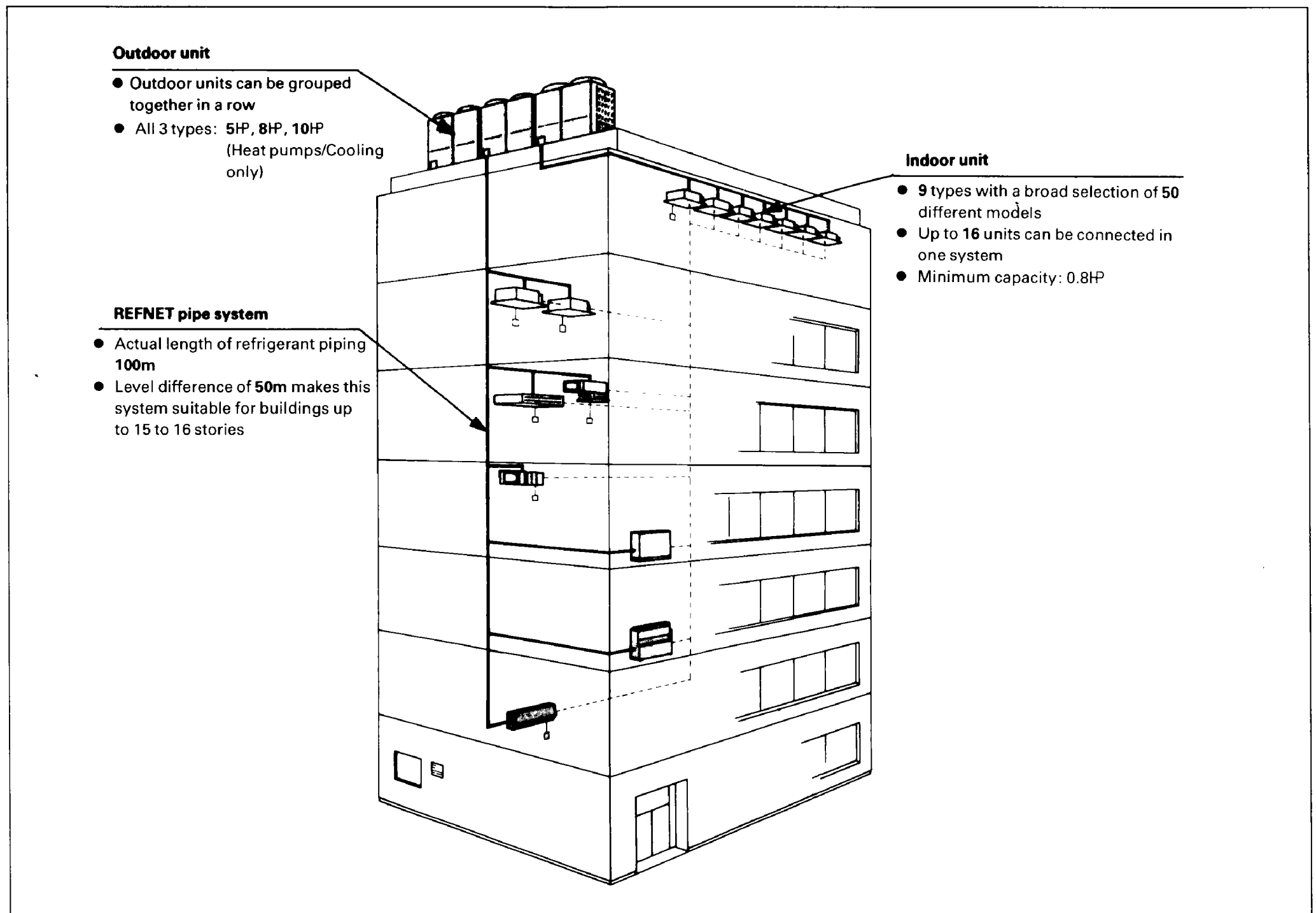

### For example: Inverter K series

(1) Up to a maximum of 16 indoor units of different capacities and types can be connected to 1 refrigerant system.

**AFTER THE INSTALLATION IS FINISHED, REFRIGERANT PIPING AND ELECTRIC WIRING MUST BE CHECKED UNIT BY UNIT TO PREVENT WRONG CONNECTION.**

(2) Up to 100m maximum of actual piping length is possible.

- \* **PROPER MEASURES MUST BE TAKEN TO PREVENT TUBES FROM GETTING CONTAMINATED OR MOISTENED.**
- \* **WHEN BRAZING, NITROGEN GAS MUST BE PASSED THROUGH TUBES TO PREVENT OXIDIZATION.**

(3) Many different control circuits can be selected to meet a wide range of application requirements.

**USE PROPER WIRES FOR CONTROL CIRCUIT LINES, BECAUSE THE CONTROL SYSTEM IS HIGHLY SOPHISTICATED WITH 2 WIRE-MULTIPLEX TRANSMISSION SYSTEM.**

(4) Installation job is more complicated

- \* ALL JOBS ON THE SITE SUCH AS INITIAL SETTING OF SWITCHES ETC. MUST BE LISTED UP AND SCHEDULED IN ADVANCE.
- \* REFRIGERANT TUBE LENGTH TO EACH UNIT AND REFRIGERANT CHARGE AMOUNT MUST BE ACCURATELY RECORDED FOR THE FUTURE SERVICE.

The "VRV System" functions properly if the installation is done properly, however, the opposite can also be true. It must be remembered that the quality of installation is EXTREMELY IMPORTANT!

## 2. The installation is of vital importance

The analysis of major installation problems experienced during the year of 1988 is shown below;

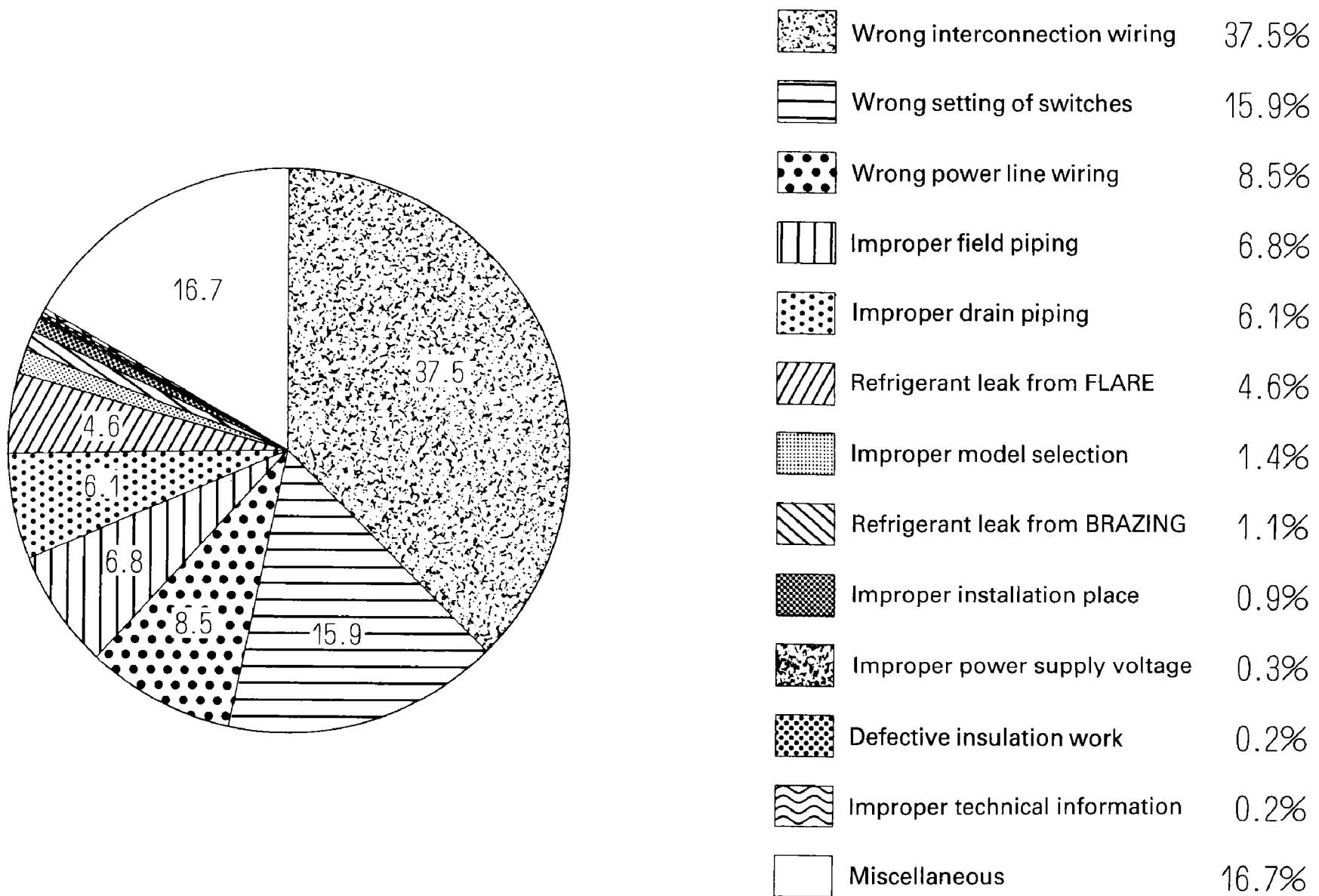

How these installation problems affect an equipment are shown below:

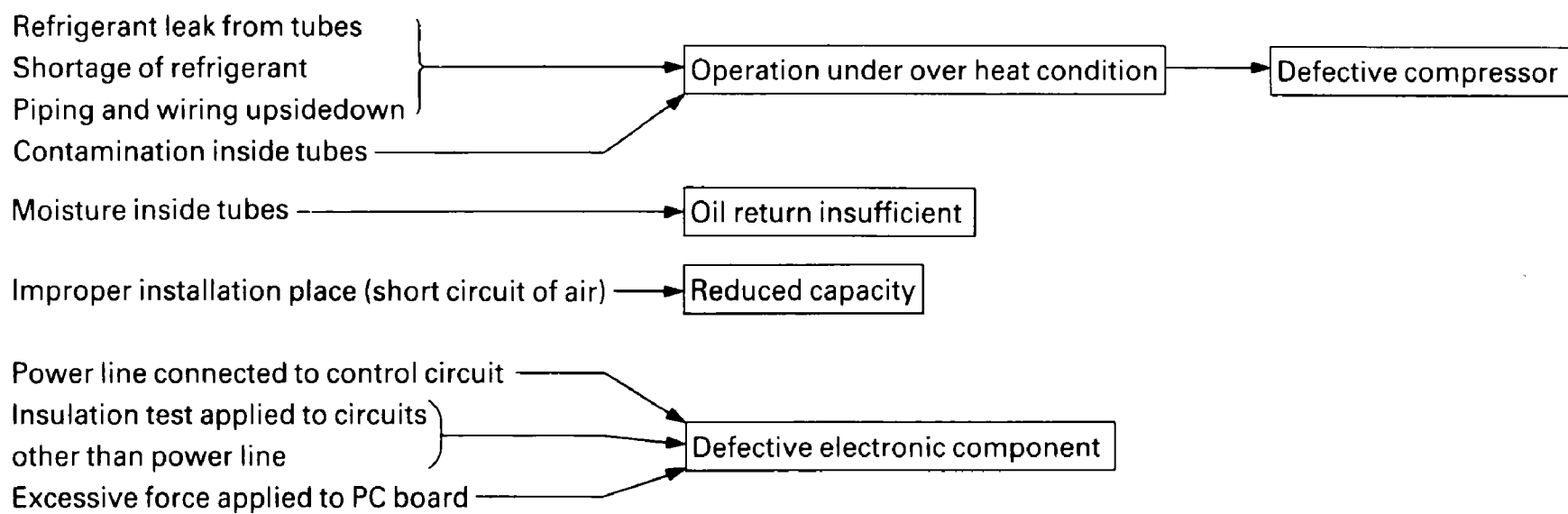



# 1. Points to bear in mind at the system design

## 1.1. Points relating to the performance of the air conditioning units

A number of points need to be borne in mind at the system design stage in order to ensure the mechanical efficiency of the air conditioning units.

1) Path of refrigerant piping between outdoor and indoor units, height difference and pipe length.

- Path of refrigerant piping should be determined such that length of piping is kept to a minimum.
- Piping should be kept within permissible limits in terms of length and height difference.

2) Positioning of outdoor unit

- Position such that maintenance and repairs can be carried out. (leave room for servicing)
- Avoid reduction of airflow and short circuiting

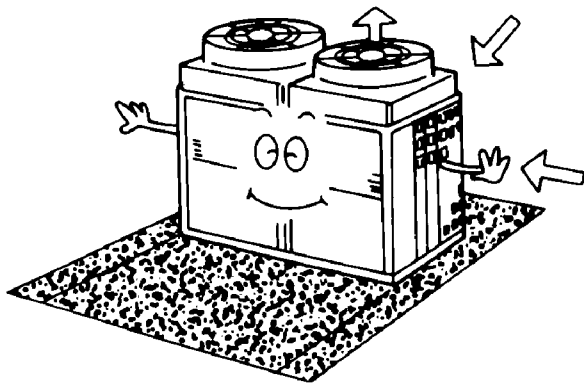

- Avoid reduction of airflow and short circuiting

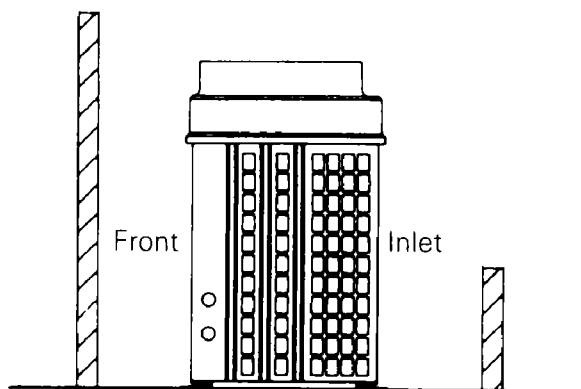

3) Positioning of indoor unit

- Position such that maintenance and repairs can be carried out. (inspection port positions and size check)
- Avoid short circuiting
- Ensure sufficient drain pipe gradient (need for drain-up kit etc.)
- In the case of a ceiling mounted type make sure ceiling depth is sufficient (need for high performance filter, etc.)

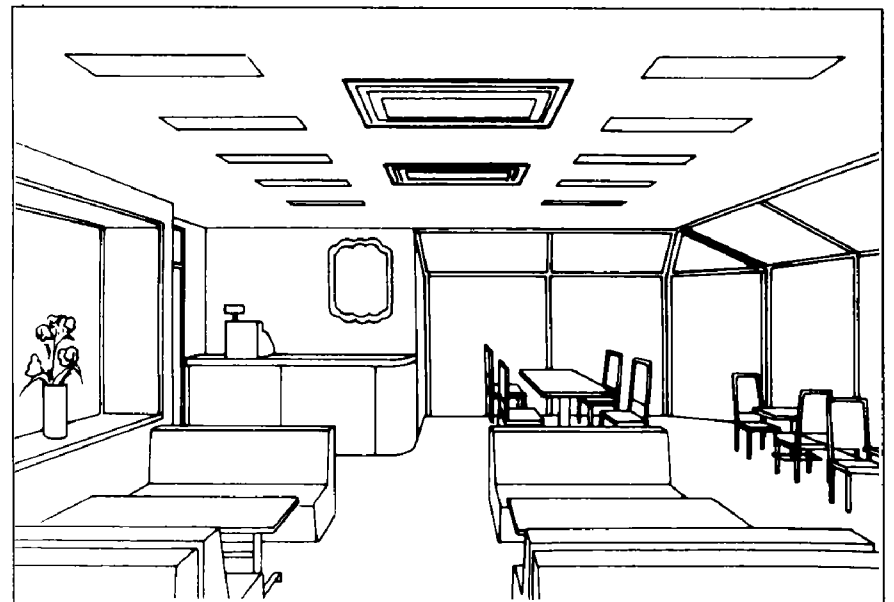
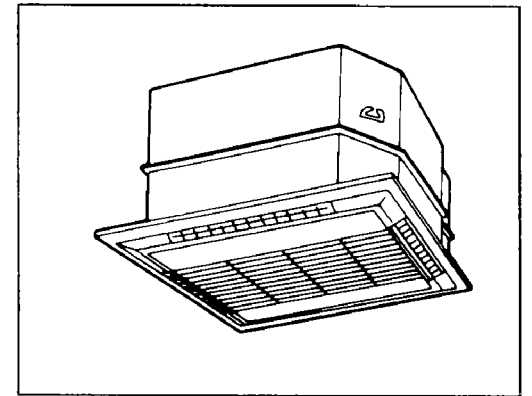

## 1.2. Striking a balance between system installation and general construction work (comprehensive flow chart)

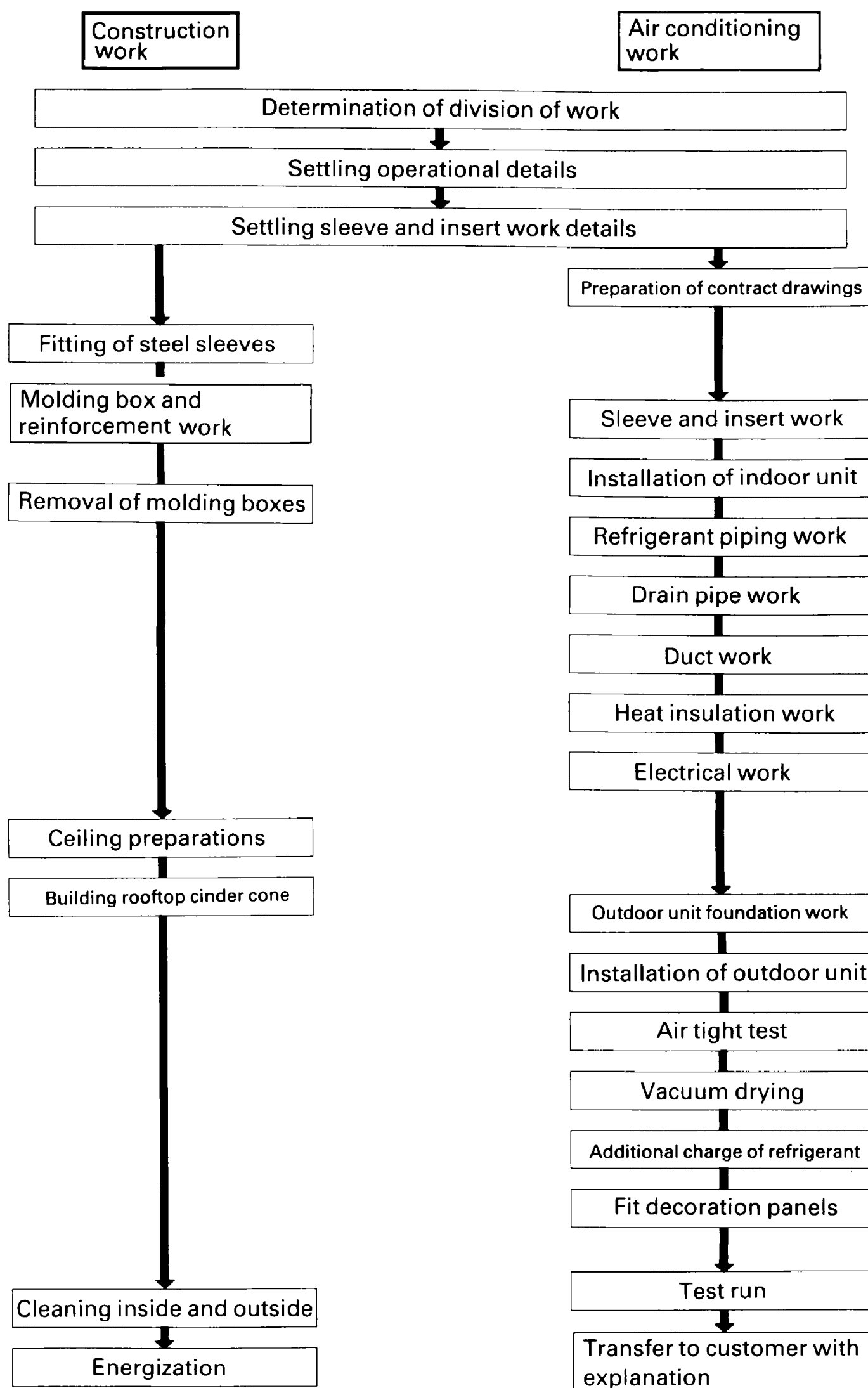

### Note:

1. The division of the work should be thoroughly clarified. (This applies particularly to work relating to the connection of control wiring, fitting of remote controller and central control panel, boundary work on areas such as connection of drain piping and humidification supply piping, inspection and foundation)
2. Keep a constant check on the progress of the construction work to avoid deviations from the air conditioning work schedule.
3. For sleeve and insert work the positions of ceiling girders should be confirmed and sleeve and insert requirement, hole diameters, positioning and numbers decided. This is particularly important in the case of sleeves for drain piping.

### 1.3. Points to bear in mind when preparing the contract drawings

The following points should be borne in mind when preparing the contract drawings from the original drawings and the execution drawings.

The contract drawings for the air conditioning system are blueprints for the performance of the necessary work which are drawn up on the basis of the original drawings in such a way that a working balance is achieved between the specific requirements of each individual aspect of the work.

#### 1. Contract drawing

Objectives include:

- The drawings should be easily comprehensible to those carrying out the work.
- The contents of the drawings should not be subject to subsequent alteration.

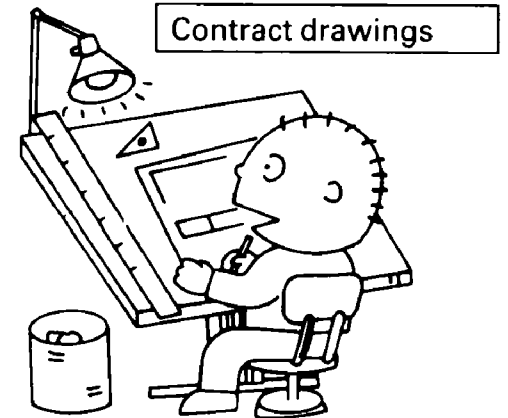

The following is a list of the main points to be considered when preparing contract drawings for the **VRV** System and should be used as a reference during this stage of the work:

#### (1) At the contract drawing stage the following points are critical!!

	Check points
Arrangement of units	<ol style="list-style-type: none"> <li>① Have you left the access passages clear and allowed sufficient room for servicing?</li> <li>② Have you taken full account of the possibility of short circuits? (Both indoor and outdoor units)</li> <li>③ Can the air filters be replaced easily?</li> <li>④ Have you indicated the size and location of the ceiling inspection ports? (Make sure there no other installations in the area above)</li> <li>⑤ Have you taken into account the depth of the installation area? (In case of ceiling built-in type)</li> <li>⑥ Have you specified the position of the indoor unit clearly? (Have you taken full account of relevant features of the local ventilation, humidity and lighting?)</li> </ol>
Refrigerant piping	<ol style="list-style-type: none"> <li>① Is the piping system correctly connected?</li> <li>② Are the rise and fall pipes correctly connected?</li> <li>③ Are the lengths and height differences of the pipes within the recommended limits?</li> </ol>
Operational control	<ol style="list-style-type: none"> <li>① Are the interconnections between the piping and wiring of the indoor and outdoor units clearly shown?</li> <li>② Are the numbers of the local setting switches clearly shown? (Group No. and Unit No.)</li> <li>③ Are the wiring connections between the remote controller and the centralized and remote controls clearly shown? <b>Refer to the notes relating to the preparation of the control wiring system diagrams (see next page)</b></li> <li>④ Are the different types of wires clearly marked?</li> <li>⑤ Are there any problems with the way the power supply cables and control wiring have been separated or bound together?</li> <li>⑥ Are the inter-floor connections of the control wiring correct?</li> <li>⑦ Is the position of the remote controller clearly marked?</li> </ol>
Miscellaneous	<ol style="list-style-type: none"> <li>① Have you checked the gradient of the drain piping? (Must be at least 1/100)</li> </ol>

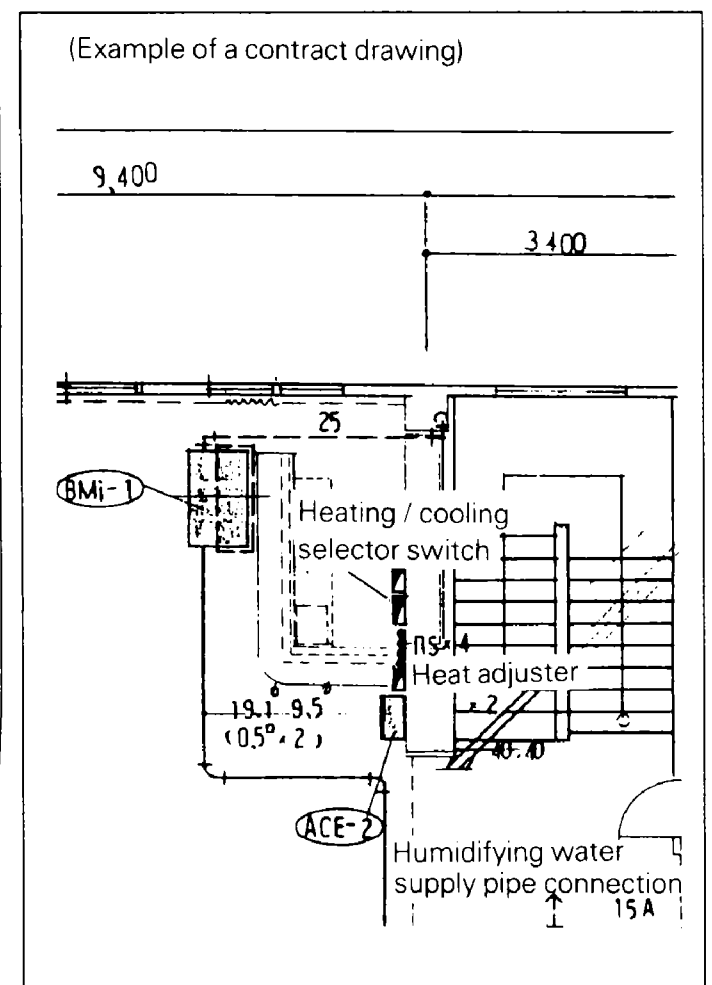

## (2) Main considerations in preparation of control circuit diagrams

In addition to the design of the appropriate this system configuration it is also essential that the control system be made amply clear. If the system is designed and installed without a clear, comprehensive plan then problems are inevitably going to occur during the test run.

Servicing too will become much more time consuming than necessary. However, if control circuit diagrams are prepared along with the contract drawings in order to make the total system clearly visible then the essential points relating to the electrical connections will be easily understood, the test run will go off without a hitch and the whole system will be rendered fully effective.

## Step 1: Compiling a system parts list (example using Inverter K Series)

- ① Mark each outdoor unit with a code.
- ② Add field settings and data for outdoor units, and outdoor unit No. if using sequential start.
- ③ Add the model number of each indoor unit connected to each refrigerant circuit.
- ④ Assign each indoor unit a code.
- ⑤ Fill in the location of each indoor unit.
- ⑥ Group indoor units controlled by one or two remote controllers. (group or individual control).
- ⑦ Assign central group Nos. if using centralized control.
- ⑧ Add field settings and optional equipment for indoor units.
- ⑨ Add unit No. if making separate field settings for each indoor unit under group control.

NOTE: With the Inverter K Series, unit No. is determined through automatic addressing, therefore readout unit Nos. after activating the power.

Example: System parts list

Outdoor unit		Indoor unit						
Model name (code)	Field settings	Model name	System name	Location	Remote controller group	Centralized control group No.	Unit No.	Optional equipment, field settings, etc.
RSXY10K (PAC1)	Cool/Heat selector: Indoor unit Low noise operation (L.N.O.P): Individual control Sequential start: ON Defrost: Earlier Sequential start No.	FXYC32K	2F01	2nd floor office	A	1-00		
		FXYC63K	2F02	2nd floor office	A	(1-00)		
		FXYC40K	2F03	2nd floor office	A	(1-00)		
		FXYC63K	2F04	2nd floor office	B	1-01		
		FXYC50K	2F05	2nd floor office	B	(1-01)		
RSXY10K (PAC2)	Cool/Heat selector: Indoor unit Low noise operation (L.N.O.P): Individual control Sequential start: ON Defrost: Earlier	FXYC32K	3F01	3rd floor office	C	1-02		
		FXYC40K	3F02	3rd floor office	C	(1-02)		
		FXYC50K	3F03	3rd floor office	C	(1-02)		
		FXYC50K	3F04	3rd floor office	D	1-03		

For details on field settings and centralized control group No., refer to the installation manual and system reference materials.

## Step 2: Preparation of the control circuit diagrams

The following sequence should be followed in order to prepare control circuit diagrams in accordance with the parts list which has already been completed:

- ① Diagrams should be prepared for each individual outdoor unit. The outdoor unit model number should be inserted into the diagram.  
(RSXY10K)
- ② Insert name of refrigerant system. (PAC1, PAC2)
- ③ Insert name of indoor unit.  
(FXYC32K→C32K)

- ④ Insert system name of indoor unit.
- ⑤ Insert installation position. (Do this when demarcation is possible)
- ⑥ Insert remote controller control wiring. (Group)  
Indicated by solid line. ....Solid line.
- ⑦ Insert centralized control wiring. ....Dotted line
- ⑧ Insert Group No. (GNo. for each indoor unit with UNo. 0)

The control circuit diagrams are now complete.

Example: Control circuit diagram

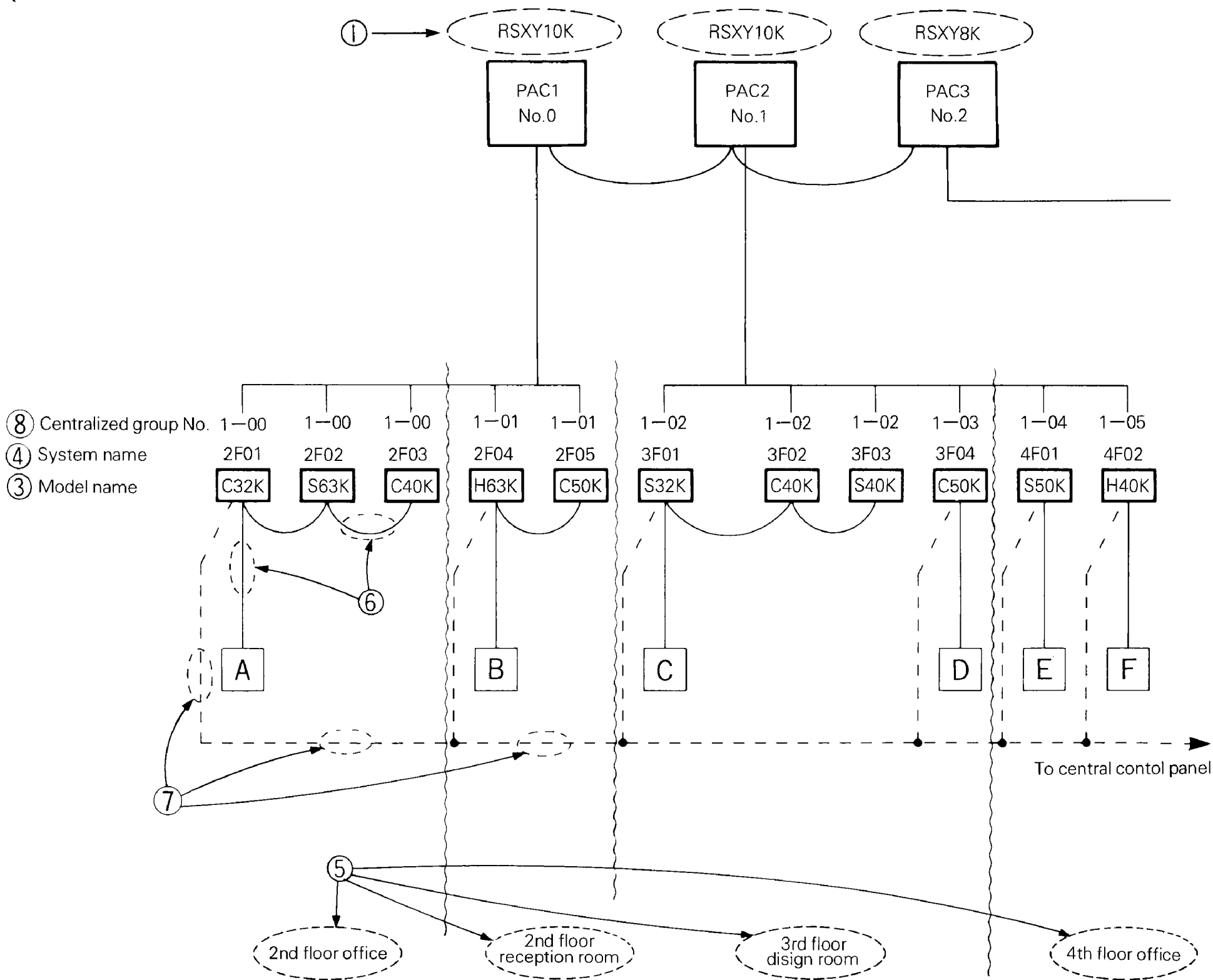

## 2. Installation

### 2.1. Step by step installation procedure

	<Operations>	<Points>
Prework	Determination of division of work	Indicate clearly who is to be responsible for switch settings
	Preparation of contract drawings	Make relationship between outdoor, indoor, remote controller and option connections clear. (Prepare control circuit diagrams)
Work	Sleeve and insert work	Take account of gradient of drain piping
	Installation of indoor unit	Check model name to make sure the fitting is made correctly
	Refrigerant piping work	Special attention to dryness, cleanness and tightness
	Drain pipe work	Adjust to downward gradient
	Duct work	Make sure airflow is sufficient.
	Heat insulation work	Make sure no gaps are left where the insulating materials are joined
	Electrical work (connection circuits and drive circuits)	Multiple core cable must not be used. (Suitable cable should be selected)
	Setting of indoor unit setting switches	Must be carried out in strict accordance with control circuit diagrams
	Outdoor unit foundation work	The foundation must be level
	Installation of outdoor unit	Avoid short circuits and ensure sufficient space is allowed for servicing
	Setting of outdoor unit setting switch	Must be carried out in strict accordance with control circuit diagrams (Sequence start, low noise input, Cooling/Heating selection refrigerant piping length etc.)
	Air tight test	In the final check for 24 hours at 28.0 kg/cm <sup>2</sup> there must be no drop in pressure
	Vacuum drying	The vacuum pump used must have a capacity of reaching at least 5 mmHg
	Additional charge of refrigerant	Make sure there are no gaps left between the facing materials used on the ceiling
	Fit facing panels	Make sure there are no gaps left between the facing materials used on the ceiling
	Test run adjustment	Run each indoor unit in turn to make sure the pipework has been fitted correctly
	Transfer to customer with explanation	Explain the use of the system as clearly as possible to your customer and make sure all relevant documentation is in order

The above list indicates the order in which the individual work operations are normally carried out but this order may be varied where local conditions warrant such a change

## 2.2. Work involved in individual operations and points to be borne in mind

### (1) Sleeve and insert work

#### ● Operational steps

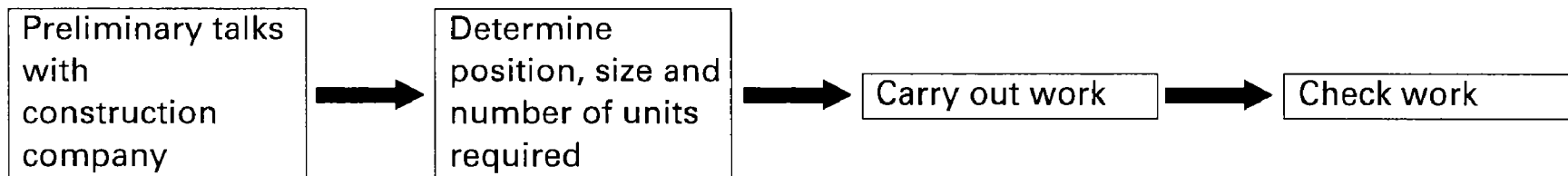

#### 1) Positioning of the pipe holes

- The through holes for the drain piping should be positioned such that the pipes have a downward gradient. (The gradient must be at least 1/100. The thickness of the insulating materials must also be taken into consideration.)
- The diameter of the through holes for the refrigerant piping should include an allowance for the thickness of the heat insulation materials. (It is a good idea to think of the liquid and gas pipes as pairs.)
- Attention should be paid to the construction of the beam themselves since there are sometimes parts of the beam which cannot be used to accommodate through holes.

**Example:** Through holes in a reinforced concrete beam

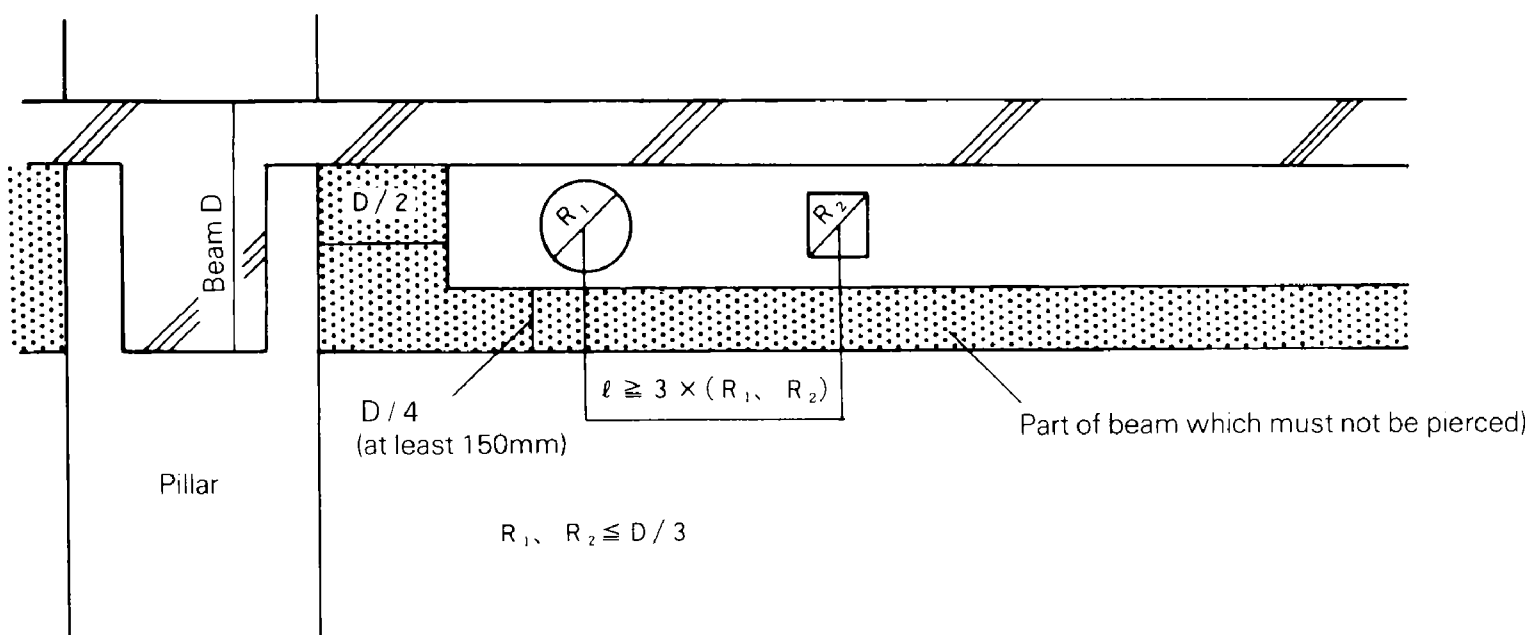

#### 2) Positioning the insert

- An insert is a metal tool which is inserted into a floor or a beam before the concrete is set such that fittings such as ducts, pipes or suspension bolts for hanging units can be fitted into place later. The positions of the inserts must be decided early.

**Example:** Steel insert

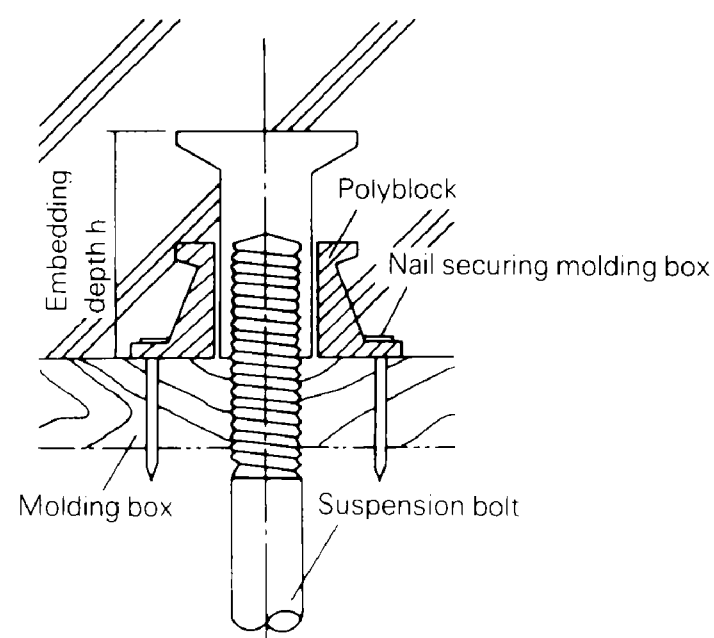

#### Important point:

- The weight of the fitting to be suspended must be taken into account when choosing the insert.

## (2) Installation of indoor unit

### ● Operational steps

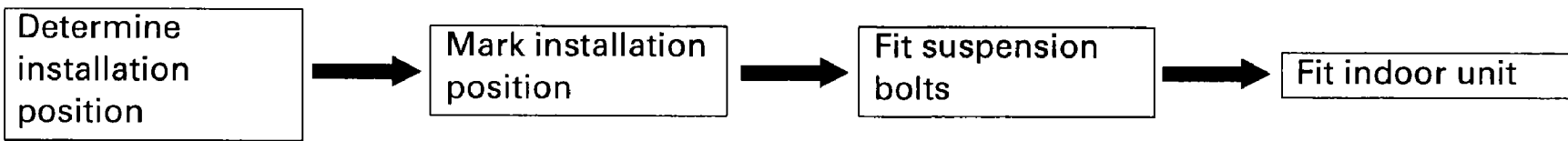

### 1) Positioning

#### 3 essential points when installing an indoor unit

- ① Height: Take care to account for final ceiling facing surface level
- ② Level: Level fitting is essential. (within  $\pm 1$  degree of horizontal)
- ③ Direction: The unit must be fitted in line with the ultimately visible ceiling joints

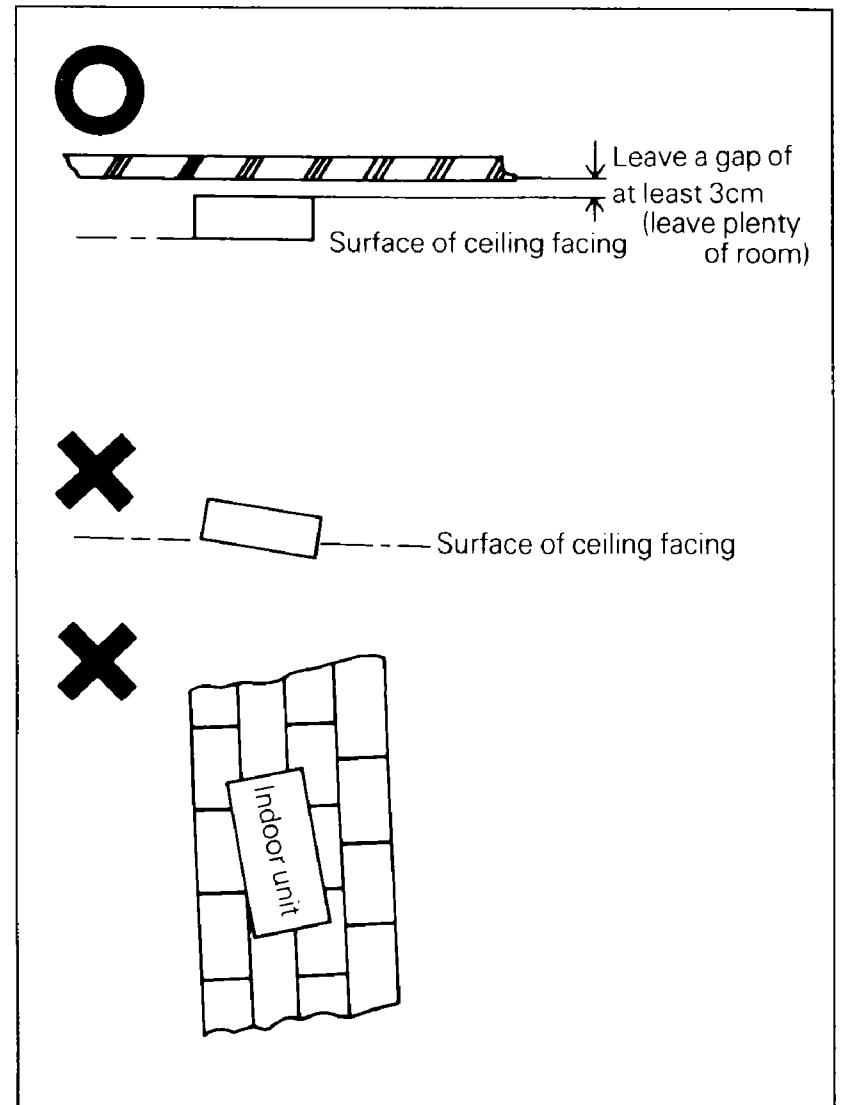

### Important points

- ① The suspension bolts must be strong enough to support the weight of the indoor unit.
- ② Optional features must be added to the indoor unit prior to installation.
- ③ The model name should be checked prior to installation.
- ④ Take care to align the main unit correctly. (Bearing in mind piping layout and direction of blow out)
- ⑤ Leave sufficient space for servicing to be carried out.
- ⑥ Make inspection holes for model which need them.
- ⑦ Fit the unit to ensure proper drainage.

Example: Ceiling mounted cassette type (FXYC63)

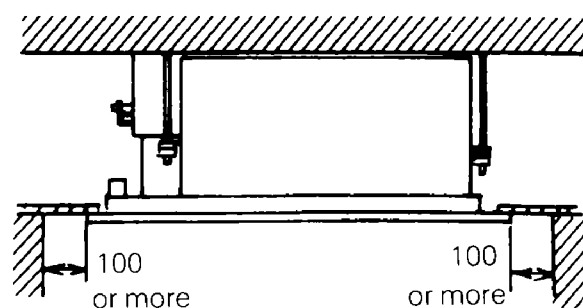
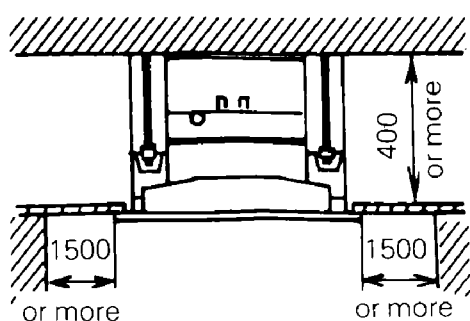



### (3) Refrigerant pipe work

#### • Operational steps

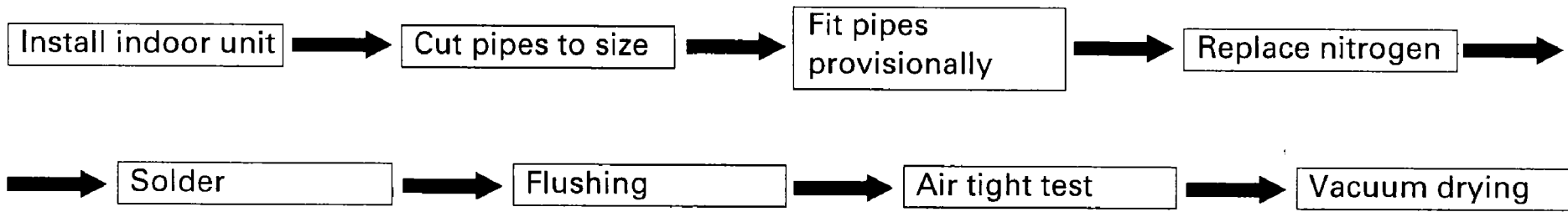

#### 1) The 3 principles of refrigerant piping

The "3 principles of refrigerant piping" must be strictly observed

	Cause of problem	Actoin to avoid problem
Dry	<ul style="list-style-type: none"> <li>• Rainwater, work water, etc. gets into pipes from outside</li> <li>• Moisture generated inside pipes due to condensation</li> </ul>	Pipe covering → Flushing → Vacuum drying See page 43
Clean	<ul style="list-style-type: none"> <li>• Formation of oxides inside pipes during soldering</li> <li>• Dirt, dust or other extraneous material gets into pipes from outside</li> </ul>	Replace nitrogen → Flushing Pipe covering → Flushing
Air tight	<ul style="list-style-type: none"> <li>• Leak from soldered area</li> <li>• Leak from flared area</li> <li>• Leak from flange area</li> </ul>	Use the proper materials (copper pipe, solder, etc.) Adhere strictly to standard soldering work practice Adhere strictly to standard flaring work practice Adhere strictly to standard flange connection work parctice Air tight test See page 41

#### The 3 principles of refrigerant piping

Dry	Clean	Air tight
Make sure there is no moisture inside the pipes	Make sure there is no dirt inside the pipe	Make sure the refrigerant does not leak out

## 2) Method for replacing nitrogen (soldering)

If soldering work is carried out without passing nitrogen gas through the pipes which are being soldered then this allows the formation of oxidation bubbles on the inside surface of the pipes. These oxidation bubbles are then carried along inside the pipes to cause damage to various members of the system such as valves or compressors and the system ceases to function properly.

In order to avoid this problem nitrogen is passed through the pipes while the soldering work is being carried out. This operation is known as nitrogen replacement. (Air is replaced by nitrogen)

This is standard work practice for all soldering work.

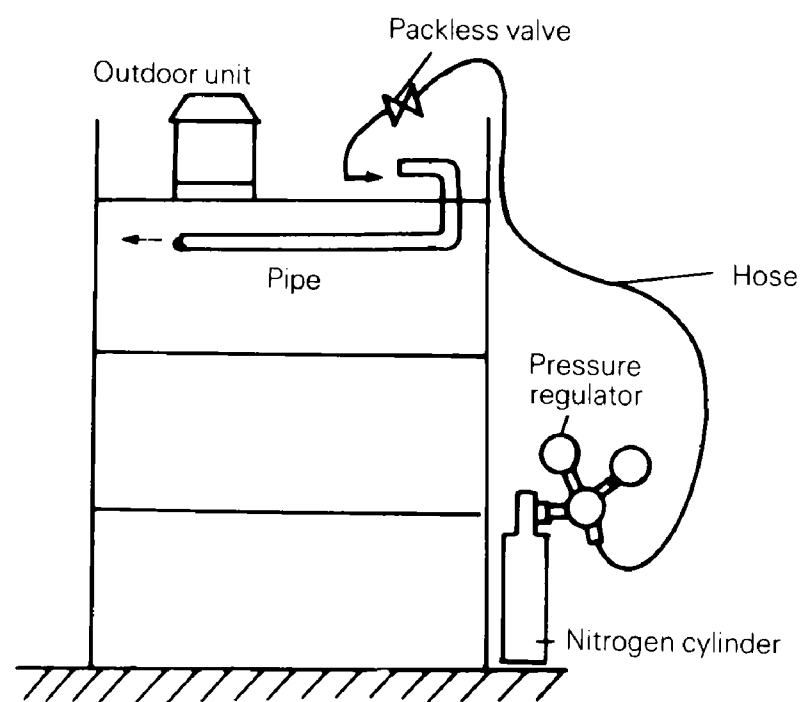
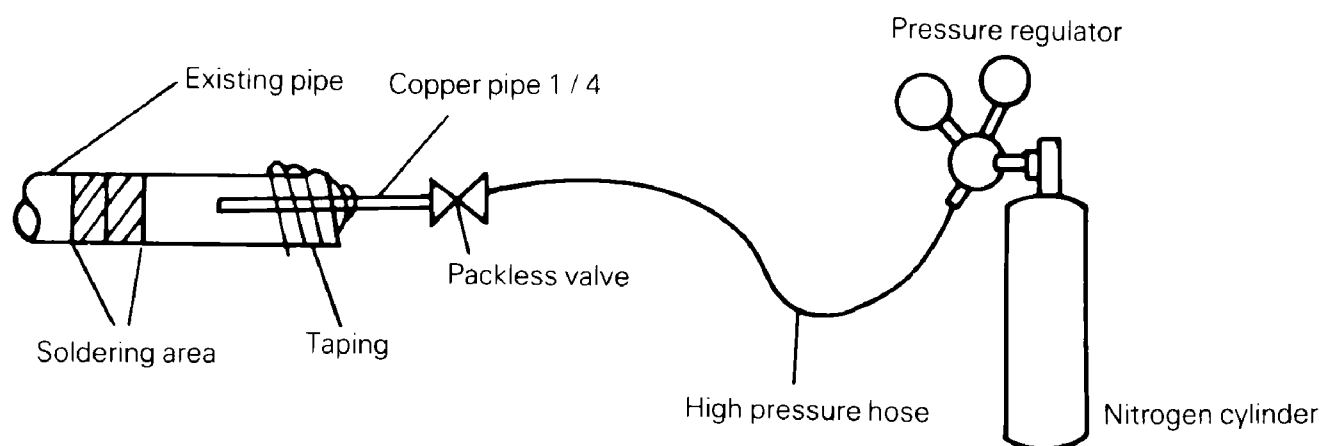

### Important points:

- ① The gas used must be nitrogen (oxygen, carbon dioxide and flon gas are inappropriate)
- ② A pressure regulator must be used.

### 3) Covering of refrigerant pipes

Covering is an extremely important operation as it prevents water, dirt or dust from getting inside the pipes. Moisture inside the pipes was a constant source of trouble in the past. The utmost care is required to nip this problem in the bud.

The end of each pieces of pipe must be covered. "Pinching" is the most effective method but "taping" is an simple alternative which may be used according to the work area and term of work.

Location	Term of work	Covering method
Outdoors	3 months or more	Pinching
	Less than 3 months	Pinching or taping
Indoors	Irrelevant	Pinching or taping

① Pinching method

The end of the copper pipe is squeezed together and the gap soldered.

② Taping method

The end of the copper pipe is covered with PVC tape.

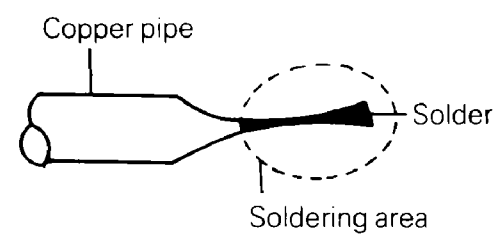

<Taping method>

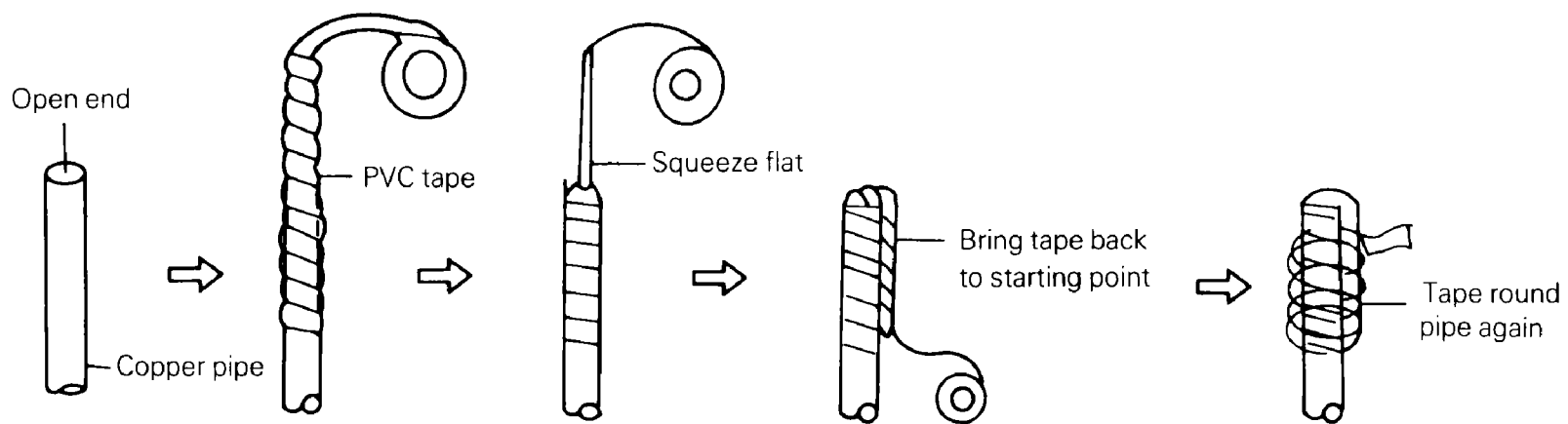

Particular care should be taken during the following operations:

- When passing copper pipe through a through hole (Dirt easily gets into the pipe).
- When copper pipe is pushed through to outside (Rainwater gets in )  
(Special care is needed when the pipes are standing vertically outside)

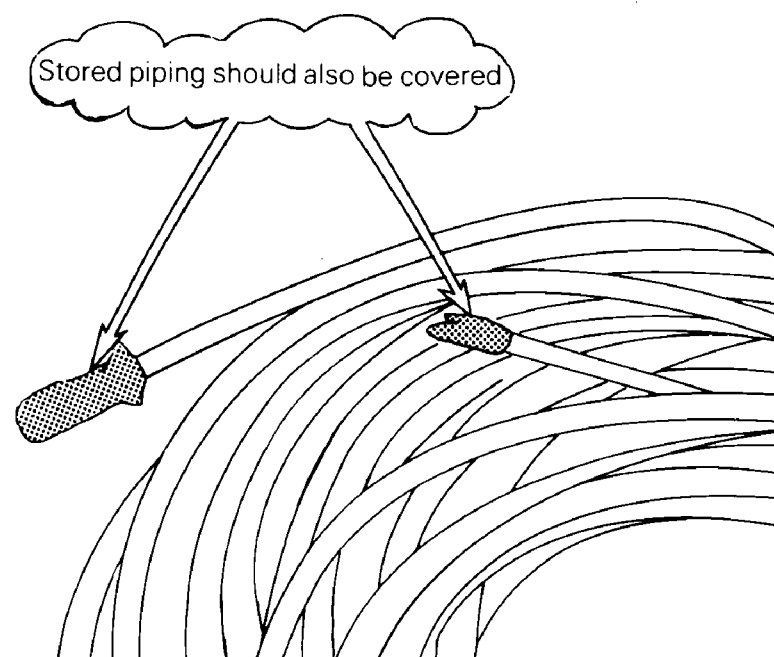
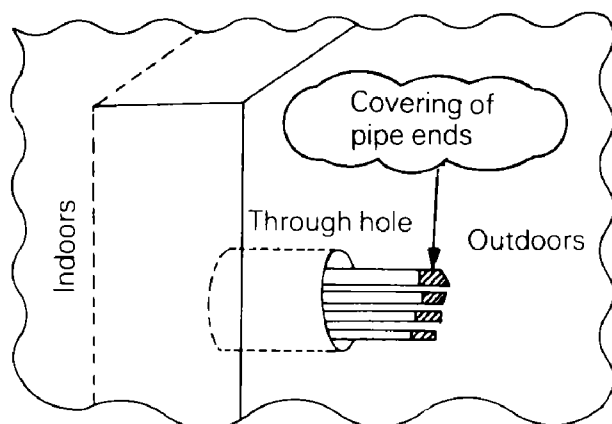

#### 4) Refrigerant pipe flushing

Flushing is a method of cleaning extraneous matter out of pipes using pressurized gas.

[3 major effects]

- ① Removal of oxidation bubbles formed inside copper pipes when "nitrogen replacement is insufficient" during soldering work
- ② Removal of extraneous material and moisture from pipes when covering has been insufficient
- ③ Checks connections in pipes linking outdoor and indoor units (Both liquid and gas pipes)

[Example of procedure]

- ① Set pressure regulator on nitrogen cylinder.
  - ※The gas used must be nitrogen.
  - (There is a danger of condensation if fluoron or carbon dioxide are used and oxygen carries the risk of explosions.)
- ② Connect the charge hose from the pressure regulator to the service port on the liquid pipe side of the outdoor unit.
- ③ Fit blanking plugs to all indoor units (B) other than unit A.
- ④ Open the main valve on the nitrogen cylinder and set the pressure regulator to 5 kg/cm<sup>2</sup>.

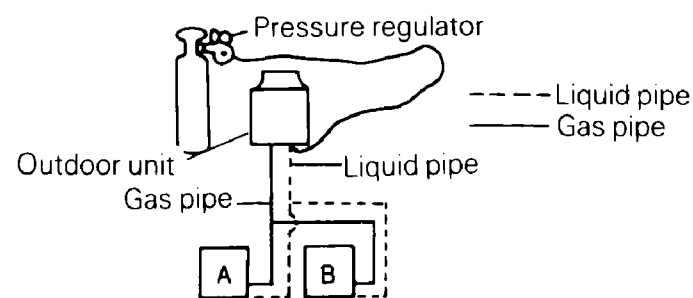

- ⑤ Check that the nitrogen is passing through the unit A liquid pipe.

#### ⑥ Flushing.

- Block the end of the pipe with the insulation of your hand.
- ↓
- When the gas pressure becomes too great to contain remove insulation quickly. (First flush)
- ↓
- Block the end of the pipe with insulation again.
- ↓
- (Carry out second flush)

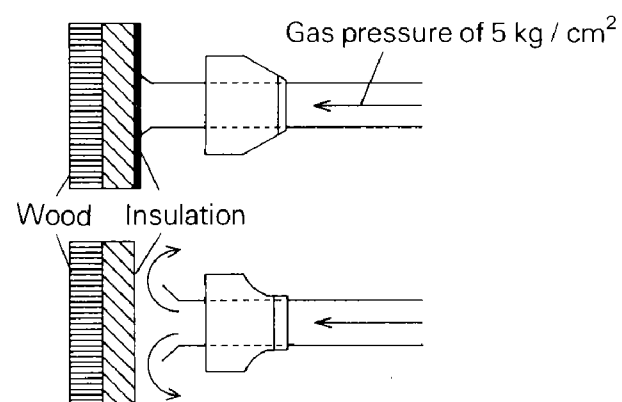
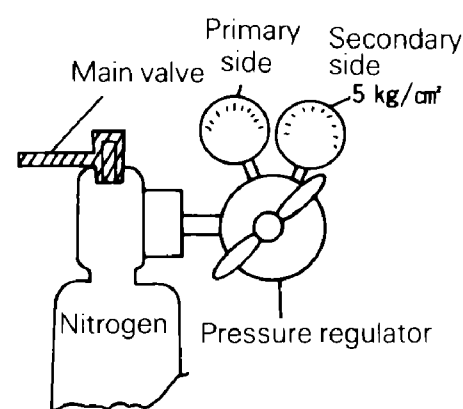
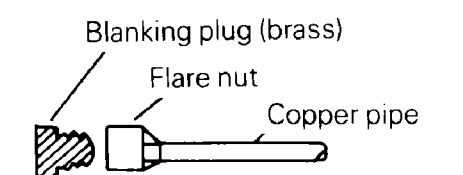

(The nature and amount of the extraneous material inside the pipe can be checked during flushing by placing a rag lightly over the end of the pipe. In the unlikely case that even a small quantity of moisture is found then the inside of the pipe should be dried out thoroughly.)

Action:

- (1) Flush the inside of the pipe with nitrogen gas.
  - (Until such time as the moisture disappears.)
- (2) Carry out a thorough vacuum drying operation. (See page 43)
  - ① Close the main valve on the nitrogen cylinder.
  - ② Repeat the above operation for unit B.
  - ③ When the liquid pipe operations have been completed then do the same with the gas pipes.

## 5) Choice of materials for refrigerant piping









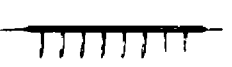

### a) Refrigerant piping

- The piping used must meet the requirements of the JIS standard. (Size, material, thickness, etc.)  
Specification: Oxidized phosphorous seamless copper pipe
- Long pipe lengths or coiled pipe (copper pipe with heat insulation coating) should be used to avoid the necessity for frequent soldering.
- The whole job is made easier if rolled copper pipe with a heat insulation coating is used.

### b) Soldered joints and special branches

- ① General use (L bend joint, socket joint, T joint, etc.)
  - Joints must meet the requirements of the relevant JIS standard. (Size, materials, thickness, etc.)
- ② Special branches
  - The Daikin product specified for each series (model) should be used.

### Example: INVERTER SERIES

		REFNET header			
REFNET joint		For outdoor unit RSXY5K (5HP)		For outdoor unit RSXY8K/10K (8HP/10HP)	
		4 branches	8 branches	6 branches	8 branches
Liquid pipe (with heat insulation coating)					
Gas pipe (with heat insulation coating)					

### c) Soldering

The Multi-System requires only copper/copper jointing and the jointing method is explained below.

- The use of "hard solder is essential.

Type	Solder: JIS mark	Soldering temperature (°C)	Breaking strength (kg/mm <sup>2</sup> )	Soldering method	Jointing distance (mm)	Example for reference (product name)	Flux (example for reference)	Remarks
Hard solder	BCup-2 (Phosphor copper solder)	735 ∪ 840	Approx. 25	0.05 ∪ 0.2	Gas	NEiS # 2BD	Not required	BCup reacts easily with sulfur to form a fragile water-soluble compound and should not therefore be used where the environment is not suitable.
	BAG-2 (Silver solder)	700 ∪ 845	Approx. 20	0.05 ∪ 0.2	Gas	NEiS # 107	NEiS # 103	Suitable for environments with a high sulfur content

↓  
This is used under normal conditions.

## 6) Soldering

- a) Soldering work should be carried out such that the final result is directed either downwards or sideways. An upward direction should be avoided wherever possible. (to prevent leakage)

< Recommended method >

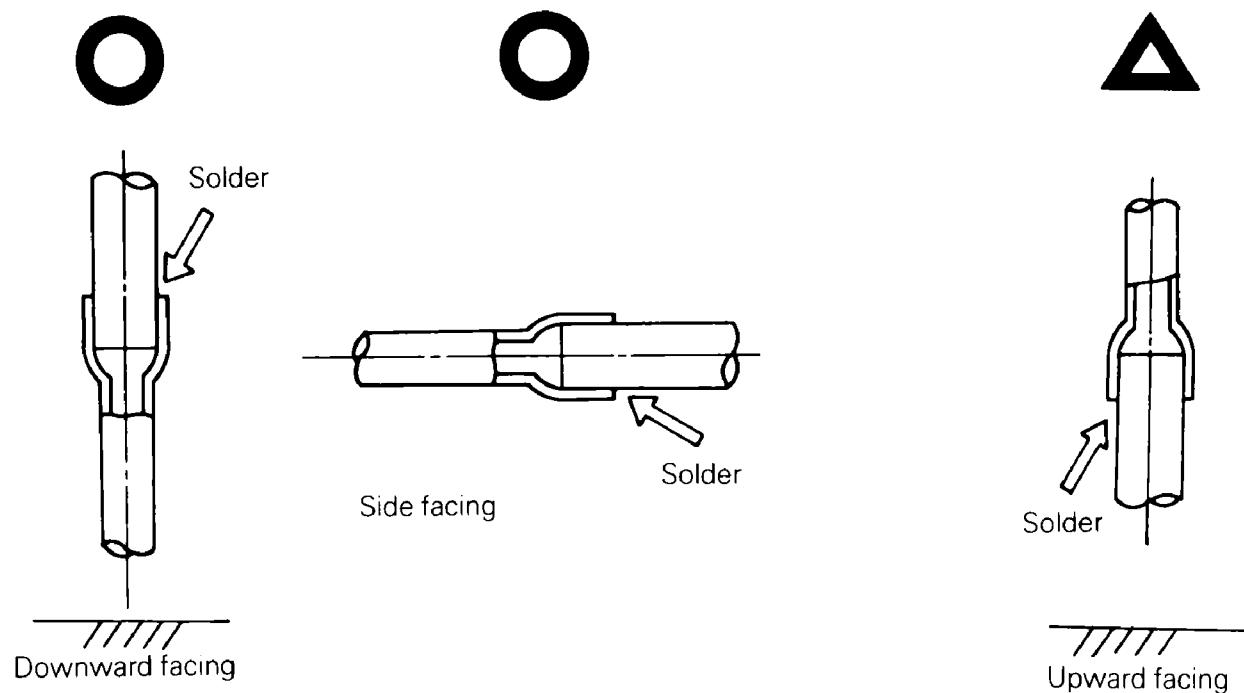

- b) Liquid and gas pipe branches should always be dealt with in the specified way with attention being paid to the direction of the fitting and its angle. (to prevent oil return or drift) For example see page 66.  
 c) It is standard working practice to use the nitrogen replacement method when soldering.

### Important points

- ① Every effort must be made to avoid fire. (Clean area where soldering is to be performed and make sure that fire fighting equipment and water are ready to hand.)
- ② Be careful of burns.
- ③ Make sure that the gap between the pipe and the joint is correct. (To prevent leaks)
- ④ Is the pipe adequately supported?
  - As a rule the gaps between supports for horizontal piping (copper pipe) are as follows:

Copper pipe support spacing (From HASS 107-1977)

Nominal diameter	20 or less	25~40	50
Maximum gap (m)	1.0	1.5	2.0

- The copper pipe should not be secured directly by metal brackets.

## 7) Flare connection

- (a) Stiffened pipe must always be annealed at least once prior to the flaring work.
- (b) A pipe cutter must be used to cut the pipe. (A large pipe cutter must be used where the pipe has a large diameter. When cutting a pipe which is too big for the pipe cutter a metal saw may be used but care must be taken to ensure that the debris from sawing does not get into the pipe.)
- (c) Set the flaring tool to make sure the flare size remains within the prescribed limits.

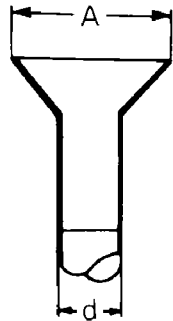

Nominal diameter	External diameter of pipe d	Pipe widening dimensions A
3/8 <sup>B</sup>	9.53	12.2~12.8
1/2 <sup>B</sup>	12.7	15.6~16.2
5/8 <sup>B</sup>	15.88	18.8~19.4
3/4 <sup>B</sup>	19.05	23.1~23.7

- (d) Coat the inner and outer surface of the flare with refrigerator oil. (this ensures that the flare nut passes smoothly, preventing the pipe from twisting.)

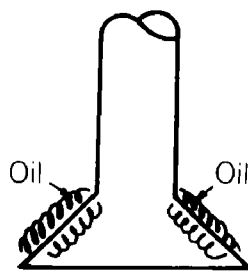

### Important points

- ① Burrs should be carefully removed.
- ② 2 spanners should be used to grip the pipe.
- ③ The flare nut must be inserted before starting the flaring operation.
- ④ The appropriate amount of torque should be used to tighten the flare nut.

Standard torques for tightening flare nut  $\pm 10\%$

Size	Torque	
	(kgf-cm)	(N-cm)
1/4(6.4 $\phi$ )	144~176	1420~1720
3/8(9.5 $\phi$ )	333~407	3270~3990
1/2(12.7 $\phi$ )	504~616	4950~6030
5/8(15.9 $\phi$ )	630~770	6180~7540
3/4(19.1 $\phi$ )	990~1210	9270~11860

- ⑤ Check that there is no superficial damage to the surface of the flare.

**8) Flange connection**

- a) The flange sheet surface should be clean and undamaged. (Clean any dirt away with a cloth and check that there has been no damage.)
- b) Coat the flange sheet surface with refrigeration oil and then insert the packing.

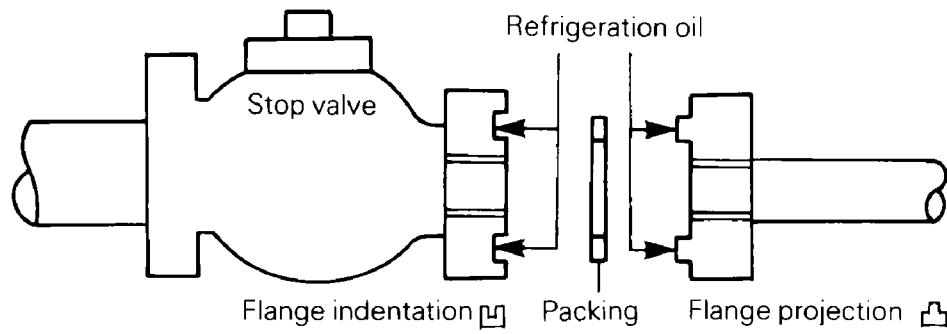

- c) Tighten the bolts in opposite corners first to ensure that the connection is true.

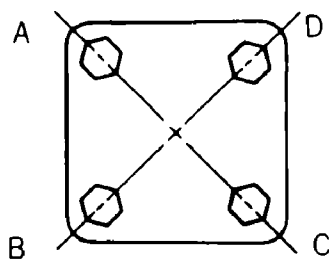

[Example]  
Order: A → B → C → D

The bolts should be tightened little by little in the above order such that the same degree of torque is applied evenly to each corner.

**Important points**

- ① Only clean refrigeration/oil should be used to coat the flange. (i.e. free from dirt or water)
- ② The correct amount of torque should be applied when tightening the flange bolts.

Standard torques for tightening screws and bolts

ISO hexagonal bolt

Size \ Class	5.8(5T)		10.9(10T)	
	kgf-cm ±15%	N-m ±15%	kgf-cm ±15%	N-m ±15%
M8	125	1230	302	2960
M10	257	2520	620	6080
M12	436	4280	1,050	10,300
M16	1,030	10,100	2,480	24,300
M20	2,050	20,100	4,950	48,500



#### (4) Drain pipe work (indoor)

- **Operational steps**

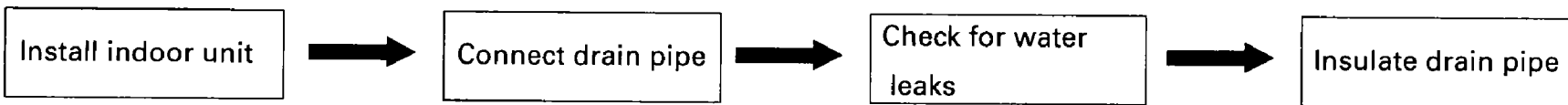

#### 1) Drain pipe gradient and support

- a) ● The drain pipe must be fitted at a gradient of at least 1/100.  
 ● The drain pipe should be as short as possible and free from airlocks.

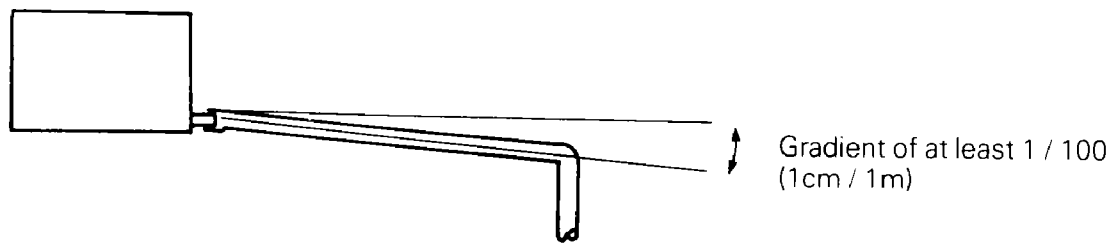

- b) Suspension bolts should be used to support long stretches of drain pipe in order to ensure that a gradient of 1/100 is maintained. (PVC pipes should not be bent)

#### Spacing of supports for horizontal piping

Class	Nominal diameter	Spacing
Rigid PVC pipe	25~40mm	1~1.5m

- c) The length of pipe laid horizontally should be kept to a minimum.

#### 2) Drain trap

Fit any indoor unit whose drain pipe connection is subjected to negative pressure, with a drain trap.

- a) Rig the drain trap as shown in the drawing bellow.

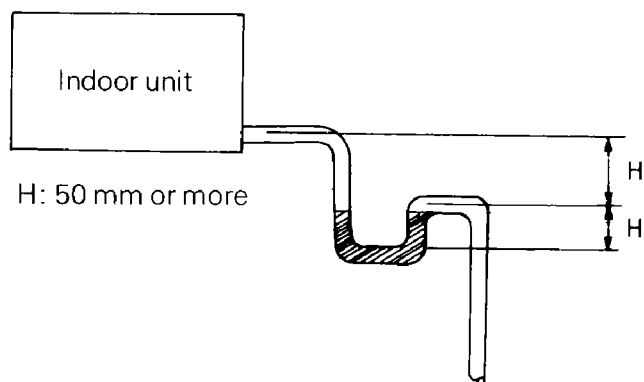

- b) Provide one trap per unit. A single trap for converging units will prove ineffective.

- c) Rig the trap to allow for future cleaning.

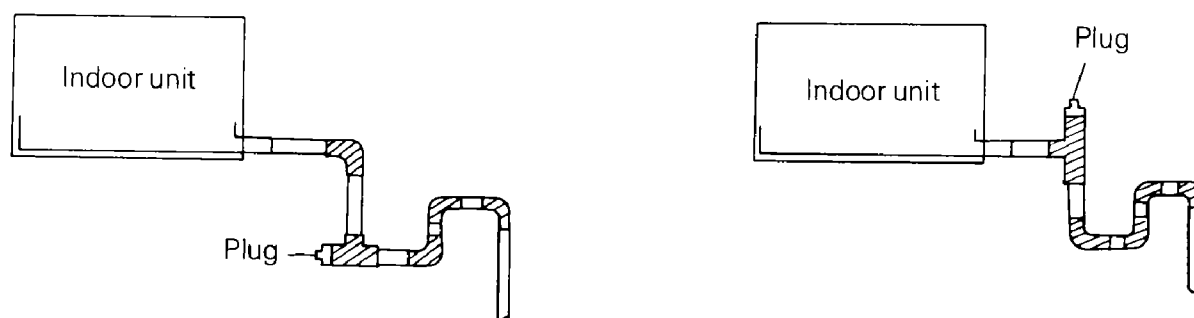

### 3) Grouped drain piping

- ① It is standard work practice to make connections to the main pipe from above. The pipe down from the combination should be as large as possible.

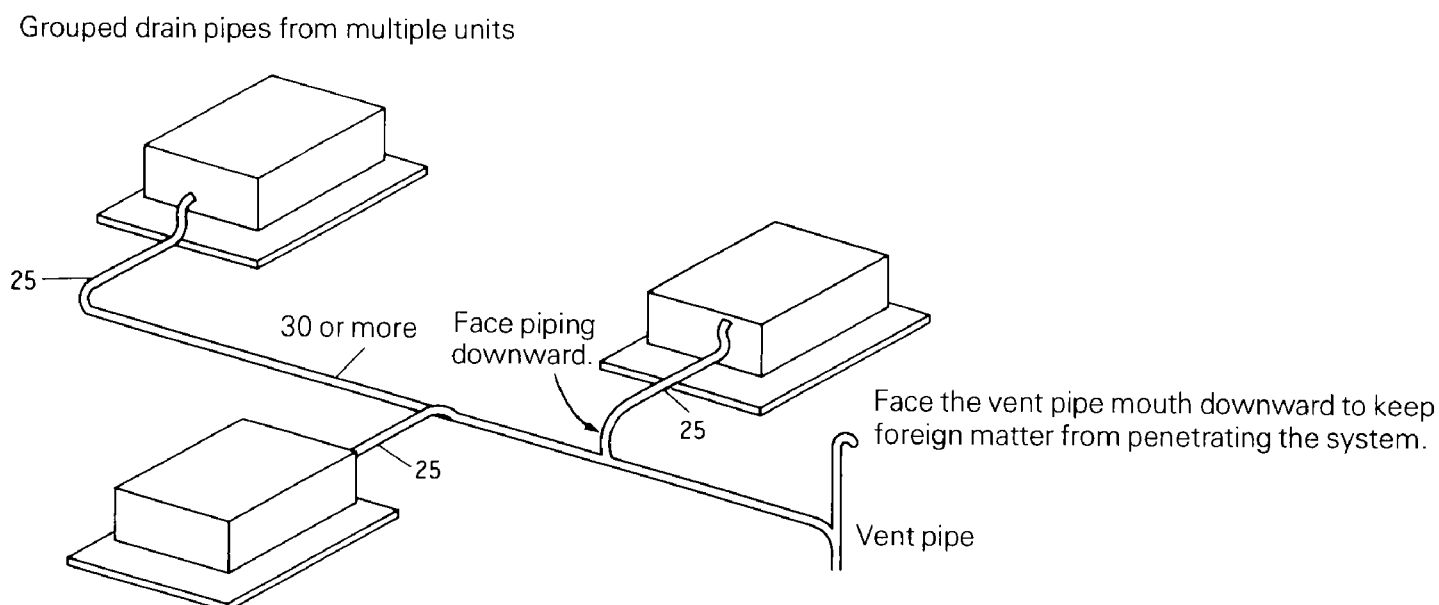

- ② The pipework should be kept as short as possible and the number of indoor units per group kept to a minimum.

### 4) Use of an auxiliary drain hose (flexible)

If a drain pan made of polystyrene foam is used then an auxiliary drain hose (flexible) is also essential. A flexible drain hose permits the drain socket and drain pipe to be connected without difficulty and prevents any undue strain being placed on the drain pan.

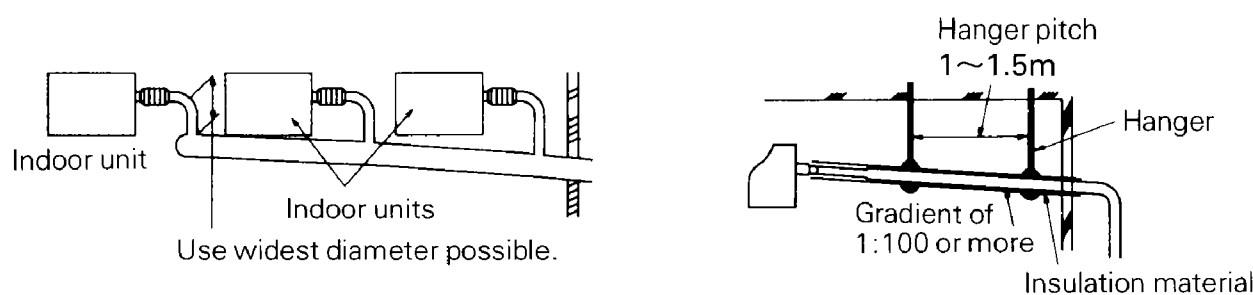
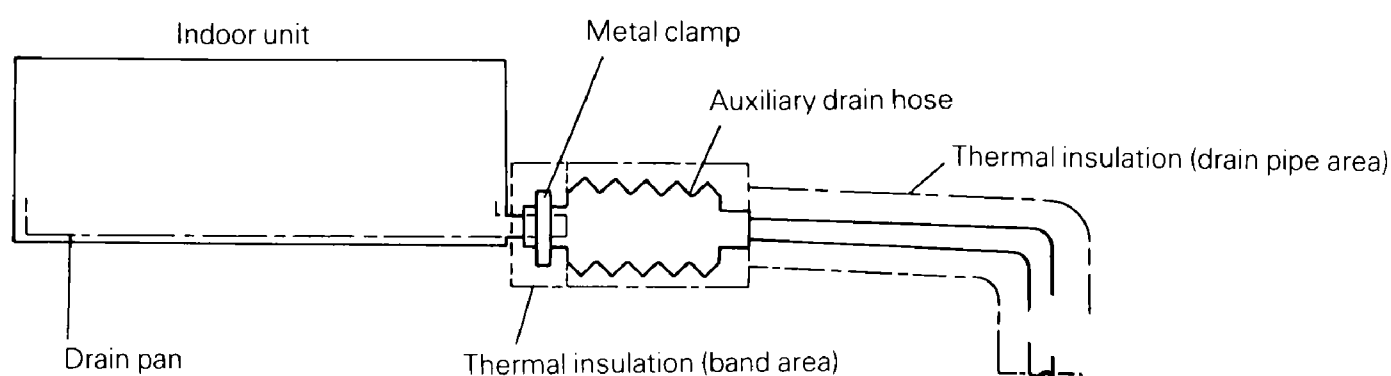

### Important points

- ① The drain pipe should be at least equal in size to that of the indoor unit.
- ② The drain pipe is thermally insulated to prevent the formation of condensation inside the pipe.
- ③ The drain up mechanism should be fitted before the indoor unit is installed and when the electricity has been connected some water should be added to the drain pan and the drain pump checked to see that it is functioning correctly.
- ④ All connections should be secure. (Special care is needed with PVC pipe)  
The use of a colored adhesive with PVC pipes will help you to remember to connect them up.)

### 5) Piping diameter for grouped drain pipes

- Select piping diameter from the below table in accordance with the amount of condensation drained by all units with a common drain pipe.
- Consider 2 l/hr of drainage for every 1 HP. For example, drainage from 3 units running at 2 HP and 2 units running at 3 HP is calculated as follows.

$$2 \text{ (l/hr)} \times 2 \text{ (HP)} \times 3 \text{ (units)} + \{ 2 \text{ (l/hr)} \times 3 \text{ (HP)} \times 2 \text{ (units)} = 24 \text{ l/hr}$$

#### ① Relationship between horizontal pipe diameter and allowable drainage (for extended ventilation system)

JIS nominal	Vinyl chloride pipe diameter (mm)	Allowable flow rate (l/hr)		Remarks
		Piping gradient 1:50	Piping gradient 1:100	
VP20	20	39	27	(Reference value) Cannot be used in grouped piping.
VP25	25	70	50	
VP30	31	125	88	Can be used in grouped piping.
VP40	40	247	175	
VP50	51	473	334	

- NOTE ● Calculations have been made with water area inside the pipe as 10%.  
 ● Allowable flow rate figures below the decimal have been discarded.  
 ● Use VP30 or larger pipe after the convergence point.

#### ② ① Relationship between riser diameter and allowable drainage (for extended ventilation system)

JIS nominal	Vinyl chloride pipe diameter (mm)	Allowable flow rate (l/hr)	Remarks
VP20	20		(Reference value) Cannot be used in grouped piping.
VP25	25	220	
VP30	31	410	Can be used in grouped piping.
VP40	40	730	
VP50	51	1440	
VP65	67	2760	
VP75	77	5710	

- NOTE ● Allowed flow rate figures below the decimal have been discarded.  
 ● Use VP30 or larger pipe in risers.  
 ● Use the same drain pipe for the humidifier as the indoor unit.

## ■ Drain piping

### 1. Ceiling mounted cassette type (FXYC Double flow)

#### (1) Rig drain piping

- The diameter of the drain pipe should be greater than or equal to the diameter of the connecting pipe (vinyl tube; pipe size: 25mm; outer dimension: 32mm).
- Keep the drain pipe short and sloping downwards at a gradient of at least 1/100 to prevent air pockets from forming.
- If the drain hose cannot be sufficiently set on a slope, execute the drain-raising piping.
- To keep the drain hose from sagging, space hanging wires every 1 to 1.5 m.

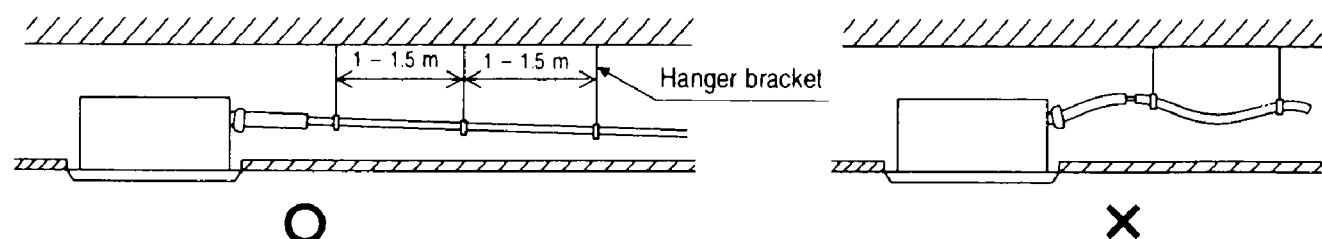

- Use the attached drain hose and clamp metal.
- Insert the drain hose into the drain socket, up to the white tape. Tighten the clamp until the screw head is less than 4 mm from the hose.
- Wrap the attached sealing pad over the clamp and drain hose to insulate.
- Insulate the drain hose inside the building.

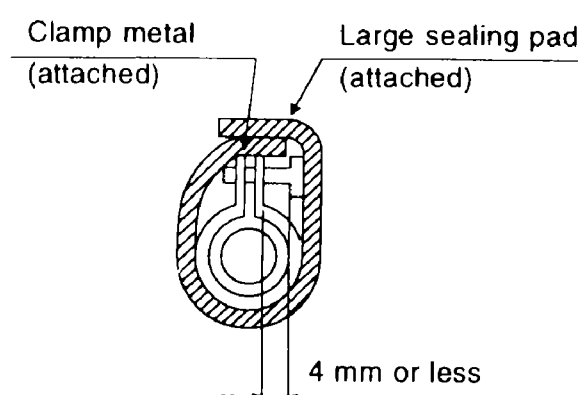
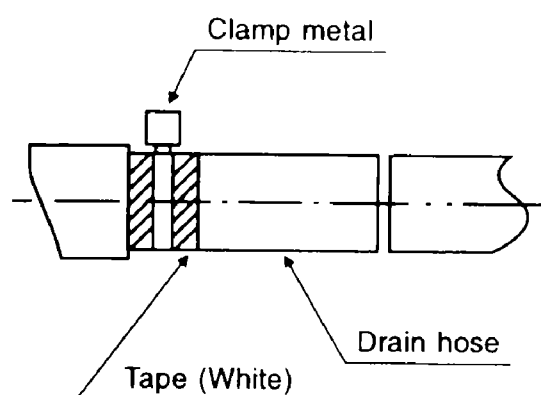

#### (PRECAUTIONS FOR DRAIN RAISING PIPING)

- Install the drain raising pipes at a height of less than 310 mm.
- Install the drain raising pipes at a right angle to the indoor unit and no more than 300 mm from the unit.

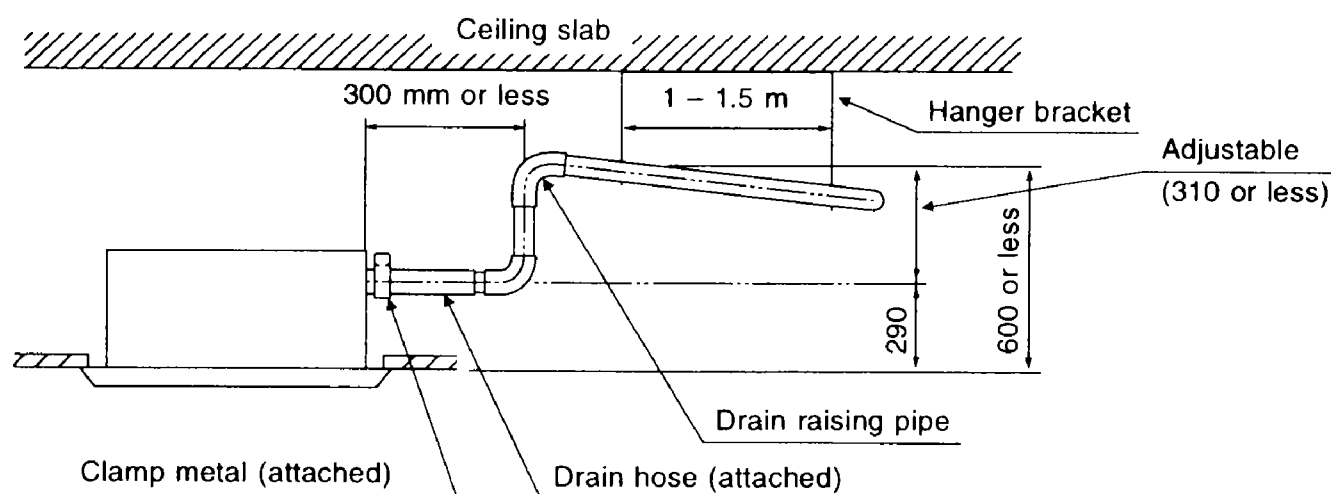

- If converging multiple drain pipes, install according to the procedure shown below.

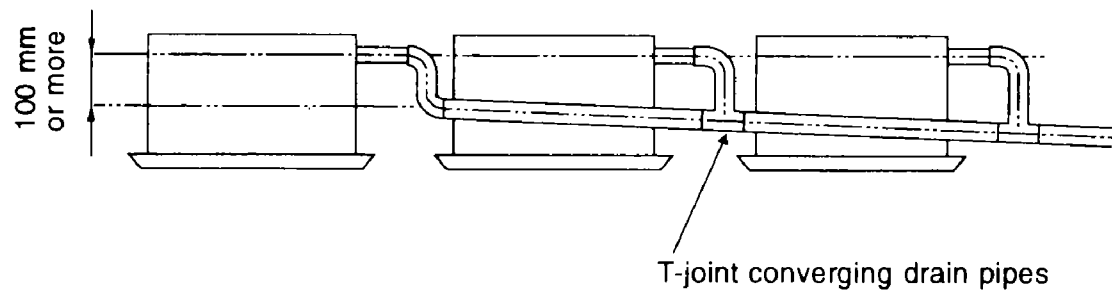

Select converging drain pipes whose gauge is suitable for the operating capacity of the unit.

(2) After piping work is finished, check drainage flows smoothly.



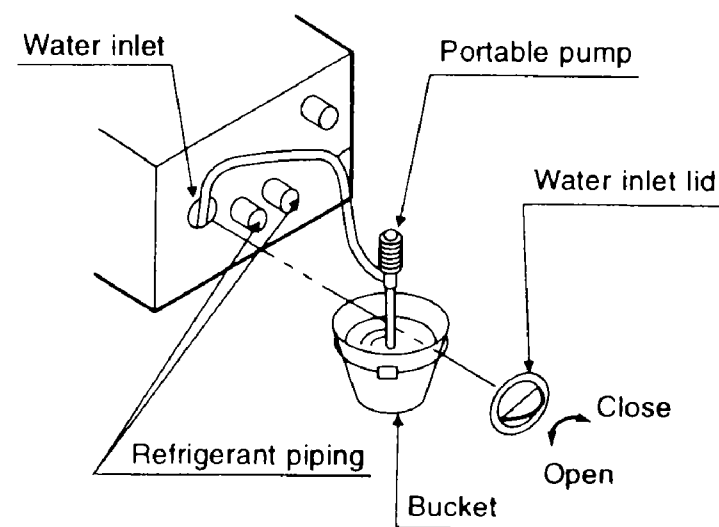

- Open the water inlet lid, add approximately 2500 cc of water gradually and check drainage flow.



#### WHEN ELECTRIC WIRING WORK IS FINISHED

- Check drainage flow during COOL running, explained under “TEST OPERATION”

#### WHEN ELECTRIC WIRING WORK IS NOT FINISHED

- Remove the electric parts box lid, connect a power supply and remote controller to the terminals. (Refer to the **How to CONNECT WIRINGS** (Installation Manual p.8)  
Next, press the inspection/test operation button “” on the remote controller. The unit will engage the test operation mode. Press the operation mode selector button “” until selecting FAN OPERATION “”. Then, press the ON/OFF button “”. The indoor unit fan and drain pump will start up. Check that the water has drained from the unit. Press “” to go back to the first mode.
- You can check whether drainage is satisfactory or not by removing the access opening lid and checking the water level of the drain pan through the access opening.
- **Be careful when doing so because the fan is turning at the same time.**

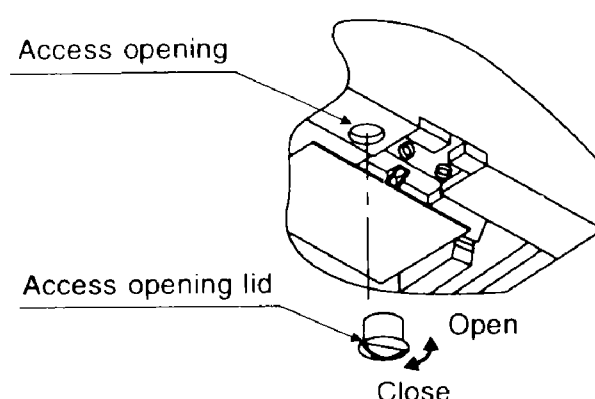
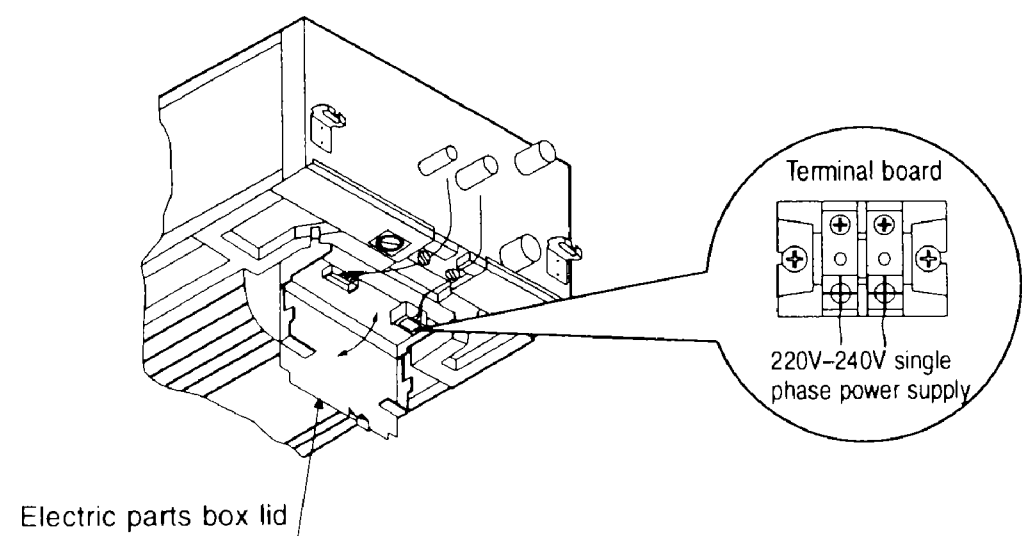

## 2. Ceiling mounted cassette type (FXZF Multi-flow)

### (1) Rig drain piping

- The diameter of the drain pipe should be greater than or equal to the diameter of the connecting pipe (vinyl tube; pipe size: 25mm; outer dimension: 32mm).
- Keep the drain pipe short and sloping downwards at a gradient of at least 1/100 to prevent air pockets from forming.
- If the drain hose cannot be sufficiently set on a slope, execute the drain raising piping.
- To keep the drain hose from sagging, space hanging wires every 1 to 1.5 m.

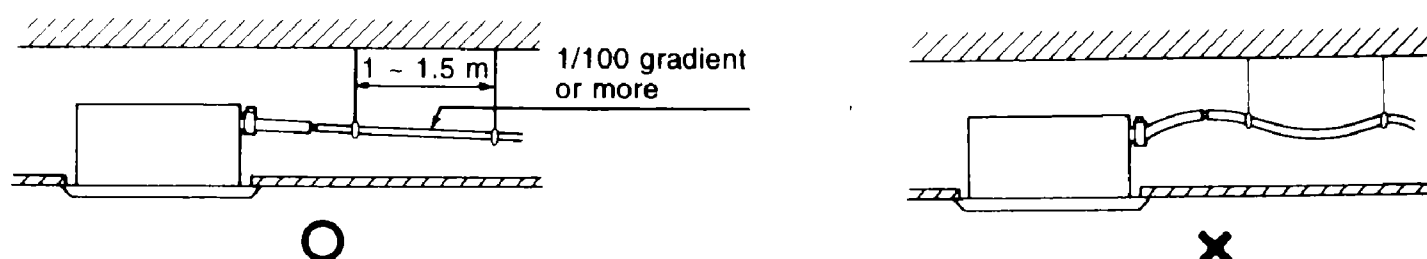

- Use the attached drain hose ① and clamp metal ②. Insert the drain hose into the drain socket, up to the white tape. Tighten the clamp until the screw head is less than 4 mm from the hose.
- Wrap the attached sealing pad over the clamp and drain hose to insulate.
- Insulate the drain hose inside the building.

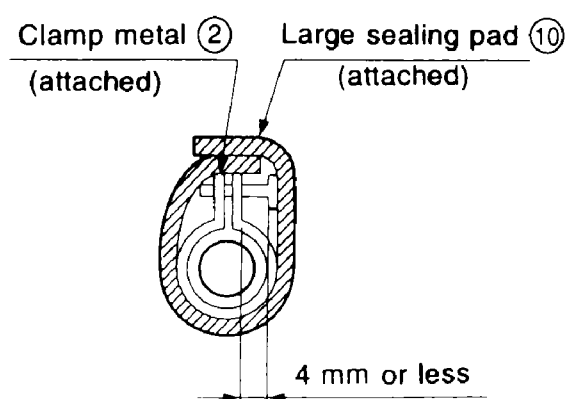
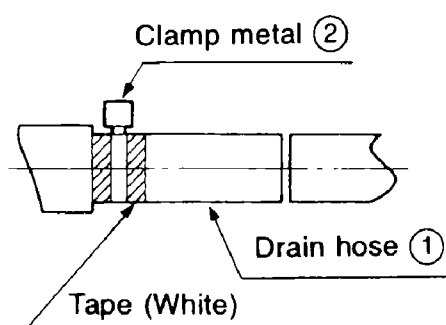

### (PRECAUTIONS FOR DRAIN RAISING PIPING)

- Install the drain raising pipes at a height of less than 530 mm.
- Install the drain raising pipes at a right angle to the indoor unit and no more than 300 mm from the unit.

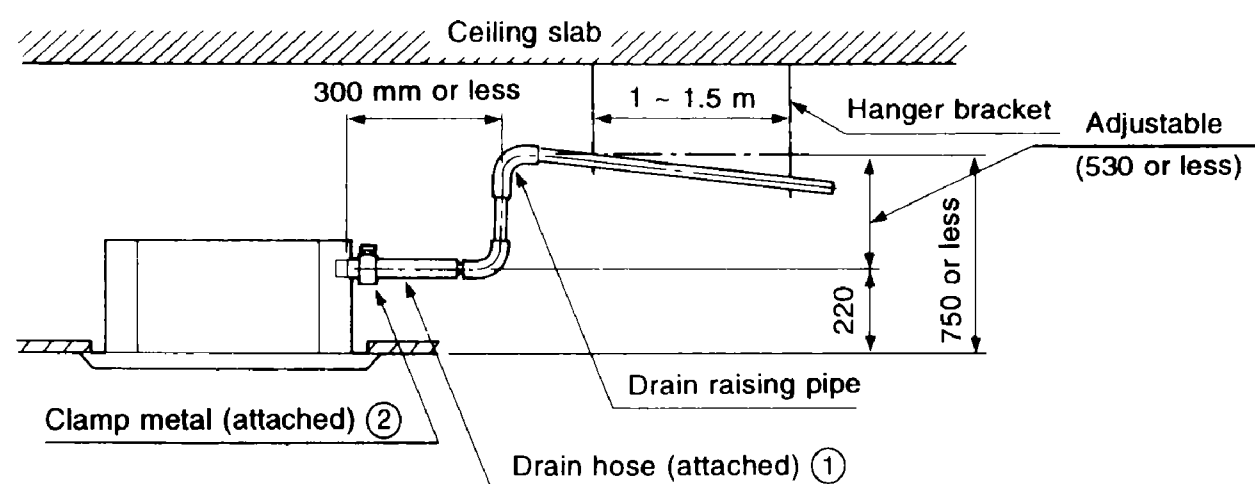

### <NOTE>

- The incline of attached drain hose ① should be 75 mm or less so that the drain socket does not have to stand additional force.

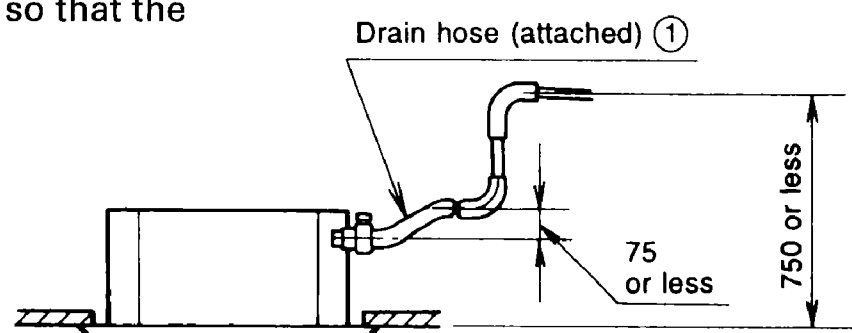

- If converging multiple drain pipes, install according to the procedure shown below.

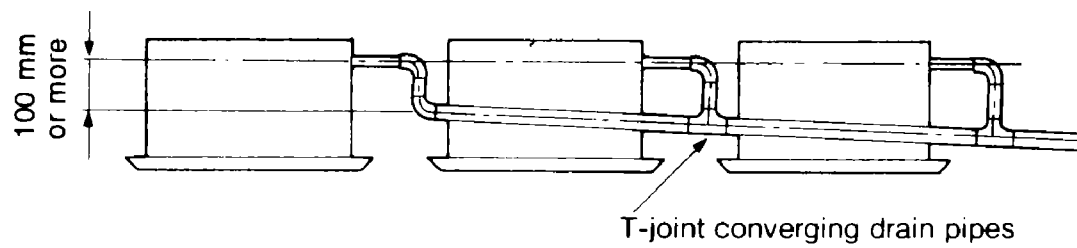

Select converging drain pipes whose gauge is suitable for the operating capacity of the unit.

(2) After piping work is finished, check drainage flows smoothly.





- Open the water inlet lid, add approximately 600 cc of water slowly and check drainage flow.

#### WHEN ELECTRIC WIRING WORK IS FINISHED

Check drainage flow during COOL running, explained under "TEST OPERATION".

#### WHEN ELECTRIC WIRING WORK IS NOT FINISHED

Remove the electric parts box lid, connect a power supply and remote controller to the terminals. (Refer to the **How to CONNECT WIRINGS** (Installation Manual p.10)

Next, press the inspection/test operation button "  " on the remote controller. The unit will engage the test operation mode. Press the operation mode selector button "  " until selecting FAN OPERATION "  ". Then, press the ON/OFF button "  ". The indoor unit fan and drain pump will start up. Check that the water has drained from the unit. Press "  " to go back to the first mode.

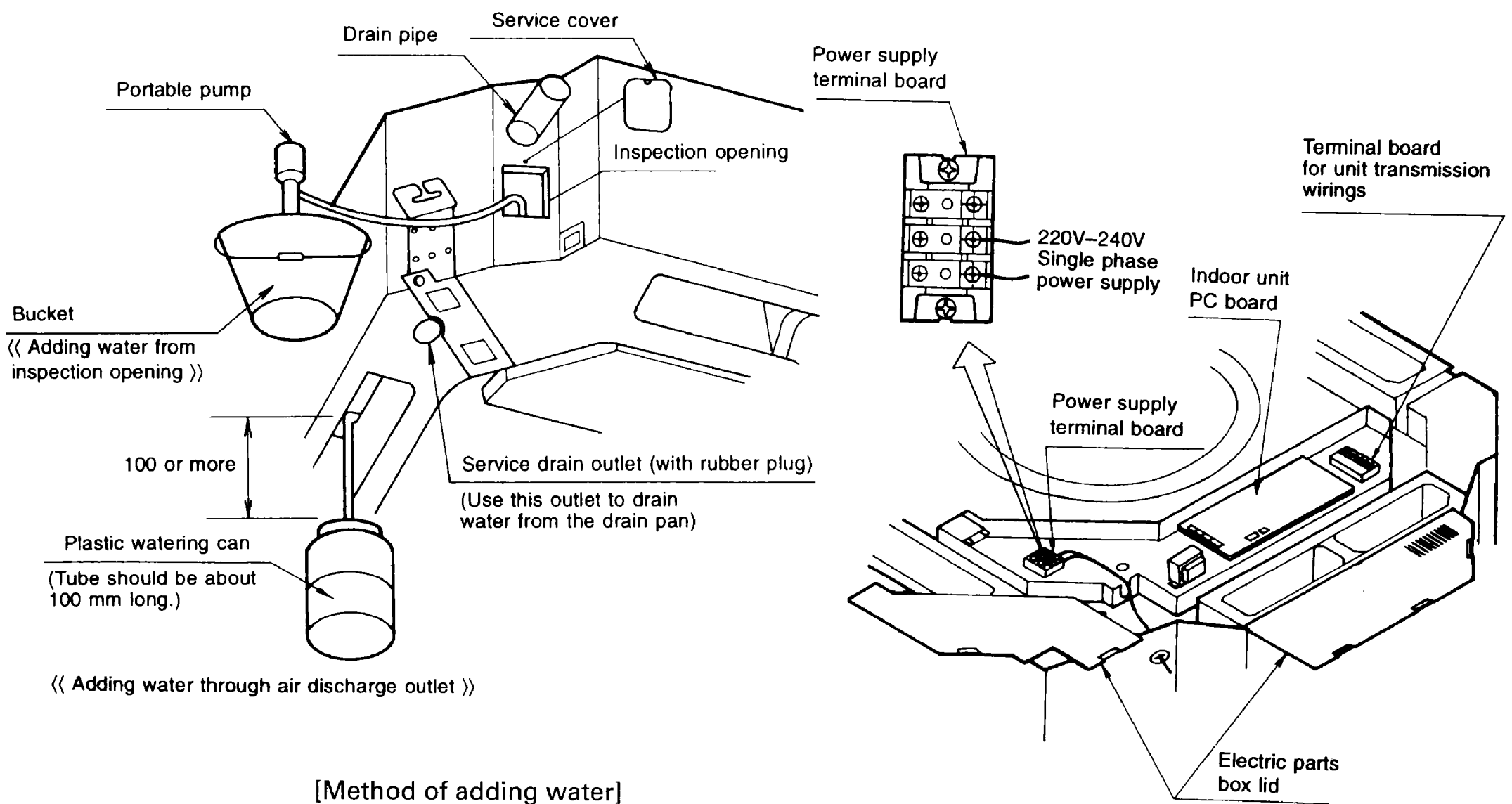

[Method of adding water]

### 3. Ceiling mounted cassette corner type (FXVK)

① Install the drain pipes.

- Keep piping as short as possible and slope it downwards so that air may not remain trapped inside the pipe.
- Keep pipe size equal to or greater than that of the connecting pipe (Vinyl pipe of 25 mm nominal diam. and 32 mm outer diam.).
- Use the attached drain hose and clamp.  
Tighten the clamp firmly.
- Insulate the clamp with the attached sealing pad.
- Insulate the drain hose inside the building.

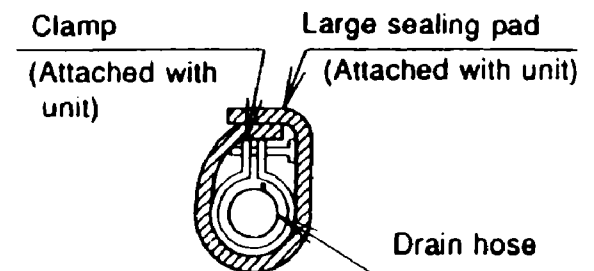
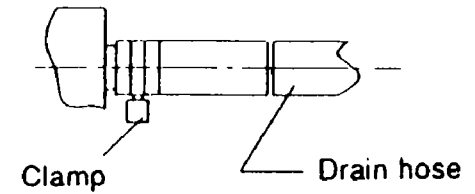
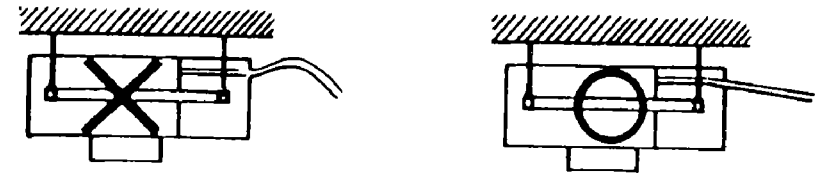

- If the drain hose cannot be sufficiently set on a slope, fit the hose with drain raising piping as shown in the drawing.  
Be sure to use the attached drain hose, drain raising pipe, clamp and drain pipe insulation
- Secure a downward gradient of 1/100 or more for the drain pipe. To accomplish this, mount supporting brackets at an interval of 1 - 1.5 m.

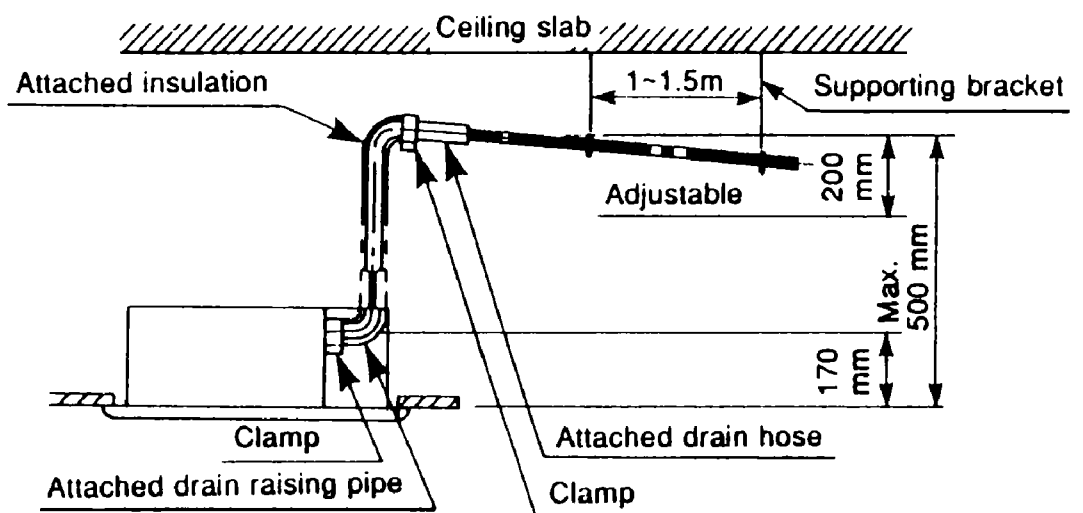

- Use the following outline if laying central drain piping.

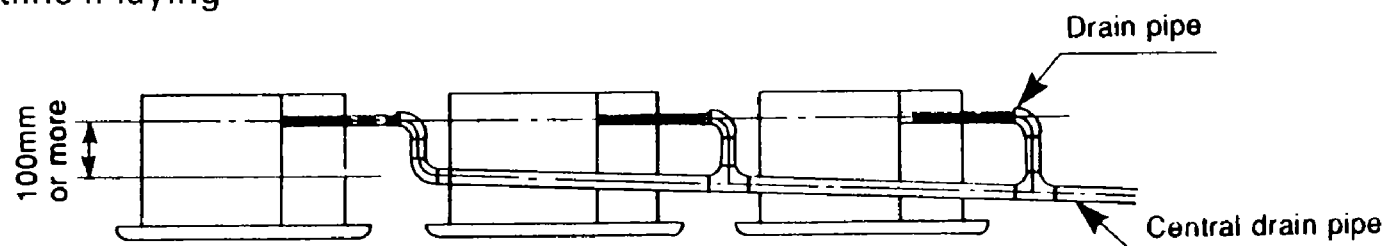

#### (Drain raising pipe laying procedure)

- (1) Connect the drain raising pipe and drain hose and fasten with a clamp.
- (2) Mount the drain pipe insulation and wrap with vinyl tape.
- (3) After completing steps (1) and (2), attach the drain raising pipe to the drain pipe connection port of the indoor unit and fasten with a clamp. (Do not connect any other pipes between the drain raising pipe and the indoor unit.)

- Adjust the drain raising height by turning the drain raising pipe as shown in the figure.

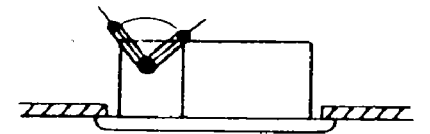

- (2) After piping, check to make sure draining flows smoothly.

#### If construction work for interconnecting piping is complete:

Using a plastic container for water filling, etc., gradually inject about 1,000 cc of water into the drain pan through the inspection hatch.

NOTE: To drain water from the drain pan, use the drainage port for maintenance.

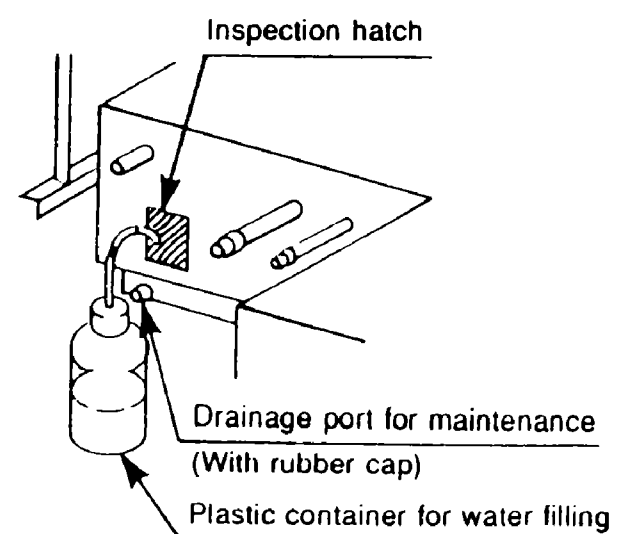







### WHEN ELECTRIC WIRING WORK IS FINISHED

Check drainage flow during COOL running, explained under "TEST OPERATION" .

### WHEN ELECTRIC WIRING WORK IS NOT FINISHED

Remove the electric parts box lid, connect a power supply and remote controller to the terminals. (Refer to the **How to CONNECT WIRINGS** (Installation Manual p.10)

Next, press the inspection/test operation button "  " on the remote controller. The unit will engage the test operation mode. Press the operation mode selector button "  " until selecting FAN OPERATION "  ". Then, press the ON/OFF button "  ". The indoor unit fan and drain pump will start up. Check that the water has drained from the unit. Press "  " to go back to the first mode.

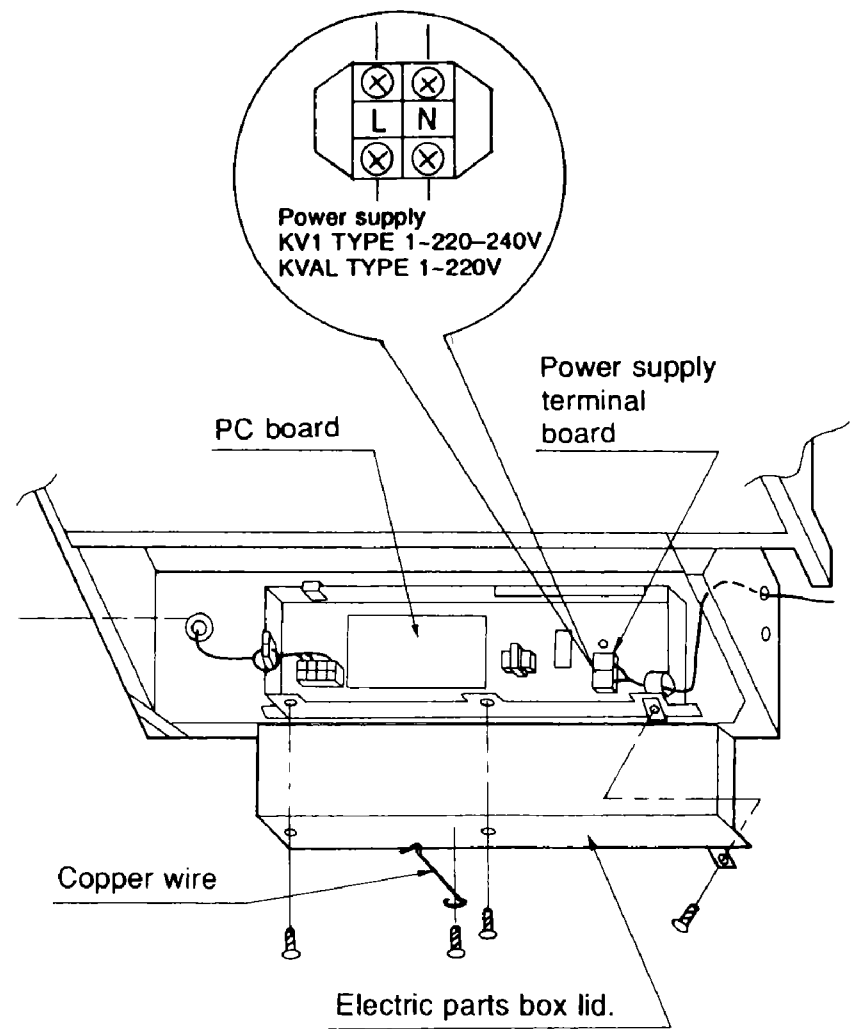

## 4. Ceiling mounted built-in type (FXYS)

- ① Install the drain pipes.
  - Keep piping as short as possible and slope it downwards so that air may not remain trapped inside the pipe.
  - Keep pipe size equal to or greater than that of the connecting pipe (Vinyl pipe of 25 mm nominal diam. and 32 mm outer diam.).
  - Use the attached drain hose and clamp. Tighten the clamp firmly.
  - Insulate the clamp with the attached sealing pad.
  - Insulate the drain hose inside the building.
  - If the drain hose cannot be sufficiently set on a slope, fit the hose with drain raising piping as shown in the drawing.

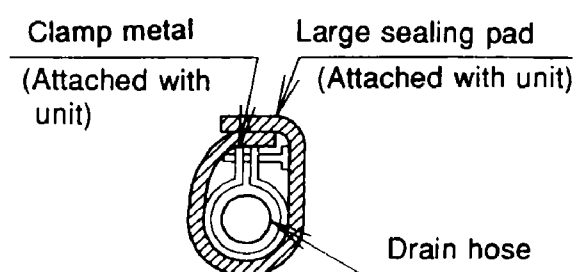
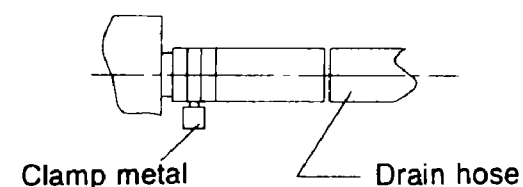
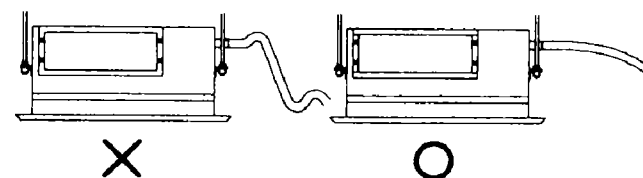

### <HOW TO INSTALL PIPING>

- (1) Connect the drain hose to the drain raising pipes, and insulate them.
- (2) Connect the drain hose to the drain outlet on the indoor unit, and tighten it with the clamp.
- (3) Insulate both metal clamp and drain hose with the attached sealing pad.

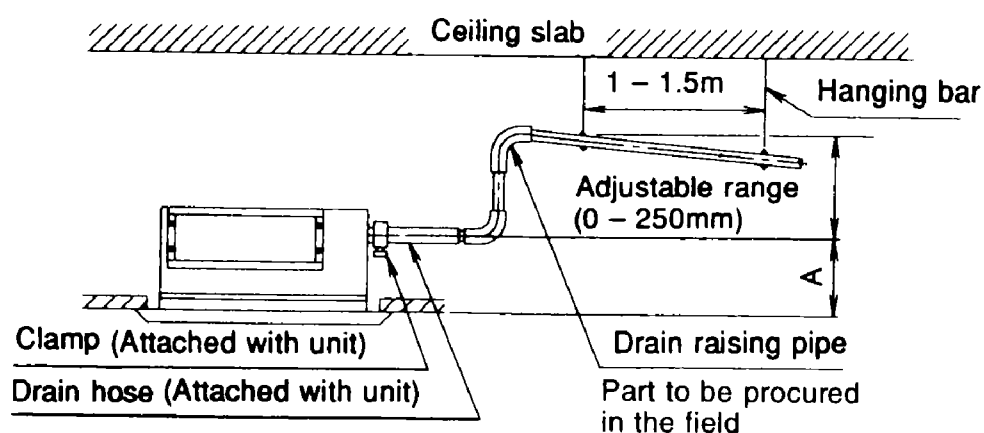

	A
When canvas bucket is installed	350 - 530
When air inlet panel is directly installed	275

- To ensure a downward slope of 1:100, install hanging bars every 1 to 1.5 m.
- If unifying multiple drain pipes, install pipes shown right.

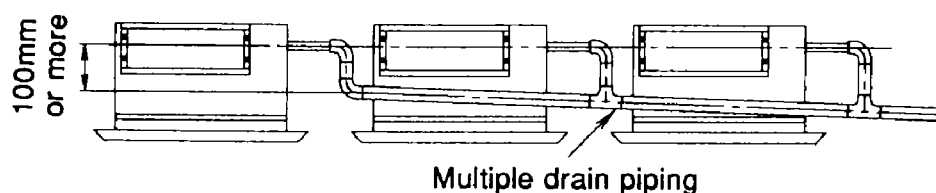

- ② After piping, check to make sure draining flows smoothly.

- Open the water inlet lid, add approximately 1000 cc of water gradually and check drainage flow.

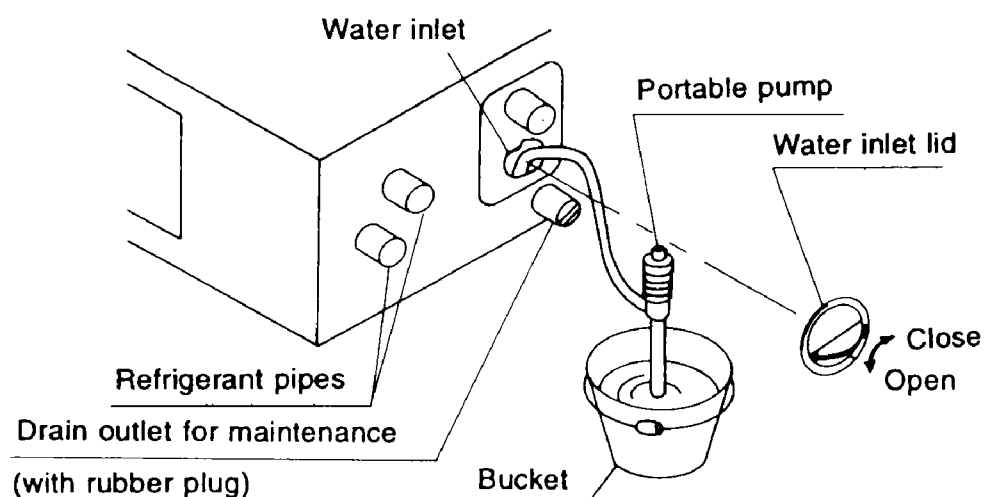

« Adding water from inspection opening »





Note: Use this outlet to drain water from the drain pan.

### WHEN ELECTRIC WIRING WORK IS FINISHED

Check drainage flow during COOL running, explained under “TEST OPERATION” .

### WHEN ELECTRIC WIRING WORK IS NOT FINISHED

Remove the electric parts box lid, connect a power supply and remote controller to the terminals. (Refer to the [How to CONNECT WIRINGS](#) (Installation Manual p.6)

Next, press the inspection/test operation button “  ” on the remote controller. The unit will engage the test operation mode. Press the operation mode selector button “  ” until selecting FAN OPERATION “  ”. Then, press the ON/OFF button “  ”. The indoor unit fan and drain pump will start up. Check that the water has drained from the unit. Press “  ” to go back to the first mode.

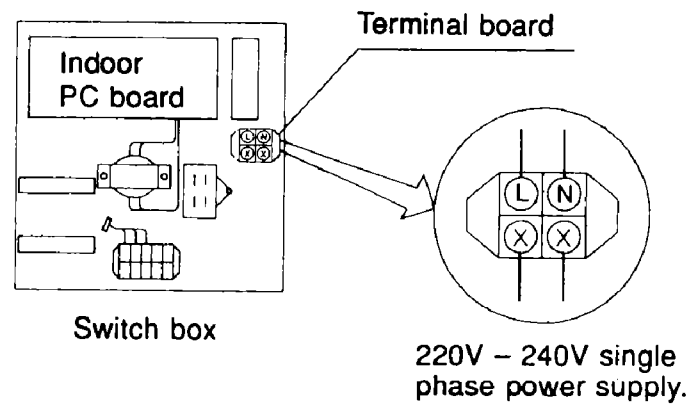

## (5) Electrical work

### (5)-1. Control wiring

#### 1) Compatible types of wire

##### Wiring Specifications

Wiring Type	Shield Wire (2 wire) (See NOTE 1, 2)
Size	0.75 — 1.25 mm <sup>2</sup>

NOTE 1. Sheathed wire may be used for transmission wirings, but they do not comply with EMI (Electromagnetic Interference) (EN55014). When using sheathed wire. EMI must conform to Japanese standards stipulated in the Electric Appliance Regulatory Act. (If using a sheathed wire, the grounding shown in the figure on the left is unnecessary.)

NOTE 2. For FXYA indoor unit, use sheathed wire.

#### 2) Problems arising from the use of unsuitable cable

a) When cable less than 0.75 mm<sup>2</sup> is used

Where the control wiring is particularly long the transmission signals may, for example, become unstable and the terminal relay cease to function. (Reduced voltage) The control system may become unduly subject to noise interference.

b) When cable more than 1.25 mm<sup>2</sup> is used

When wiring indoor units together, the terminal block will not be able to accommodate 2 cables simultaneously if the cables are larger than 1.25 mm<sup>2</sup>.

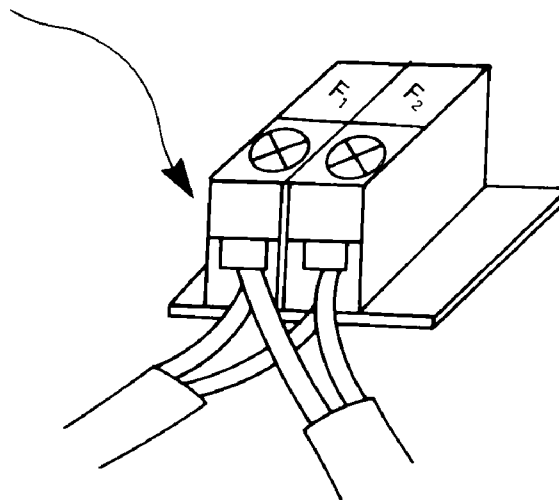

c) For multi-core cable

The greater play between wires, the more the transmitted wave is distorted and transmission destabilized.

- d) In the case of a remote controller with a three way selector for cooling, heating and ventilation, twin core cable should be used when the ventilation mode is not required and three core cable should be used when three way selection is required.
- e) Since there is a considerable risk of mixing high (220 to 240V) and low voltages in the case of, for example, a remote control PCB, multiple core cable must not be used.  
(Internal wiring regulations and dielectric strengths of cables are relevant here.)

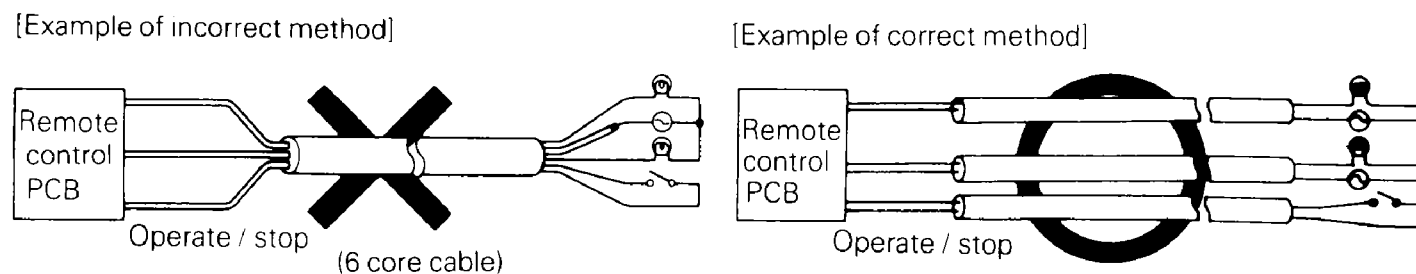

f) Other important points

- ① The refrigerant circuit and the indoor/outdoor connecting cables must correspond exactly.
- ② A suitable gap must be left between the control cables and the power supply cables where these are laid alongside each other. (see page 33)

## (5)-2. Power supply (cabling of main power supply)

### 1) Choosing a circuit breaker

The power supply work must conform to local regulations. In Japan, the relevant regulations are the MITI ordinance determining technical standards for electrical equipment, and the Internal Wiring Provisions.

#### a) The indoor unit circuit breakers

- In accordance with the provisions for internal wiring (JEAC8001-1986), power may be supplied by means of crossover lines between the indoor units in a single system branch circuit.

#### Branch circuit facility (Internal wiring provisions 305-2)

The motors must be set up with a dedicated branch circuit for each unit. However, where they correspond to any of the following situations, this limitation does not apply.

- ① When used in a 15A branch circuit of a 20A circuit breaker branch circuit

Note: It is recommended that the total rated capacity of the motors set up in a 15A branch circuit or a 20A circuit breaker branch circuit should be no more than 2.2kW.

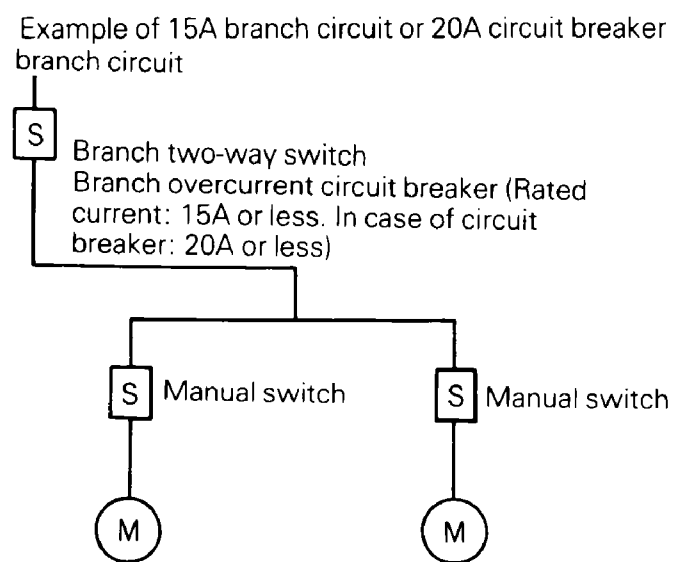

When using high static pressure indoor units the fan motors must have a large capacity. Single phase 220~240V branch circuits are therefore required for each indoor unit.

Example: Up to 10×2.5HP indoor units or 5×5HP indoor units can be wired together.

#### b) The outdoor unit circuit breaker

- A separate circuit breaker must be fitted for each unit.
- The motors incorporated into air conditioning system compressors are treated as special motors under the internal wiring provisions. The values which apply to normal motors are thus somewhat variance with those which apply to such compressor motors. You are recommended to adhere strictly to the procedures laid down in the technical materials included in, for example, the system design manuals.

Calculation of load (Refer to local regulation.)

With respect to the calculation of load for motors with special applications such as elevator, air conditioner and refrigerator motors, not only must the rated current be shown on the name plate of the said motor or piece of apparatus but it must also included all special characteristics or applications.

Note: The rated current for package air conditioners which use special purpose built-in compressor motors in their compressors in 1.2 times the operating current shown on the name plate.

### 2) Cable size

The thickness of the cables in the circuits (branch circuits) providing the main power supply to each item of apparatus must satisfy the following conditions:

- ① To have a current tolerance of 40% or more of the rated current of the overcurrent circuit breaker (wiring circuit breaker, etc.).
- ② To have a current tolerance of 125% or more of the rated current in cases where the rated current of the apparatus is 50A or less.
- ③ To have a current tolerance of 110% or more of the rated current in cases where the rated current of the apparatus is more than 50A.
- ④ To satisfy voltage drop standards.

### 3) Separation of control and power supply cables

- If control and power cables are run alongside each other then there is a strong likelihood of operational faults developing due to interference in the signal wiring caused by electrostatic and electromagnetic coupling. The table below indicates our recommendations as to the appropriate spacing of control and power cables where these are to be run side by side.

Current capacity of power cable		Spacing (d)
100V or more	10A or less	300mm
	50A	500mm
	100A	1000mm
	100A or more	1500mm

#### Note:

1. The figures are based on an assumed length of parallel cabling up to 100m. For lengths in excess of 100m the figures will have to be recalculated in direct proportion to the additional length of cable involved.
2. If the power supply waveform continues to exhibit some distortion the recommended spacing in the table should be increased.

If the cables are laid inside conduits then the following points must also be taken into account when grouping various cables together for introduction into the conduits.

- ① Power cables (including power supply to the air conditioner) and signal cables must not be laid inside the same conduit. (Power cables and signal cables must each have their own individual conduits.)
- ② In the same way, when grouping the cables, power and signal cables should not be bunched together.

#### ● Important points

##### ① Earthing

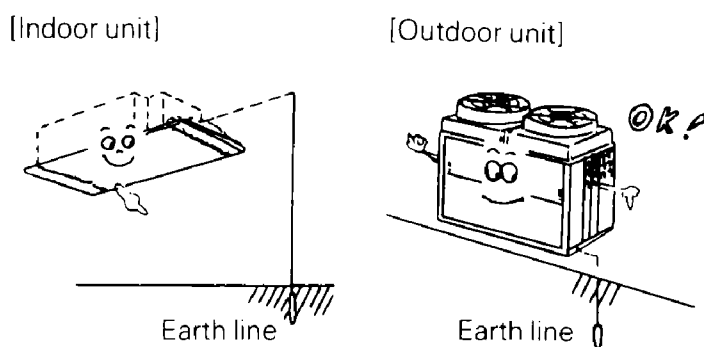

- Have the indoor and outdoor units both been earthed?
- ※ If the apparatus is not properly earthed then there is always a risk of electric shocks. The earthing of the apparatus must be carried out by a qualified person.

## (6) Duct work (indoor)

### • Operational steps

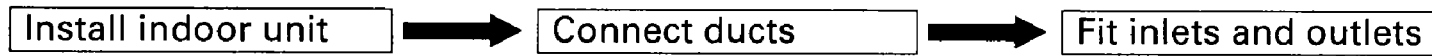

### 1) Taking account of noise and vibration

- a) Canvas joints must be used between the main unit and the air suction and discharge ducts. These fittings are designed to inhibit secondary noise resulting from the transmission of vibrations and operating noise from the main unit to the ducts or to the rest of the building.

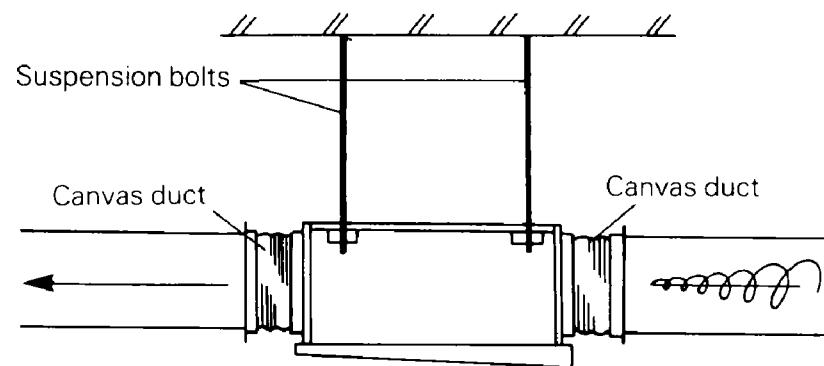

- b) The speed of the airflow should be taken into account when choosing air suction and distribution grills in order to keep wind noise to minimum.

### • Important points

- ① The air discharge duct must be thermally insulated.
- ② The canvas duct on the inlet side must be set in a metal framework.
- ③ The air suction and distribution grills should be positioned to take into account the possibility of short circuits.
- ④ Static pressure should be checked to ensure that the airflow is within the specified range.
- ⑤ The air filter must be easily detachable.



## (7) Thermal insulation work (refrigerant piping)

### • Operational steps

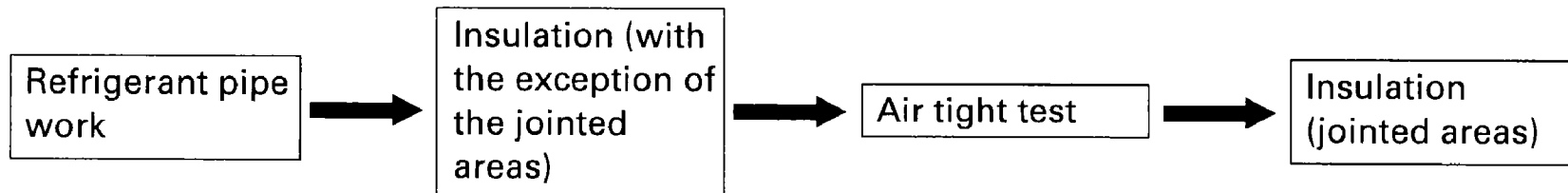

### 1) Materials

The thermal insulation materials which are used must be well able to withstand the heat from the pipes.

Example:

Heat pump type: Heat resistant polyethylene foam (heat resistance of at least 120°C)

Cooling only: Polyethylene foam (heat resistance of 100°C or more)

### 2) Essential points of thermal insulation

The insulation of jointed areas such as the soldered, flared or flanged sections should only be carried out after the successful completion of the air tight test.

Attention should be paid to the unit model and its operating conditions since there are occasions when the gas and liquid pipes also need to be thermally insulated.

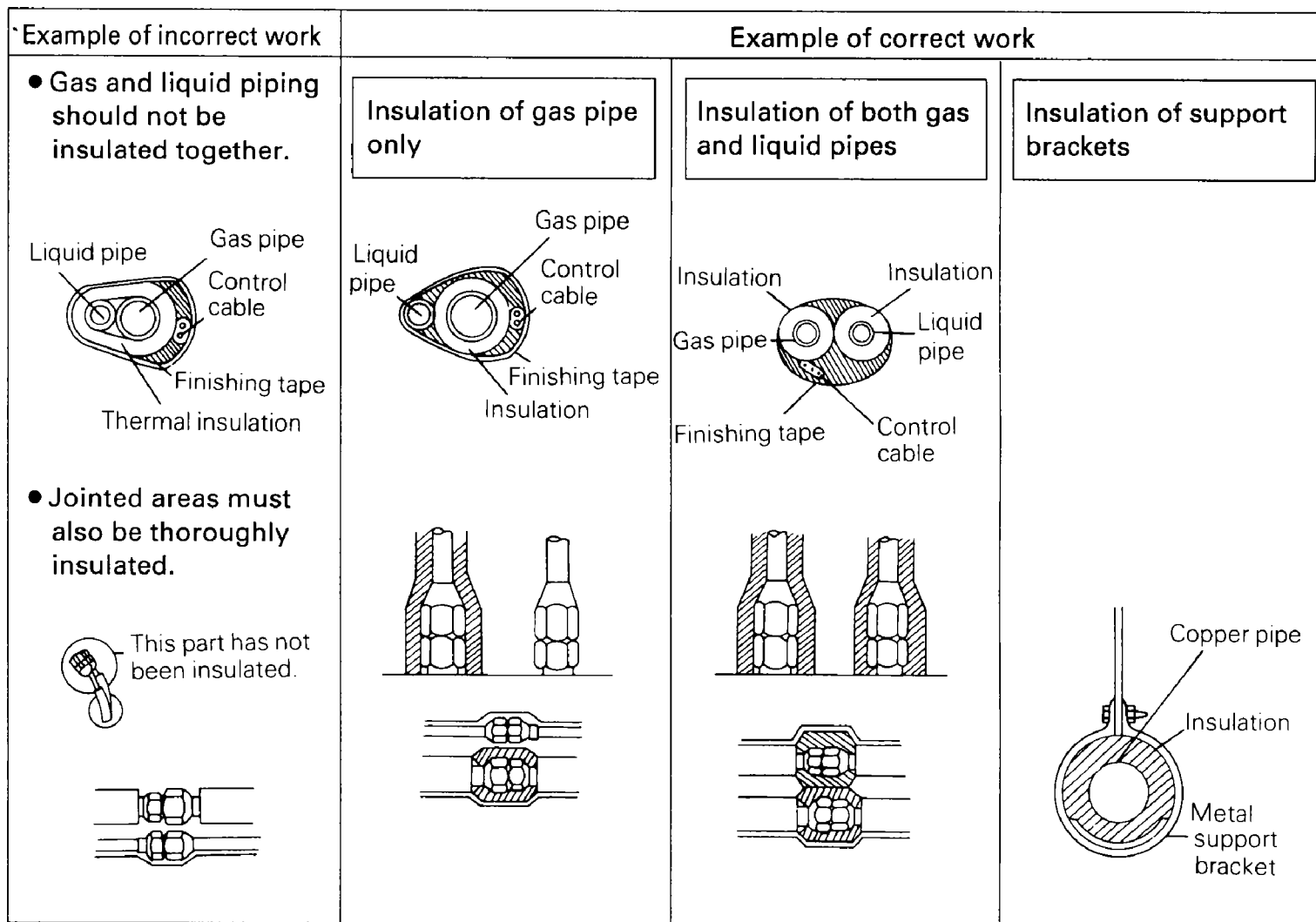

### • Important points

- The thickness of the thermal insulation material must be determined in the light of the pipe sizes.

Pipe size	Thickness of insulation material
6.4mm ~ 25.4mm	10mm or more
28.6mm ~ 38.1mm	15mm or more

- It will be necessary to increase the values in the above table for top floors or where conditions are hot and humid.
- Where a customer supplies his own specifications then these must be adhered to.
- Where it is anticipated that the air conditioning unit will be operated at external air temperatures of 10°C or less then thermal insulation will also be required for the liquid pipes.

## (8) Installation of outdoor unit

### • Operational steps



### 1) Foundation of units

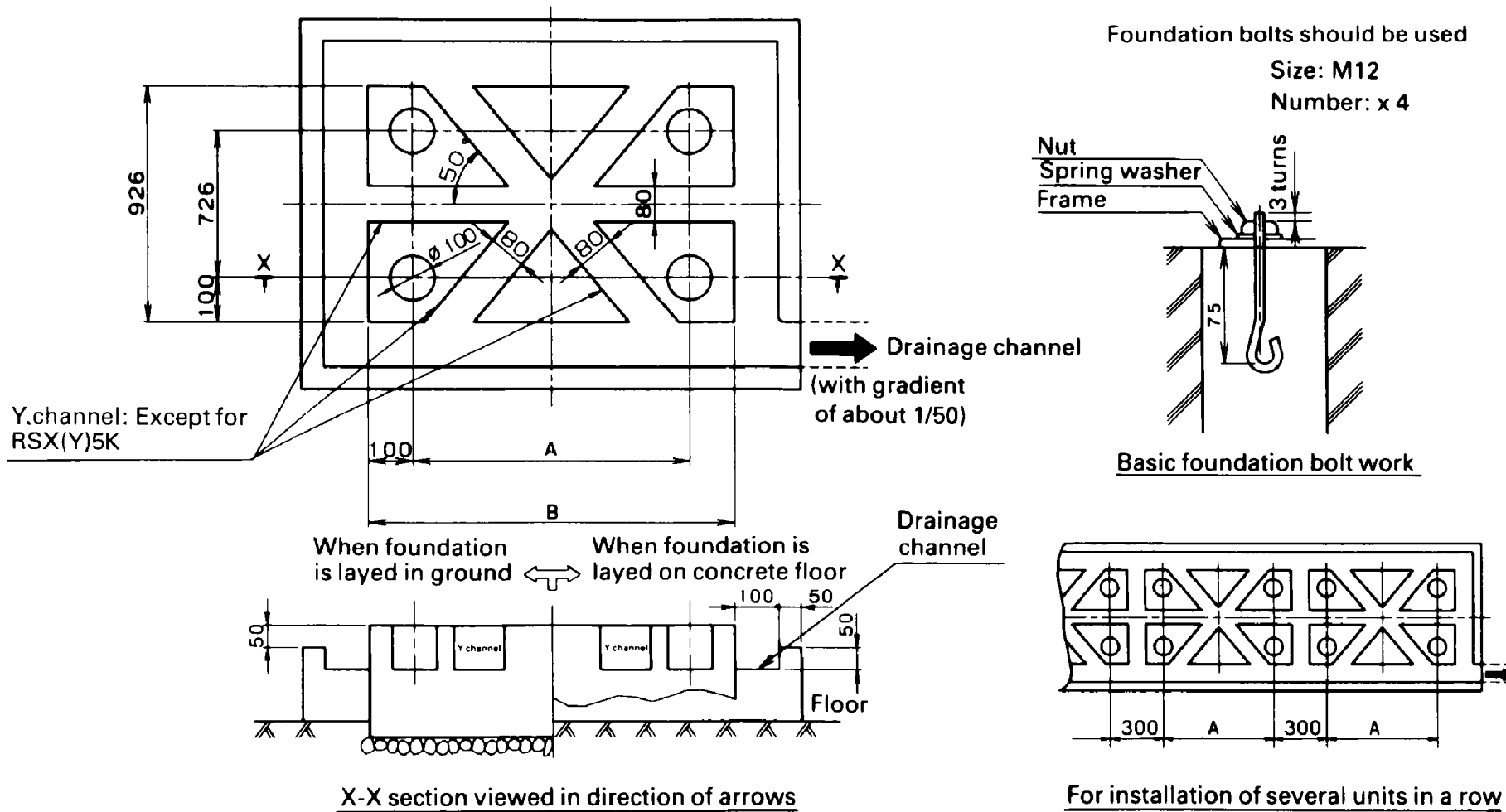

### Notes:

- 1 Standard concrete mix: 1 cement / 2 sand / 4 gravel with 10 reinforcing rods (approx. 300mm intervals).
- 2 Mortar should be used to level the surface. The edge of the concrete surface should be bevelled.
- 3 When setting the foundation on a concrete floor macadam is not required but the surface of the concrete should be broken up to make it uneven.
- 4 A drainage channel should be made around the foundation to cater for waste water around the machinery.
- 5 When installing a unit on the roof be sure to check the strength of the roof and pay special attention to waterproofing requirements.
- 6 Y channels are not required in the case of the RSX(Y)5K.

Model	A	B
RSX(Y)5K	355	555
RSX(Y)8K 10K RSEY8K 10K	100	1200

### ■ Bolt pitch

#### • RSX(Y)5K

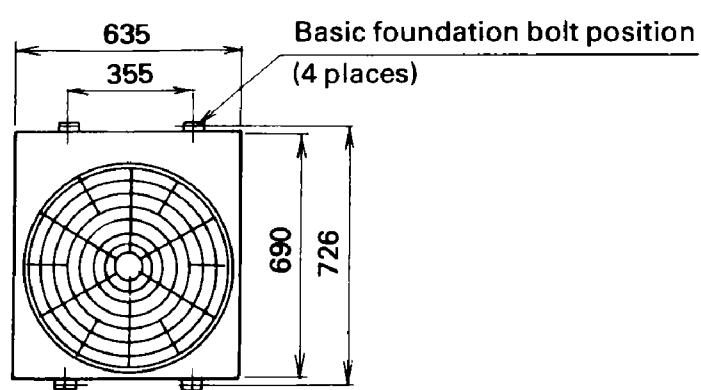

#### • RSX(Y)8K-10K, RSEY8K-10K

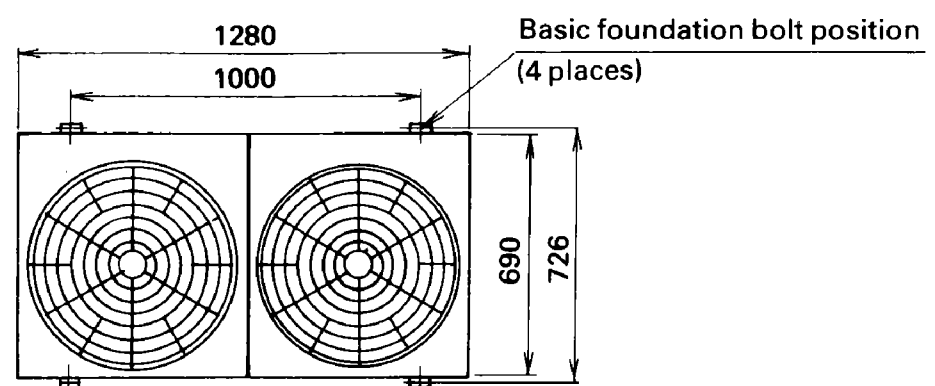

## ■ Caution in installation

- (1)
  - Execute the installation work by checking the foundation strength and levelness to avoid any occurrence of vibration and noise.
  - Fix the unit tightly with foundation bolts.  
(Prepare 4 sets of M12 foundation bolts with proper nuts and washers.)
  - The proper length of the foundation bolts from the surface of the base is 20mm.
  - The foundation must support the unit in the range above the shaped portion in the figure 1.
- (2)
  - Remove the fitting (yellow color) for loading as shown in the figure 2.
  - Tighten the installation bolt of compressor firmly again.
  - 2 fittings are attached to the front side of a single compressor.

## <CAUTION>

- Install the unit securely in case of earthquake an typhoon, cyclone, hurricane or other strong wind. The unit may topple or cause another accident if improperly set up.
- Pay special attention to the drainage in the environment of the unit by providing the drainage ditch in the environment of the foundation.
- Be sure to provide the waterproofing work in particular by paying attention to the floor strength if the unit is installed on the rooftop.

### RSX(Y)5K

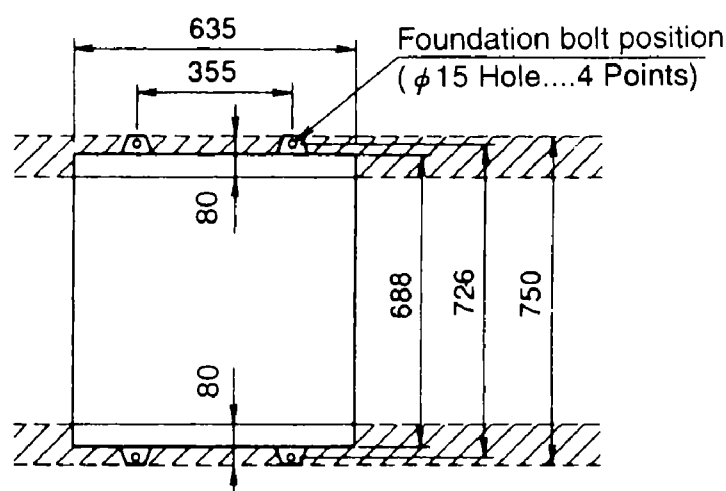
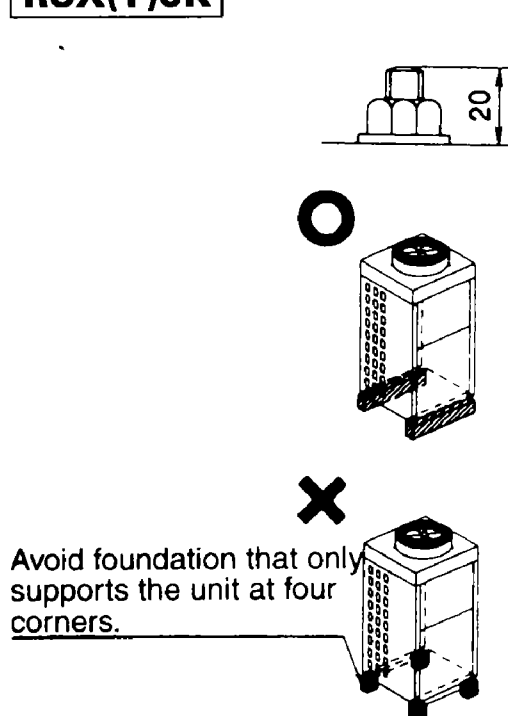

Outdoor unit foundation leg shape and foundation bolt position

Figure 1

If wild birds, etc. may enter the unit, block up the space (▨ portion) above the accessory pipe after refrigerant piping work. (When taking out the pipe)

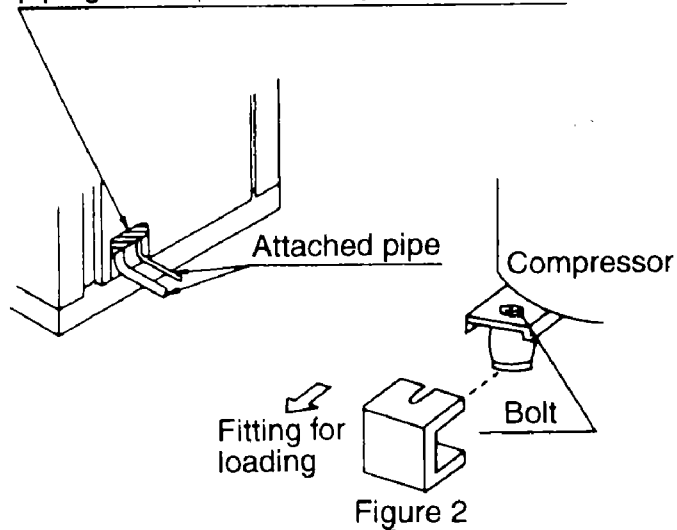
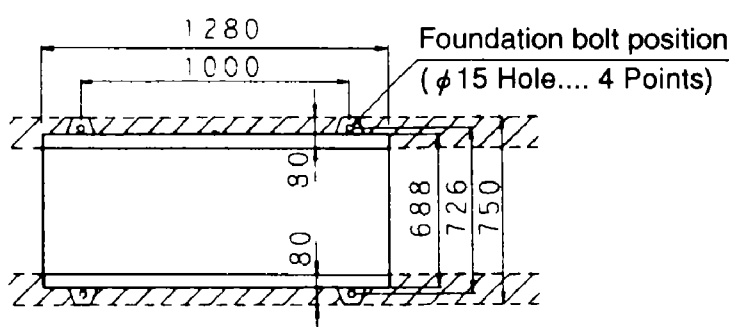
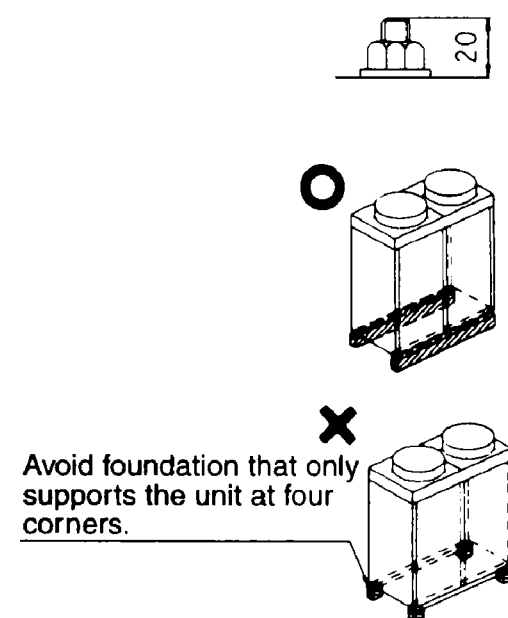

Figure 2

### RSX(Y)8K•10K



Outdoor unit foundation leg shape and foundation bolt position

Figure 1

If wild birds, etc. may enter the unit, block up the space (▨ portion) above the accessory pipe after refrigerant piping work. (When taking out the pipe)

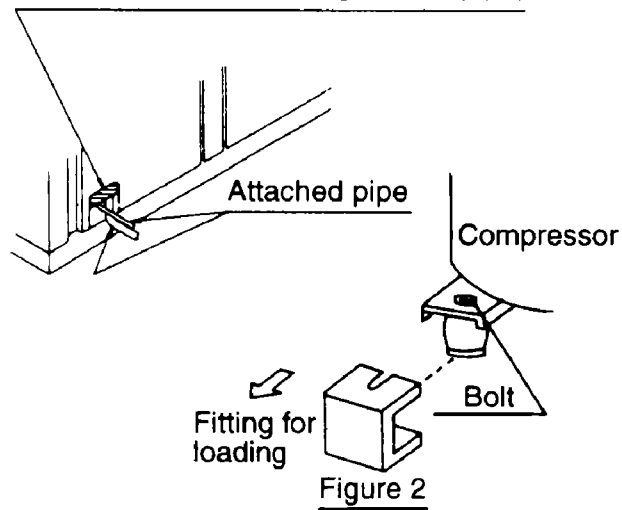
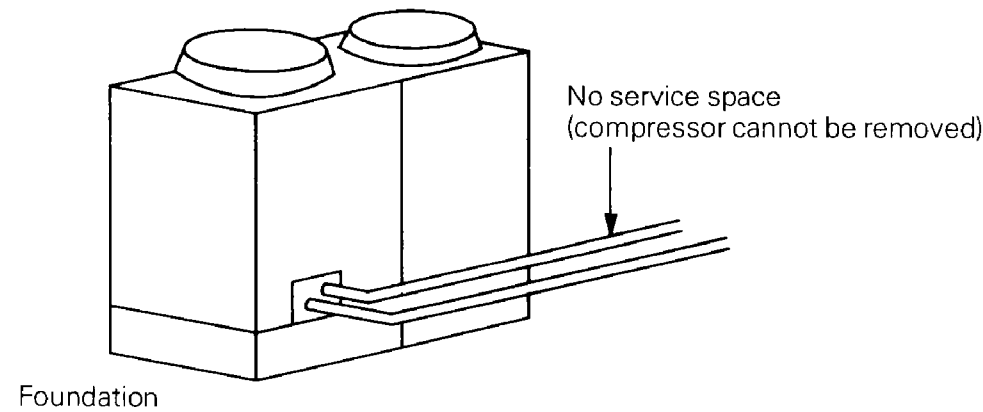

Figure 2

## 2) Service space

It is extremely important that enough space is left when installing the equipment to allow routine servicing and maintenance to be carried out without undue hindrance. It is particularly important to bear in mind the work which will be required if the compressor needs to be replaced. (The layout of the pipework can sometimes cause considerable difficulties if the compressor needs to be changed.)



## 3) Prevention of short circuits

The unit must be installed in a well ventilated area, otherwise short circuiting will occur. Special care should be taken in situations such as that illustrated in the diagram below since additional fittings such as air discharge ducts may also be required. (Attention should be paid to the duct's resistance)

Conditions for installation under the eaves

- When  $L \geq 1\text{m}$  then  $N$  must be  $\geq M$ .
- When  $L < 1\text{m}$  then  $K$  must be  $\geq M$ .

Where  $K$  is the required dimension for a single unit installation.

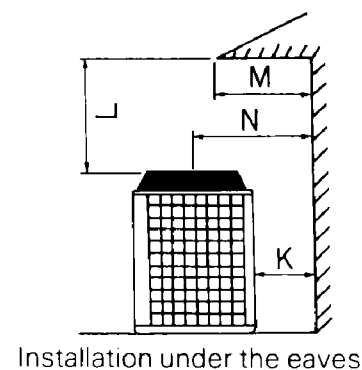

Conditions for installation where there is a horizontal obstruction above the unit

- When  $L \geq 3\text{m}$  then no special action is required.
- When  $L < 3\text{m}$  then an air discharge duct with resistance within  $3\text{mmH}_2\text{O}$  is required.

Where  $K$  measures a little more than the required  $K$  dimension for a single unit installation.

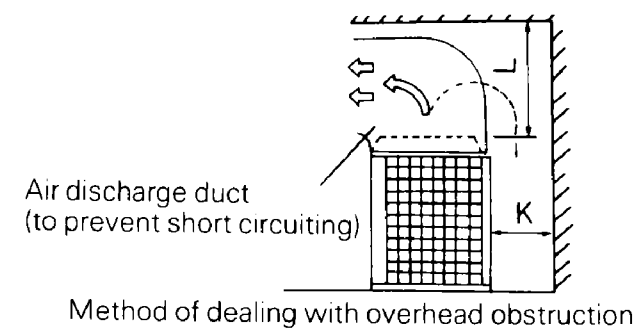

#### 4) Techniques for prevention of snow accumulation in areas of high snowfall

- ① Snow must be prevented from accumulating around the outdoor unit's air inlet and air discharge outlet and one possible answer would be to fit a snow hood.

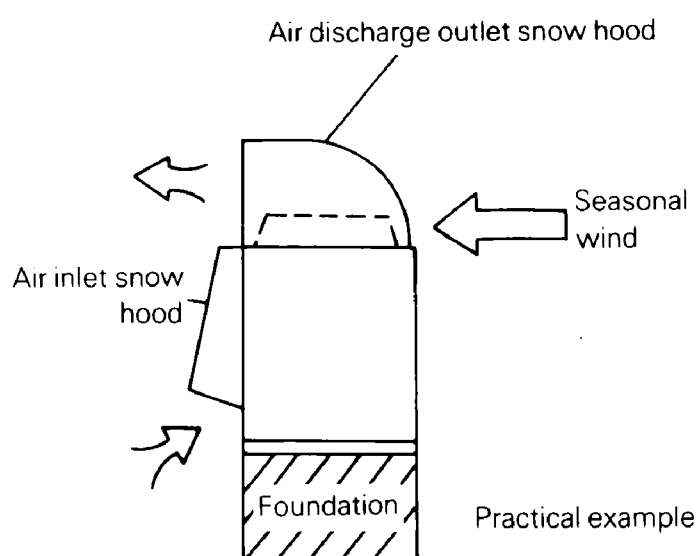

[Points relating to design of snow hood]

- In order to ensure the required outdoor unit airflow the duct resistance must be less than the permissible external static pressure of 3 mmH<sub>2</sub>O.
- The structure must be robust enough to withstand the weight snow building up on it and strong winds or typhoons.
- The construction of the unit should be such as to avoid short circuiting between suction air and discharge air. A snow hood is available from Daikin as an optional accessories so please make use of it where necessary.

- ② The unit should be oriented in such a way as to prevent the air heat exchanger from facing into driving snow.
- ③ The outdoor unit should be set at a higher level in relation to the surface on which it is mounted than the anticipated depth of snow accumulation in order to prevent it from being buried.
- ④ Measures to combat lightning and burying by drifting snow.  
The proposed installation spot should be thoroughly investigated and on no account should the unit be placed beneath eaves or trees where snow is likely to drift.

#### 5) When units are located on different floors

Special care must be taken with respect to short circuits when units are installed on different floors.

## 6) Management of available space when placing several units in close proximity to each other

When placing several units in close proximity to each other some thought should be given to the possibility of short circuiting and also to the provision of adequate space for servicing. (For more detailed information please refer to the system design materials.)

Example: Inverter K Series

RSX(Y)8K.10K

### Single unit installation

(Pattern 1)

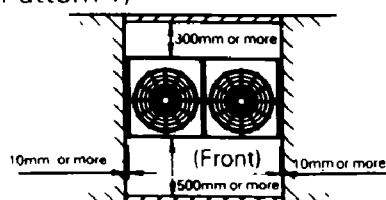

(Pattern 2)

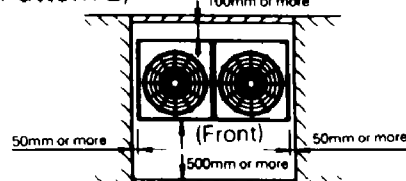

(Pattern 3)

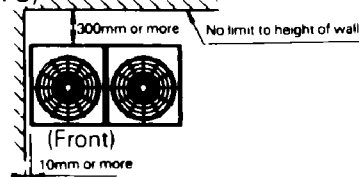

### Serial unit installation

(Pattern 1)

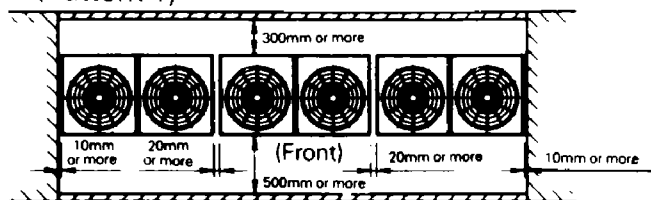

(Pattern 2)

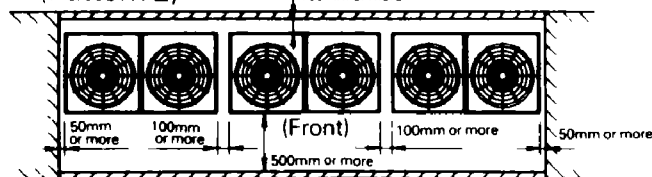

(Pattern 3)

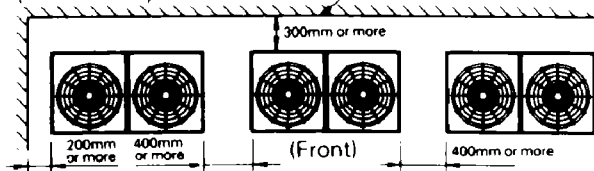

### Grouped unit installation

(Pattern 1)

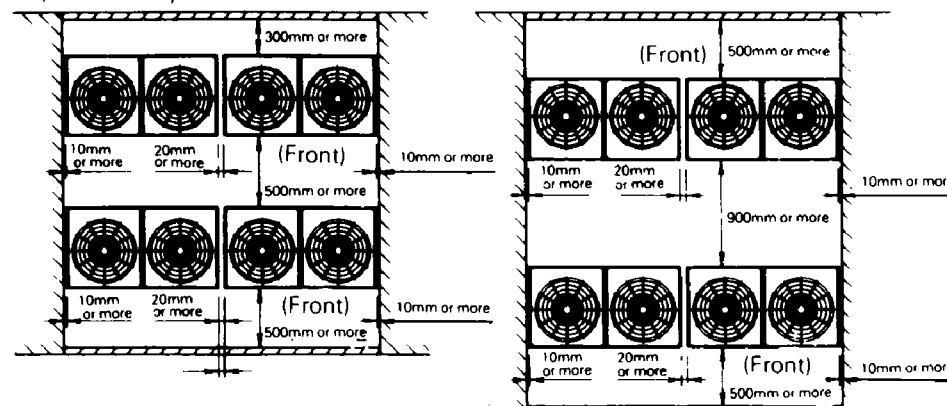

(Pattern 2)

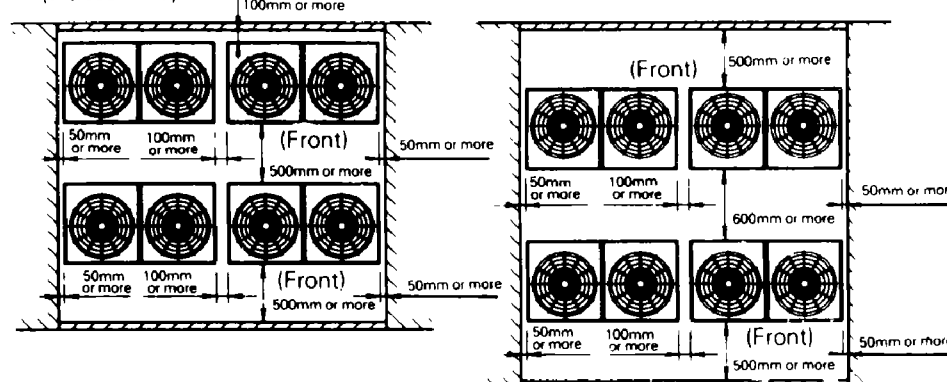

NOTE 1. Height of walls in case of Patterns 1 and 2:

Front: 1500mm

Suction side: 500mm

Side: Height unrestricted

2. If the above wall heights are exceeded then  $h/2$  and  $h/2$  should be added to the front and suction side service spaces respectively as shown in the figure on the right.

3. When installing the units the most appropriate pattern should be selected from those shown above in order to obtain the best fit in the space available always bearing in mind the need to leave enough room for a person to pass between units and wall and for the air to circulate freely. (If more units are to be installed than are catered for in the above patterns your layout should take account of the possibility of short circuits.)

4. The units should be installed to leave sufficient space at the front for the on site refrigerant piping work to be carried out comfortably.

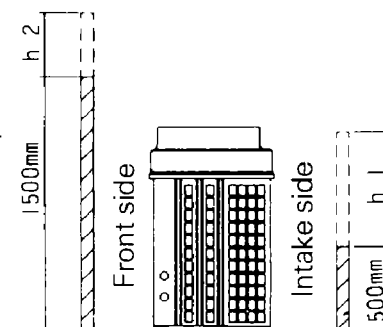

## 7) Points to be considered when installing the inverter air conditioner

Room for servicing should be allowed in accordance with the rules of installation.

Note: The inverter air conditioner sometimes experiences noise interference from AM broadcast. Due consideration should therefore be given as shown in the figure to the proximity of other electronic equipment such as radios, PCs or stereos when selecting an installation location for the unit and designing the layout for the wiring.

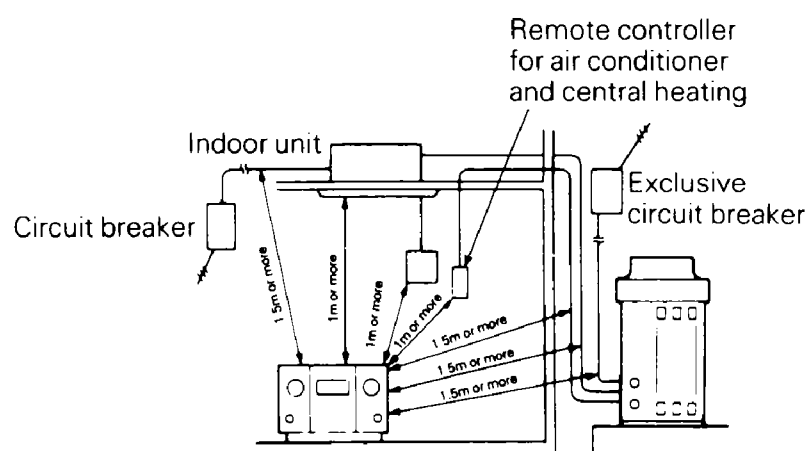

## (9) Air tight test

### • Operational steps

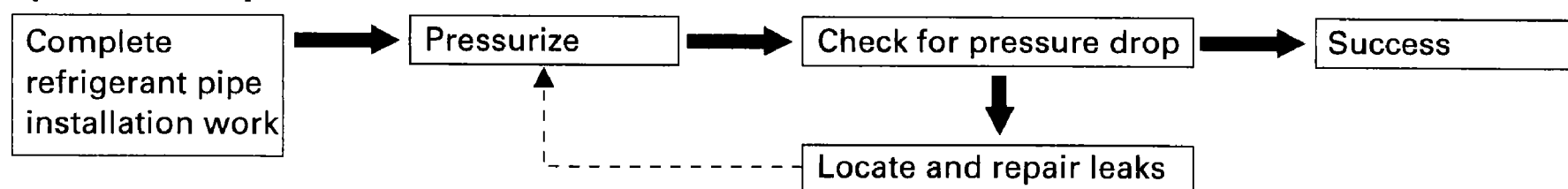

### 1) Essential points of testing (maintaining pressure over a period)

The key to successful testing is strict adherence to the following procedure:

a) The liquid and gas piping in each refrigerant system should be pressurized in turn in accordance with the following steps. (Nitrogen gas must be used.)

- Step 1: increase pressure to 3.0 kg/cm<sup>2</sup> for 3 minutes or more } Indicates existence of major leaks
- Step 2: increase pressure to 15.0 kg/cm<sup>2</sup> for 3 minutes or more }
- Step 3: increase pressure to 28.0 kg/cm<sup>2</sup> for approx. 24 hours } Indicates existence of minor leaks

※ Increasing the system pressure to 28.0 kg/cm<sup>2</sup> does not guarantee the identification of minor leaks if pressure is maintained for only a short time. It is therefore recommended that the system remain pressurized in accordance with Step 3 above for at least 24 hours.

Note: The gas pressure must on no account be increased beyond 28.0 kg/cm<sup>2</sup>.

b) Check for pressure drop

If there is no drop in pressure then the test is deemed a success.

If the pressure drops then the leak must be located. See following page.

However, if there is a change in the ambient temperature between the pressurizing stage and the time when you check for a drop in pressure then you will have to adjust your calculations accordingly since a change of 1°C can account for a pressure change of approximately 0.1 kg/cm<sup>2</sup>.

Compensating adjustment value:

(temperature at time of pressurizing – temperature at time of checking) × 0.1

Example:

Time of pressurizing: 28.0 kg/cm<sup>2</sup> 25°C

24 hours later: 27.5 kg/cm<sup>2</sup> 20°C

The pressure drop in such a case is deemed to be zero (successful test).

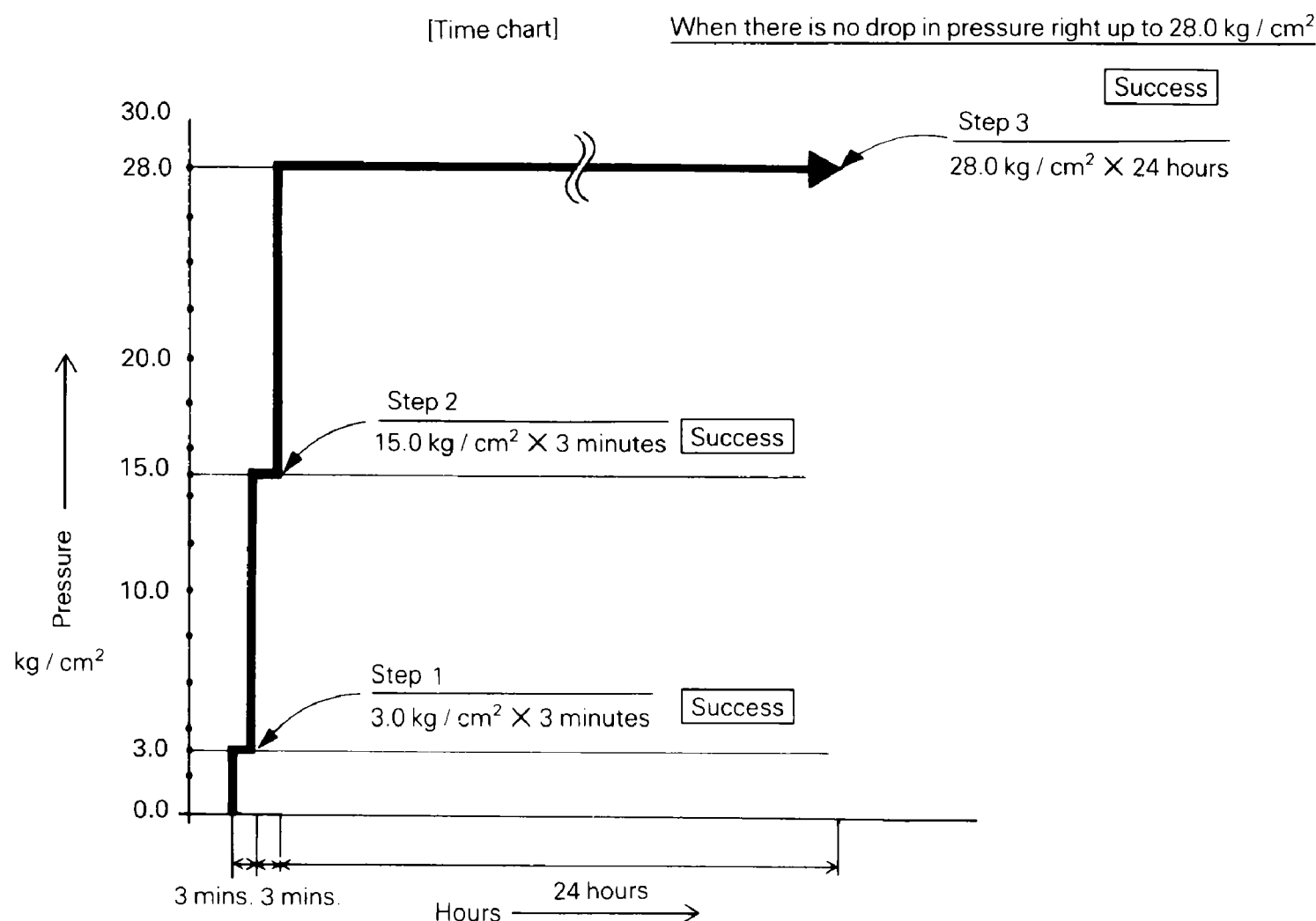

## 2) Checking for leaks

[Check 1] (Where pressure falls while carrying out Steps 1 to 3 described on previous page)

- Check by ear……Listen for the sound of a major leak.
- Check by hand……Check for leak by feeling around jointed sections with hand.
- Soap and water check (※Snoop)……Bubbles will reveal the presence of a leak.

[Check 2] (When searching for a minor leak or when there has been a fall in pressure while the system has been fully pressurized but the source of the leak cannot be traced.)

- ① Release the nitrogen until the pressure reaches 3.0 kg/cm<sup>2</sup>.
- ② Increase pressure to 5.0 kg/cm<sup>2</sup> using gaseous flon gas (R22). (Nitrogen and flon gas mixed)
- ③ Search for the source of the leak using a detector such as a halide torch or a propane or electric detector.
- ④ If the source of the leak still cannot be traced then repressurize with nitrogen up to 28.0 kg/cm<sup>2</sup> and check again.  
(The pressure must not be increased to more than 28.0 kg/cm<sup>2</sup>.)

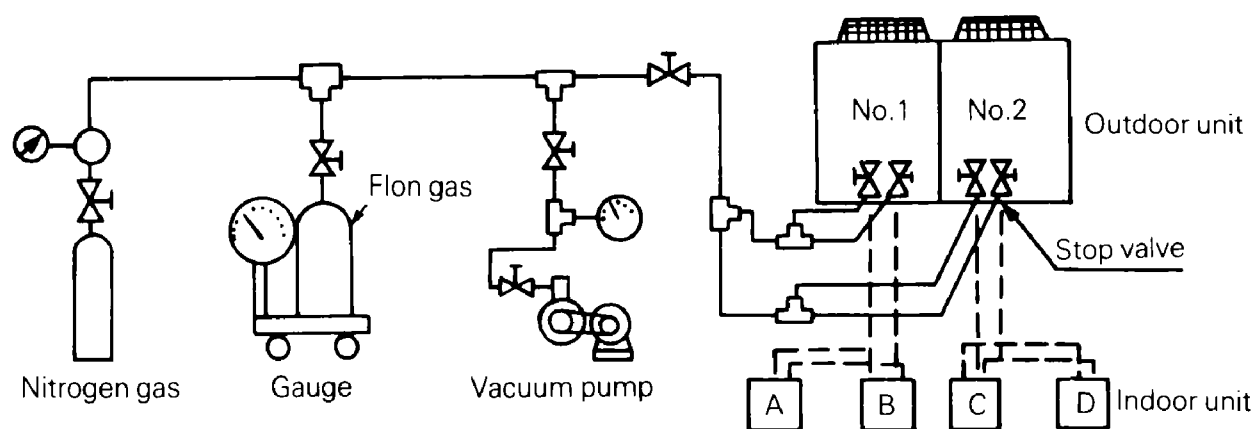

### ● Important points

- ① Where the lengths of piping involved are particularly long then the air tight test should be carried out block by block.

Example: {  
1) Indoor side  
2) Indoor side + vertical pipes  
3) Indoor side + vertical pipes + outdoor side



## (10) Vacuum drying

### 1) What is vacuum drying?

Vacuum drying is:

"The use of a vacuum pump to vaporize (gasify) the moisture (liquid) inside the pipes and expel it leaving the pipes completely dry inside."

At 1 atm (760 mmHg) the boiling point (evaporating temperature) of water is 100°C but if a vacuum is created inside the pipes using a vacuum pump then the boiling point is rapidly reduced as the degree of the vacuum is increased. If the boiling point is reduced to a level below that of the ambient temperature then the moisture in the pipes will evaporate.

Example:

With an ambient temperature of 7.2°C, vacuum drying is only possible with a vacuum in excess of 8mmHg. Before attempting vacuum drying, it is important to fully understand how to choose and maintain a vacuum pump.

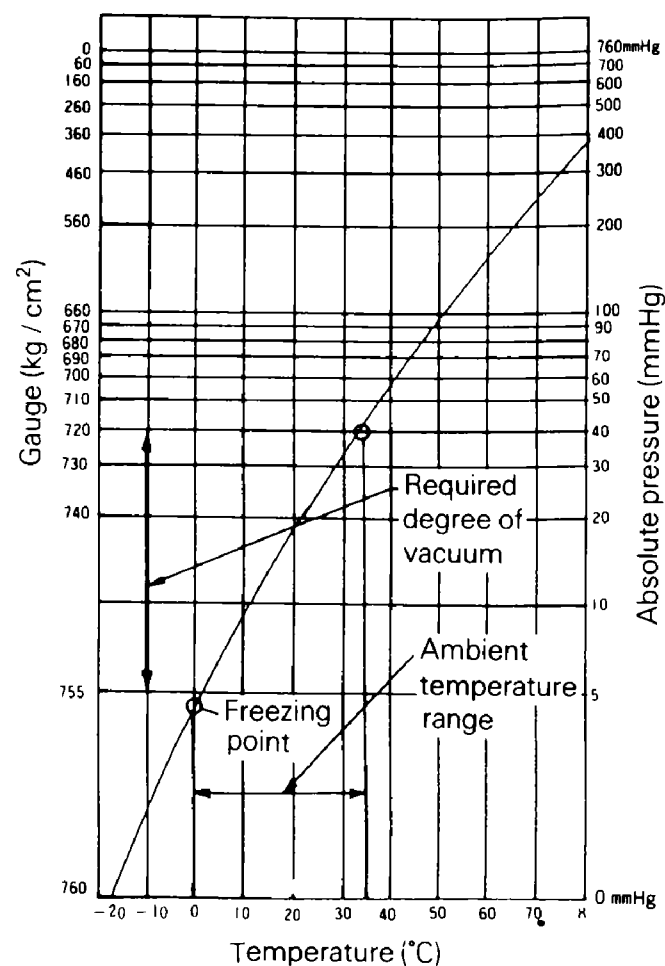

### 2) Choosing a vacuum pump

The two following points should be borne in mind when selecting a vacuum pump:

- ① A pump capable of producing a high degree of vacuum should be chosen. (Capable of producing a vacuum in excess of 5 mmHg)
- ② A comparatively high degree of expulsion capacity is required. (approx. 40 ℓ /min)

Before starting the vacuum drying operation check the pressure gauge to make sure that the pump is capable of producing a maximum vacuum in excess of 5 mmHg.

Boiling point of water (°C)	Atmospheric pressure (mmHg)	Degree of vacuum (mmHg)
40	55	-705
30	36	-724
26.7	25	-735
24.4	23	-737
22.2	20	-740
20.6	18	-742
17.8	15	-745
15.0	13	-747
11.7	10	-750
7.2	8	-752
0	5	-755

Oil rotary pumps must have an oil change every 1 to 2 months and the degree of vacuum which the pump is capable of producing must also be checked.

(Reference) Types of vacuum pump with respective maximum degree of vacuum

Type	Maximum degree of vacuum Expulsion capacity	Use	
		Vacuum drying	Air expulsion
Oil rotary (oil using)	0.02 mmHg 100 ℓ /min	Suitable	Suitable
Oilless rotary (No need of oil)	10 mmHg 50 ℓ /min	Unsuitable	Suitable
	0.02 mmHg 40 ℓ /min	Suitable	Suitable

← Many handy pumps fall into this category

### 3) Vacuum drying procedure

There are two vacuum drying methods and the appropriate one should always be chosen to conform with individual local conditions.

[Normal vacuum drying] .....The standard method

[Operational steps]

- ① Vacuum drying (1st time): Connect a manifold gauge to the service port of the liquid or gas pipe and operate the vacuum pump for at least 2 hours.  
(The degree of vacuum produced should be in excess of 5 mmHg)  
 If after 2 hours the vacuum produced has not exceeded 5 mmHg then either there is moisture in the pipe or there is a leak. Operate the vacuum pump for a further hour.  
 If, even after 3 hours, the vacuum has not reached 5 mmHg then check the system for a leak.
- ② Carry out maintained vacuum test.  
 Produce a vacuum in excess of -755 mmHg and do not release it for an hour or more. Check the vacuum gauge to make sure that it has not risen. (If the gauge does rise then there is still moisture in the pipe or there is a leak somewhere.)
- ③ Additional charge of refrigerant.  
 Connect the charging cylinder to the liquid pipe service port and charge with the required amount of refrigerant.
- ④ Open stop valve to the full.  
 Open the stop valves on the liquid and the gas pipes to the full.

Note: Vacuums should be produced in both the liquid and the gas pipes.  
 (Because there are a large number of functional components in the indoor unit which cut off the vacuum mid-way through)

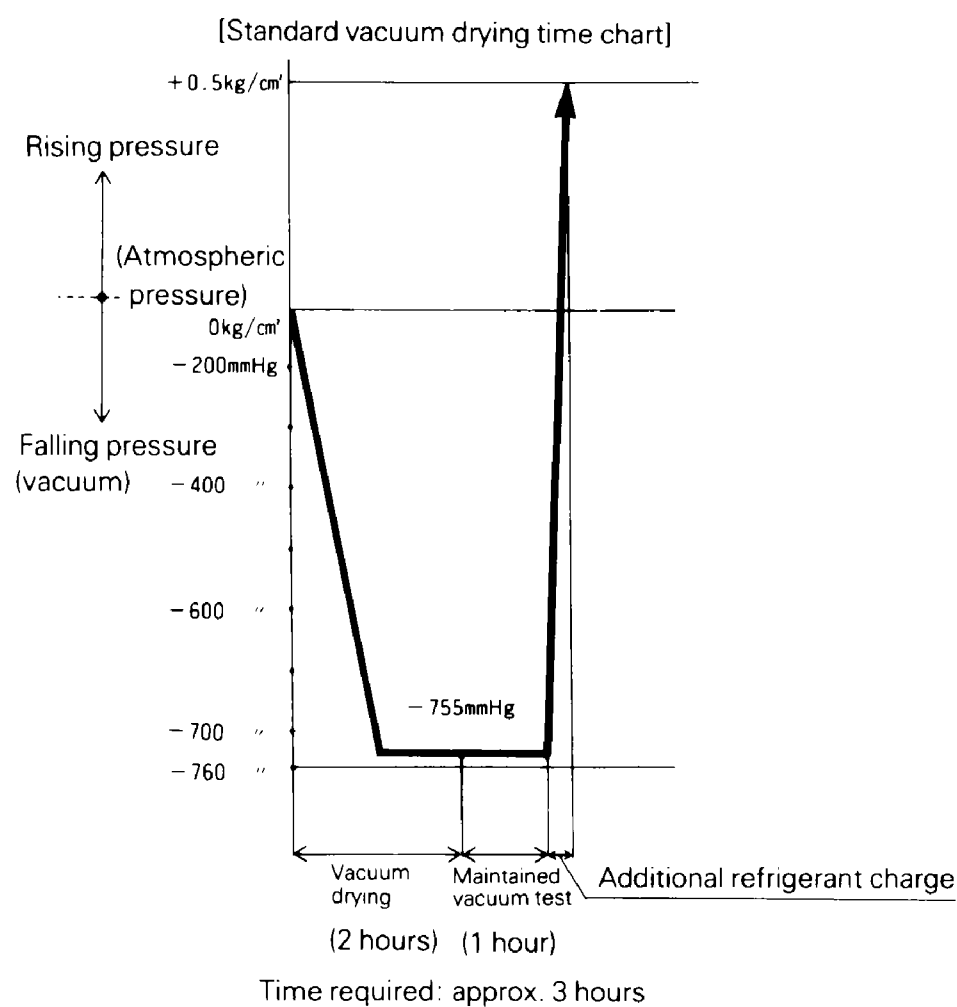

## Special vacuum drying

This vacuum drying method is selected when there is a suspicion that there may be moisture in the pipes.

For example:

- When moisture was discovered during the refrigerant pipe flushing operation
- When there is a risk of condensation forming inside the pipes during periods of heavy rainfall
- When there is a risk of condensation forming inside the pipes due to a long term of works
- When there is a risk that rainwater may have entered the pipes during installation

The special vacuum drying method is the same as the standard method except that nitrogen is introduced into the pipes to break the vacuum on one or more occasions during the course of the operation.

[Operational steps]

- ① Vacuum drying (1st time): 2 hours
  - ② Vacuum breaking (1st time): Use nitrogen to raise pressure to 0.5 kg/cm<sup>2</sup>.  
(Since the nitrogen gas used to break the vacuum is dry nitrogen this process serves only to enhance the overall drying effect of the vacuum drying operation itself.  
However, since the effectiveness of this process is severely impaired by a high moisture level inside the pipes, the utmost care is required during installation to see that water does not enter or form inside the refrigerant pipes.)
  - ③ Vacuum drying (2nd time): Operate the vacuum pump for at least 1 hour.  
(Observations: Degree of vacuum has reached 5 mmHg. If the degree of vacuum has not reached 5 mmHg after 2 hours or more then repeat the operations at ② (vacuum breaking) and ③ (vacuum drying) above.)
  - ④ Carry out maintained vacuum test: 1 hour
  - ⑤ Additional charge of refrigerant
  - ⑥ Open stop valve to the full
- ※ The gas used for the vacuum breaking operation must be nitrogen.  
(The use of oxygen brings a serious risk of explosions)

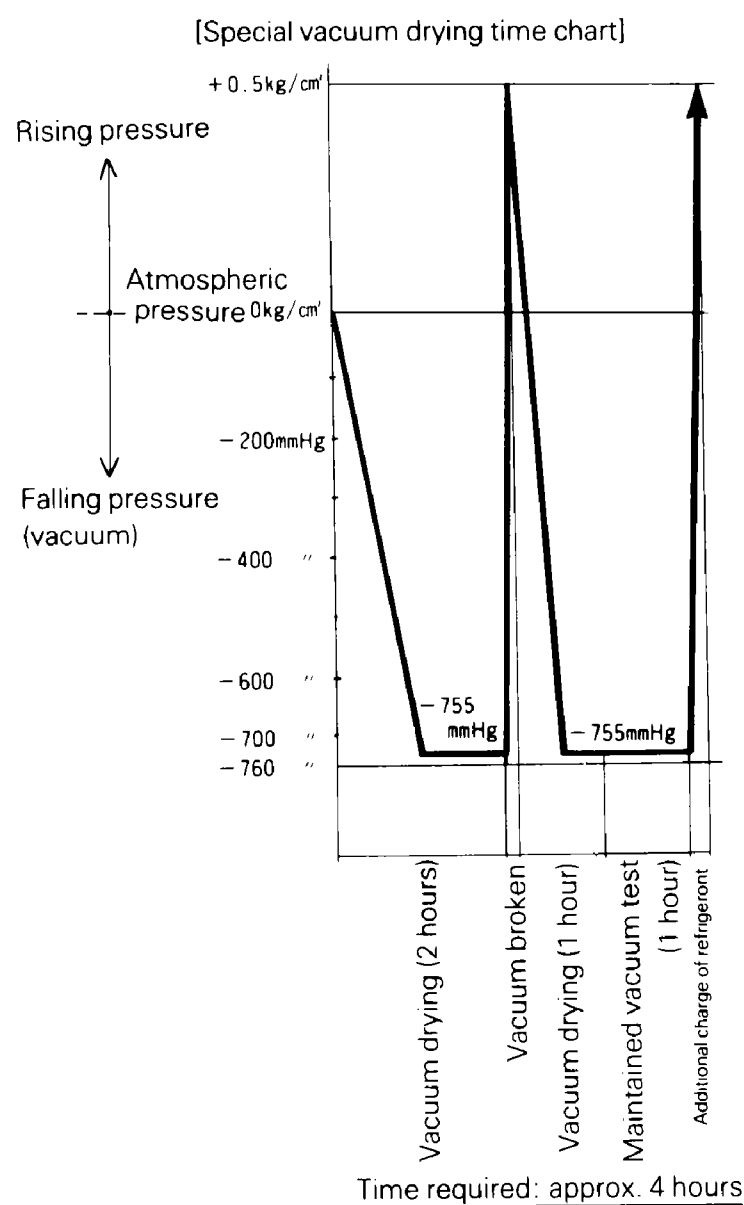

## (11) Additional charge of refrigerant

### ● Operational steps

Use the length of the piping to calculate the amount of refrigerant required



Additional charge of refrigerant

### ● Important points

- ① The results of all calculations must be recorded. (Make a list.)
- ② The refrigerant will need to be additionally charged whenever the distance between the outdoor unit and the most distant indoor unit is more than 10m.
- ③ The additional charging operation should be carried out by input of liquid into the liquid pipes from a charging cylinder following completion of the vacuum drying operation.
- ④ When the additional charging operation cannot be satisfactorily completed use the action of the compressor to complete the additional charging during the test run.

# Inverter Series (RSX(Y)5K)

EXAMPLE OF CONNECTION (When 8 indoor units are connected)			Branch using REFNET joint	Branch using REFNET joint and REFNET header	Branch using REFNET header																																					
Maximum allowable length	Between outdoor and indoor units	Actual pipe length	Pipe length between outdoor and indoor units 100m or less (Example) [8]: a+b+c+d+e+f+g+p ≤ 100m	(Example) [1]: a+b+h ≤ 100m, [7]: a+i+j ≤ 100m	(Example) [8]: a+i ≤ 100m																																					
		Equivalent length	Equivalent pipe length between outdoor and indoor units 125m or less (Assume equivalent pipe length of REFNET joint to be 0.5m, that of REFNET header to be 1m, computation is)																																							
Allowable height length	Between outdoor and indoor units	Difference in height	Difference in height between outdoor unit and indoor unit (H1) 50m or less (40m or less when outdoor unit is located in a lower position)																																							
	Between adjacent indoor units	Difference in height	Difference in height between adjacent indoor units (H2) 15m or less																																							
Allowable length after the branch	Actual pipe length	Pipe length from first refrigerant branch kit (either REFNET joint or REFNET header) to indoor unit 40m or less																																								
		(Example) [8]: b+c+d+e+f+g+p ≤ 40m	(Example) [6]: b+h ≤ 40m, [7]: i+k ≤ 40m	(Example) [8]: i ≤ 40m																																						
Refrigerant branch kit selection			<p><b>How to select REFNET joint</b></p> <ul style="list-style-type: none"> <li>When using REFNET joint at the first branch counted from the outdoor unit side, use KHRJ26K17T. (Example: REFNET joint A)</li> <li>In the case of REFNET joints other than the first branch, select the proper branch kit model based on the total capacity sum (for computation) of the indoor units installed after the first branch using the following table. (For the total capacity, see the item 1 in the section under "COMBINATION" at the beginning.)</li> </ul> <table border="1"> <thead> <tr> <th>Total capacity sum of indoor units</th> <th>Refrigerant branch kit No. to be used</th> </tr> </thead> <tbody> <tr> <td>Less than 100</td> <td>KHRJ26K11T</td> </tr> <tr> <td>100 or more</td> <td>KHRJ26K17T</td> </tr> </tbody> </table>	Total capacity sum of indoor units	Refrigerant branch kit No. to be used	Less than 100	KHRJ26K11T	100 or more	KHRJ26K17T	<p><b>How to select REFNET header</b></p> <ul style="list-style-type: none"> <li>Select the proper branch kit model based on the total capacity sum (for computation) of the indoor units installed after the header using the following table. (For the total capacity, see the item 1 in the section under "COMBINATION" at the beginning.)</li> <li>Branching is impossible between REFNET header and indoor unit.</li> </ul> <table border="1"> <thead> <tr> <th>Total capacity sum of indoor units</th> <th>Refrigerant branch kit No. to be used</th> </tr> </thead> <tbody> <tr> <td>Less than 100</td> <td>KHRJ26K11T (Up to 4 branches)</td> </tr> <tr> <td>100 or more</td> <td>KHRJ26K17T (Up to 8 branches)</td> </tr> </tbody> </table>	Total capacity sum of indoor units	Refrigerant branch kit No. to be used	Less than 100	KHRJ26K11T (Up to 4 branches)	100 or more	KHRJ26K17T (Up to 8 branches)																										
Total capacity sum of indoor units	Refrigerant branch kit No. to be used																																									
Less than 100	KHRJ26K11T																																									
100 or more	KHRJ26K17T																																									
Total capacity sum of indoor units	Refrigerant branch kit No. to be used																																									
Less than 100	KHRJ26K11T (Up to 4 branches)																																									
100 or more	KHRJ26K17T (Up to 8 branches)																																									
Example of downstream indoor units			(Example) In case of REFNET joint C Indoor units [3] + [4] + [5] + [6] + [7] + [8].	(Example) In the case of REFNET joint B Indoor units [7] + [8]. (Example) In the case of REFNET header Indoor units [1] + [2] + [3] + [4] + [5] + [6].	(Example) In the case of REFNET header Indoor units [1] + [2] + [3] + [4] + [5] + [6] + [7] + [8].																																					
Outline of selecting pipe size			<p><b>Between outdoor unit and uppermost stream refrigerant branch kit</b></p> <ul style="list-style-type: none"> <li>Match the pipe size to that connected to outdoor unit.</li> </ul> <p>Pipe size connected to outdoor unit. (Unit:mm)</p> <table border="1"> <thead> <tr> <th rowspan="2">Model name</th> <th colspan="2">Pipe size (Outer diameter X minimum wall thickness)</th> </tr> <tr> <th>Gas pipe</th> <th>Liquid pipe</th> </tr> </thead> <tbody> <tr> <td>RSX(Y)5K</td> <td>φ 19.1X1.0</td> <td>φ 9.5X0.8</td> </tr> </tbody> </table>	Model name	Pipe size (Outer diameter X minimum wall thickness)		Gas pipe	Liquid pipe	RSX(Y)5K	φ 19.1X1.0	φ 9.5X0.8	<p><b>Between two immediately adjacent refrigerant branch kits.</b></p> <ul style="list-style-type: none"> <li>Select the proper pipe size based on the total capacity sum (for computation) of the indoor units connected downstream using the following table. (For the total capacity, see the item in the selection under "COMBINATION" at the beginning.)</li> </ul> <p>(Unit:mm)</p> <table border="1"> <thead> <tr> <th rowspan="2">Total capacity sum of indoor units</th> <th colspan="2">Pipe size (Outer diameter X minimum wall thickness)</th> </tr> <tr> <th>Gas pipe</th> <th>Liquid pipe</th> </tr> </thead> <tbody> <tr> <td>Less than 100</td> <td>φ 15.9X1.0</td> <td>φ 9.5X0.8</td> </tr> <tr> <td>100 or more</td> <td>φ 19.1X1.0</td> <td>φ 9.5X0.8</td> </tr> </tbody> </table>	Total capacity sum of indoor units	Pipe size (Outer diameter X minimum wall thickness)		Gas pipe	Liquid pipe	Less than 100	φ 15.9X1.0	φ 9.5X0.8	100 or more	φ 19.1X1.0	φ 9.5X0.8	<p><b>Between refrigerant branch kit and indoor unit</b></p> <ul style="list-style-type: none"> <li>Pipe size for direct connection to indoor unit must be the same as the connection size of indoor unit.</li> </ul> <p>Connection pipe size of indoor unit. (Unit:mm)</p> <table border="1"> <thead> <tr> <th rowspan="2">Indoor unit capacity sum of indoor units</th> <th colspan="2">Pipe size (Outer diameter X minimum wall thickness)</th> </tr> <tr> <th>Gas pipe</th> <th>Liquid pipe</th> </tr> </thead> <tbody> <tr> <td>20 · 25 · 32 · 40</td> <td>φ 15.9</td> <td>φ 6.4X0.8</td> </tr> <tr> <td>50 · 63 · 80</td> <td>φ 15.9</td> <td>φ 9.5X0.8</td> </tr> <tr> <td>100 · 125</td> <td>φ 19.1</td> <td>φ 9.5X0.8</td> </tr> </tbody> </table>	Indoor unit capacity sum of indoor units	Pipe size (Outer diameter X minimum wall thickness)		Gas pipe	Liquid pipe	20 · 25 · 32 · 40	φ 15.9	φ 6.4X0.8	50 · 63 · 80	φ 15.9	φ 9.5X0.8	100 · 125	φ 19.1	φ 9.5X0.8				
Model name	Pipe size (Outer diameter X minimum wall thickness)																																									
	Gas pipe	Liquid pipe																																								
RSX(Y)5K	φ 19.1X1.0	φ 9.5X0.8																																								
Total capacity sum of indoor units	Pipe size (Outer diameter X minimum wall thickness)																																									
	Gas pipe	Liquid pipe																																								
Less than 100	φ 15.9X1.0	φ 9.5X0.8																																								
100 or more	φ 19.1X1.0	φ 9.5X0.8																																								
Indoor unit capacity sum of indoor units	Pipe size (Outer diameter X minimum wall thickness)																																									
	Gas pipe	Liquid pipe																																								
20 · 25 · 32 · 40	φ 15.9	φ 6.4X0.8																																								
50 · 63 · 80	φ 15.9	φ 9.5X0.8																																								
100 · 125	φ 19.1	φ 9.5X0.8																																								
Outline of how to compute quantity of refrigerant to be charged additionally.			<p>(Example)</p> <table border="1"> <tr> <td>a : φ 9.5X30m</td> <td>e : φ 9.5X 3m</td> <td>i : φ 6.4X 5m</td> <td>m : φ 6.4X 5m</td> </tr> <tr> <td>b : φ 9.5X 5m</td> <td>f : φ 9.5X 2m</td> <td>j : φ 6.4X 5m</td> <td>n : φ 6.4X 5m</td> </tr> <tr> <td>c : φ 9.5X 5m</td> <td>g : φ 9.5X 5m</td> <td>k : φ 6.4X 5m</td> <td>p : φ 6.4X 5m</td> </tr> <tr> <td>d : φ 9.5X 5m</td> <td>h : φ 9.5X 5m</td> <td>l : φ 9.5X 5m</td> <td></td> </tr> </table> $R = \frac{55 \times 0.05}{a+b+c+d+e+f+g} + \frac{40 \times 0.025}{h+i+j+k+l+m+n+p} - 1 = \frac{2.75}{2.8\text{kg}}$	a : φ 9.5X30m	e : φ 9.5X 3m	i : φ 6.4X 5m	m : φ 6.4X 5m	b : φ 9.5X 5m	f : φ 9.5X 2m	j : φ 6.4X 5m	n : φ 6.4X 5m	c : φ 9.5X 5m	g : φ 9.5X 5m	k : φ 6.4X 5m	p : φ 6.4X 5m	d : φ 9.5X 5m	h : φ 9.5X 5m	l : φ 9.5X 5m		<p>(Example)</p> <table border="1"> <tr> <td>a : φ 9.5X60m</td> <td>d : φ 6.4X10m</td> <td>g : φ 6.4X10m</td> <td>j : φ 9.5X10m</td> </tr> <tr> <td>b : φ 9.54X10m</td> <td>e : φ 6.4X20m</td> <td>h : φ 6.4X10m</td> <td>k : φ 6.4X10m</td> </tr> <tr> <td>c : φ 9.5X10m</td> <td>f : φ 6.4X10m</td> <td>i : φ 6.4X10m</td> <td></td> </tr> </table> $R = \frac{70 \times 0.05}{a+b} + \frac{100 \times 0.025}{c+d+e+f+g+h+i+j+k} - 1 = \frac{5.0}{5.0\text{kg}}$	a : φ 9.5X60m	d : φ 6.4X10m	g : φ 6.4X10m	j : φ 9.5X10m	b : φ 9.54X10m	e : φ 6.4X20m	h : φ 6.4X10m	k : φ 6.4X10m	c : φ 9.5X10m	f : φ 6.4X10m	i : φ 6.4X10m		<p>(Example)</p> <table border="1"> <tr> <td>a : φ 9.5X40m</td> <td>d : φ 6.4X10m</td> <td>g : φ 6.4X20m</td> </tr> <tr> <td>b : φ 6.4X10m</td> <td>e : φ 6.4X20m</td> <td>h : φ 6.4X20m</td> </tr> <tr> <td>c : φ 6.4X10m</td> <td>f : φ 6.4X20m</td> <td>i : φ 6.4X20m</td> </tr> </table> $R = \frac{40 \times 0.05}{a} + \frac{150 \times 0.025}{b+c+d+e+f+g} - 1 = \frac{7.5}{8\text{kg}}$	a : φ 9.5X40m	d : φ 6.4X10m	g : φ 6.4X20m	b : φ 6.4X10m	e : φ 6.4X20m	h : φ 6.4X20m	c : φ 6.4X10m	f : φ 6.4X20m	i : φ 6.4X20m
a : φ 9.5X30m	e : φ 9.5X 3m	i : φ 6.4X 5m	m : φ 6.4X 5m																																							
b : φ 9.5X 5m	f : φ 9.5X 2m	j : φ 6.4X 5m	n : φ 6.4X 5m																																							
c : φ 9.5X 5m	g : φ 9.5X 5m	k : φ 6.4X 5m	p : φ 6.4X 5m																																							
d : φ 9.5X 5m	h : φ 9.5X 5m	l : φ 9.5X 5m																																								
a : φ 9.5X60m	d : φ 6.4X10m	g : φ 6.4X10m	j : φ 9.5X10m																																							
b : φ 9.54X10m	e : φ 6.4X20m	h : φ 6.4X10m	k : φ 6.4X10m																																							
c : φ 9.5X10m	f : φ 6.4X10m	i : φ 6.4X10m																																								
a : φ 9.5X40m	d : φ 6.4X10m	g : φ 6.4X20m																																								
b : φ 6.4X10m	e : φ 6.4X20m	h : φ 6.4X20m																																								
c : φ 6.4X10m	f : φ 6.4X20m	i : φ 6.4X20m																																								
<p>Quantity of additional charge R (kg)</p> $R = \left[ \frac{\text{Total length of 9.5mm dia. liquid line}}{\text{Total length of 6.4mm dia. liquid line}} + \frac{\text{Total length of 6.4mm dia. liquid line}}{\text{Total length of 6.4mm dia. liquid line}} \right] \times 0.025 - 1$ <p>•Round off R to one decimal place. •When R is zero or smaller, keep the unit in operation.</p>																																										

Все каталоги и инструкции здесь: <https://sp>

**EXAMPLE OF CONNECTION**

(When 8 indoor units are connected)

**Branch using REFNET joint**

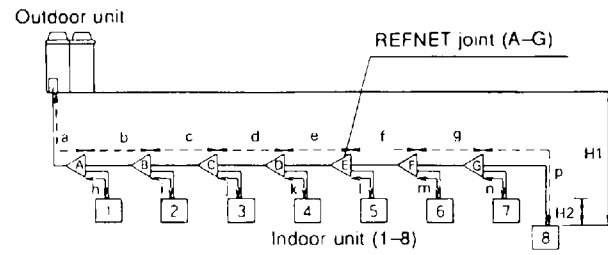

**Branch using REFNET joint and REFNET header**

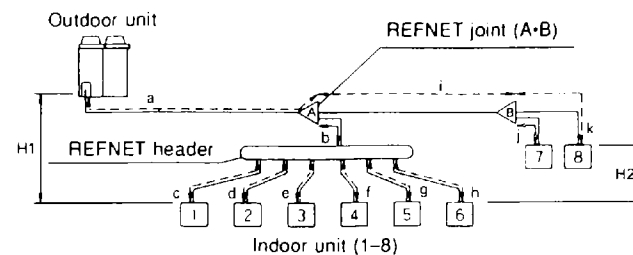

**Branch using REFNET header**

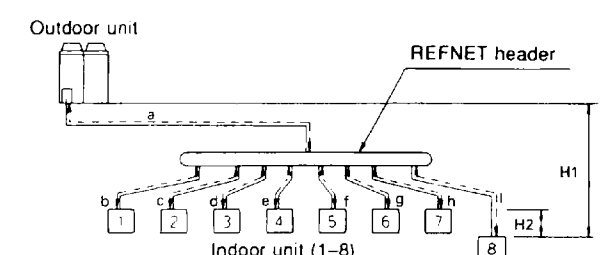

<b>Maximum allowable length</b>	Between outdoor and indoor units	Actual pipe length	Pipe length between outdoor and indoor units 100m or less (Example) ⑧:a+b+c+d+e+f+g+p ≤ 100m	(Example) ①:a+b+h ≤ 100m, ⑦:a+i+j ≤ 100m	(Example) ⑧:a+i ≤ 100m
		Equivalent length	Equivalent pipe length between outdoor and indoor units 125m or less (Assume equivalent pipe length of REFNET joint to be 0.5m, that of REFNET header to be 1m, computation purposes)		
<b>Allowable height length</b>	Between outdoor and indoor units	Difference in height	Difference in height between outdoor and indoor units (H1) 50m or less (40m or less when outdoor unit is located in a lower position)		
	Between adjacent indoor units	Difference in height	Difference in height between adjacent indoor units (H2) 15m or less		

<b>Maximum allowable length after the branch</b>	Actual pipe length	Pipe length from first refrigerant branch kit (either REFNET joint or REFNET header) to indoor unit 40m or less (Example) ⑧:b+c+d+e+f+g+p ≤ 40m	(Example) ⑥:b+h ≤ 40m, ⑦:i+k ≤ 40m	(Example) ⑧:i ≤ 40m
--	--------------------	--	------------------------------------	---------------------

<b>Refrigerant branch kit selection</b>	<p><b>How to select REFNET joint</b></p> <ul style="list-style-type: none"> <li>When using REFNET joint at the first branch counted from the outdoor unit side, use KHRJ26K37T. (Example: REFNET joint A)</li> <li>In the case of REFNET joints other than the first branch, select the proper branch kit model based on the total capacity sum (for computation) of the indoor units installed after the first branch using the following table. (For the total capacity, see the item 1 in the section under "COMBINATION" at the beginning.)</li> </ul>	<p><b>How to select REFNET header</b></p> <ul style="list-style-type: none"> <li>Select the proper branch kit model based on the total capacity sum (for computation) of the indoor units installed after the header using the following table. (For the total capacity, see the item 1 in the section under "COMBINATION" at the beginning.)</li> <li>Branching is impossible between REFNET header and indoor unit.</li> </ul>											
			<table border="1"> <tr> <th>Total capacity sum of indoor units</th> <th>Refrigerant branch kit No. to be used</th> </tr> <tr> <td>Less than 160</td> <td>KHRJ26K18T</td> </tr> <tr> <td>160 or more</td> <td>KHRJ26K37T</td> </tr> </table>	Total capacity sum of indoor units	Refrigerant branch kit No. to be used	Less than 160	KHRJ26K18T	160 or more	KHRJ26K37T	<table border="1"> <tr> <th>Total capacity sum of indoor units</th> <th>Refrigerant branch kit No. to be used</th> </tr> <tr> <td>Less than 160</td> <td>KHRJ26K18H (Up to 6 branches)</td> </tr> <tr> <td>160 or more</td> <td>KHRJ26K37H (Up to 8 branches)</td> </tr> </table>	Total capacity sum of indoor units	Refrigerant branch kit No. to be used	Less than 160
Total capacity sum of indoor units	Refrigerant branch kit No. to be used												
Less than 160	KHRJ26K18T												
160 or more	KHRJ26K37T												
Total capacity sum of indoor units	Refrigerant branch kit No. to be used												
Less than 160	KHRJ26K18H (Up to 6 branches)												
160 or more	KHRJ26K37H (Up to 8 branches)												

<b>Example of downstream indoor units</b>	(Example) In case of REFNET joint C Indoor units ③ + ④ + ⑤ + ⑥ + ⑦ + ⑧ .	(Example) In the case of REFNET joint B Indoor units ⑦ + ⑧ . (Example) In the case of REFNET header Indoor units ① + ② + ③ + ④ + ⑤ + ⑥ .	(Example) In the case of REFNET header Indoor units ① + ② + ③ + ④ + ⑤ + ⑥ + ⑦ + ⑧ .
---	---	--	--

<b>Method of selecting pipe size</b>	<p><b>Between outdoor unit and uppermost stream refrigerant branch kit</b></p> <ul style="list-style-type: none"> <li>Match the pipe size to that connected to outdoor unit.</li> </ul> <p>Pipe size connected to outdoor unit. (Unit:mm)</p> <table border="1"> <tr> <th rowspan="2">Model name</th> <th colspan="2">Pipe size (Outer diameter X minimum wall thickness)</th> </tr> <tr> <th>Gas pipe</th> <th>Liquid pipe</th> </tr> <tr> <td>RSX(Y)8K</td> <td>φ 25.4X1.2</td> <td rowspan="2">φ 12.7X 0.9</td> </tr> <tr> <td>RSX(Y)10K</td> <td>φ 28.6X1.2</td> </tr> </table>	Model name	Pipe size (Outer diameter X minimum wall thickness)		Gas pipe	Liquid pipe	RSX(Y)8K	φ 25.4X1.2	φ 12.7X 0.9	RSX(Y)10K	φ 28.6X1.2	<p><b>Between two immediately adjacent refrigerant branch kits.</b></p> <ul style="list-style-type: none"> <li>Select the proper pipe size based on the total capacity sum (for computation) of the indoor units connected downstream using the following table. (For the total capacity see the item in the selection under "COMBINATION" at the beginning.)</li> </ul> <p>(Unit:mm)</p> <table border="1"> <tr> <th rowspan="2">Total capacity sum of indoor units</th> <th colspan="2">Pipe size (Outer diameter X minimum wall thickness)</th> </tr> <tr> <th>Gas pipe</th> <th>Liquid pipe</th> </tr> <tr> <td>Less than 100</td> <td>φ 15.9X1.0</td> <td rowspan="3">φ 9.5X0.8</td> </tr> <tr> <td>100 or more to 160 (160 excluded)</td> <td>φ 19.1X1.0</td> </tr> <tr> <td>160 or more</td> <td>φ 25.4X1.2</td> </tr> </table>	Total capacity sum of indoor units	Pipe size (Outer diameter X minimum wall thickness)		Gas pipe	Liquid pipe	Less than 100	φ 15.9X1.0	φ 9.5X0.8	100 or more to 160 (160 excluded)	φ 19.1X1.0	160 or more	φ 25.4X1.2	<p><b>Between refrigerant branch kit and indoor unit</b></p> <ul style="list-style-type: none"> <li>Pipe size for direct connection to indoor unit must be the same as the connection size of indoor unit.</li> </ul> <p>Connection pipe size of indoor unit (Unit:mm)</p> <table border="1"> <tr> <th rowspan="2">Indoor unit capacity sum of indoor units</th> <th colspan="2">Pipe size (Outer diameter X minimum wall thickness)</th> </tr> <tr> <th>Gas Pipe</th> <th>Liquid pipe</th> </tr> <tr> <td>20 · 25 · 32 · 40</td> <td>φ 12.7X0.9</td> <td>φ 6.4X0.8</td> </tr> <tr> <td>50 · 63 · 80</td> <td>φ 15.9X1.0</td> <td rowspan="2">φ 9.5X0.8</td> </tr> <tr> <td>100 · 125</td> <td>φ 19.1X1.0</td> </tr> <tr> <td>200</td> <td>φ 25.4X1.2</td> <td>φ 12.7X 0.9</td> </tr> <tr> <td>250</td> <td>φ 28.6 X1.2</td> <td>φ 12.7X 0.9</td> </tr> </table>	Indoor unit capacity sum of indoor units	Pipe size (Outer diameter X minimum wall thickness)		Gas Pipe	Liquid pipe	20 · 25 · 32 · 40	φ 12.7X0.9	φ 6.4X0.8	50 · 63 · 80	φ 15.9X1.0	φ 9.5X0.8	100 · 125	φ 19.1X1.0	200	φ 25.4X1.2	φ 12.7X 0.9	250	φ 28.6 X1.2	φ 12.7X 0.9
	Model name		Pipe size (Outer diameter X minimum wall thickness)																																									
Gas pipe		Liquid pipe																																										
RSX(Y)8K	φ 25.4X1.2	φ 12.7X 0.9																																										
RSX(Y)10K	φ 28.6X1.2																																											
Total capacity sum of indoor units	Pipe size (Outer diameter X minimum wall thickness)																																											
	Gas pipe	Liquid pipe																																										
Less than 100	φ 15.9X1.0	φ 9.5X0.8																																										
100 or more to 160 (160 excluded)	φ 19.1X1.0																																											
160 or more	φ 25.4X1.2																																											
Indoor unit capacity sum of indoor units	Pipe size (Outer diameter X minimum wall thickness)																																											
	Gas Pipe	Liquid pipe																																										
20 · 25 · 32 · 40	φ 12.7X0.9	φ 6.4X0.8																																										
50 · 63 · 80	φ 15.9X1.0	φ 9.5X0.8																																										
100 · 125	φ 19.1X1.0																																											
200	φ 25.4X1.2	φ 12.7X 0.9																																										
250	φ 28.6 X1.2	φ 12.7X 0.9																																										

<b>Method of how to compute quantity of refrigerant to be charged normally.</b>	<p>Quantity of additional charge R (kg)</p> <p>Total length of 12.7mm dia. liquid line × 0.1 + Total length of 9.5mm dia. liquid line × 0.05 + Total length of 6.4mm dia. liquid line × 0.025 - 2</p> <p>Round off R to one decimal place. When R is zero or smaller, keep the unit in operation.</p>	<p>(Example)</p> <p>a: φ 12.7X30m e: φ 9.5X 3m i: φ 6.4X 5m m: φ 6.4X 5m                  b: φ 12.7X 5m f: φ 9.5X 2m j: φ 6.4X 5m n: φ 6.4X 5m                  c: φ 12.7X 5m g: φ 9.5X 5m k: φ 6.4X 5m p: φ 6.4X 5m                  d: φ 12.7X 5m h: φ 9.5X 5m l: φ 9.5X 5m</p> <p>R = <math>\frac{45 \times 0.1}{a+b+c+d} + \frac{20 \times 0.05}{e+f+g+h+i} + \frac{30 \times 0.025}{i+j+k+l+m+n+p} - 2 = 4.25</math> [4.3kg]</p>	<p>(Example)</p> <p>a: φ 12.7X30m d: φ 6.4X10m g: φ 6.4X10m j: φ 9.5X10m                  b: φ 12.7X10m e: φ 6.4X10m h: φ 6.4X20m k: φ 6.4X 9m                  c: φ 9.5X10m f: φ 6.4X10m i: φ 9.5X10m</p> <p>R = <math>\frac{40 \times 0.1}{a+b} + \frac{30 \times 0.05}{c+i+j} + \frac{69 \times 0.025}{d+e+f+g+h+k} - 2 = 5.225</math> [5.2kg]</p>	<p>(Example)</p> <p>a: φ 12.7X40m d: φ 6.4X10m g: φ 6.4X20m                  b: φ 9.5X20m e: φ 6.4X20m h: φ 6.4X20m                  c: φ 9.5X10m f: φ 6.4X23m i: φ 6.4X30m</p> <p>R = <math>\frac{40 \times 0.1}{a} + \frac{30 \times 0.05}{b+c} + \frac{123 \times 0.025}{d+e+f+g+h+i} - 2 = 6.575</math> [6.6kg]</p>
---	---	---	---	---

Все каталоги и инструкции здесь:

## (12) Field settings

- **Work procedure**

Indicate the person responsible for settings and setting method on the contract drawings.



The appointed person makes the settings.

### 1) Checking settings

Check settings and setting procedure are marked on the contract drawings and system diagrams.

NOTE: Setting procedure will vary with equipment model. For details, refer to the installation manual attached with the unit.

- **For Inverter K Series**

Make settings after activating power to the system and while both the indoor and outdoor units are stopped.

- **For other than Inverter K Series (Inverter G & H Series, Heat recovery Series, etc.)**

Settings must be made before power is activated. Changes made after power has been turned ON will be ignored.

## 2) Settings

### Example For Inverter K Series

- Field settings made with the remote controller

With the Inverter K Series, all field settings are made from the remote controller of the indoor unit. A description of each setting is provided on the below table. For details on how to make settings, refer to the operation manual and/or installation manual of the unit.

- Description of settings and code numbers

Mode No. Note 2	First Code No.	Setting Contents	Second Code No.(Note 3)								
			01		02		03		04		
VRV system indoor unit settings	10(20)	Filter contamination heavy/light (Setting for display time to clean air filter) (Sets display time to clean air filter to half when there is heavy filter contamination.)	Super long life filter	Light	Approx. 10,000 hrs.	Heavy	Approx. 5,000 hrs.	_____	_____		
			Long life filter		Approx. 2,500 hrs.		Approx. 1,250 hrs.				
			Standard filter		Approx. 200 hrs.		Approx. 100 hrs.				
		1	Long life filter type (FXYC only, 01 indicates long life)	Long life filter	Super long life filter	_____	Soot filter				
	2	Thermostat sensor in remote controller	Use	No use	_____	_____					
	3	Display time to clean air filter calculation (Set when filter sign is not to be displayed.)	Display	No display	_____	_____					
	12(22)	0	Optional accessories output selection (field selection of output for adaptor for wiring)	Indoor unit turned ON by thermostat	_____	Operation output	Malfunction output				
		1	ON/OFF input from outside (Set when ON/OFF is to be controlled from outside.)	Forced OFF	ON/OFF control	External protection device	_____				
		2	Thermostat differential changeover (Set when remote sensor is to be used.) FXYC, FXYE, FXYF, FXYK, FXYH only	1°C	0.5°C	_____	_____				
		3	OFF by thermostat fan speed	LL	Set fan speed	_____	_____				
		4	Automatic mode differential (automatic temperature differential setting for VRV system heat recovery series cool/heat)	01:0	02:1	03:2	04:3	05:4	06:5	07:6	08:7
		5	Power failure automatic reset	Not equipped	Equipped	_____	_____				
	13(23)	0	High air outlet velocity (Set when installed in place with ceiling higher than 2.7 m.) FXYF only	N	H	_____	_____				
1		Selection of air flow direction (Set when a blocking pad kit has been installed.) FXYF only	F (4 directions)	T (3 directions)	W (2 directions)	_____					
2		Horizontal air discharge	Equipped	Not equipped	_____	_____					
3		Air flow direction adjustment (Set at installation of decoration panel.) FXYK only	Equipped	Not equipped	_____	_____					
4		Field set air flow position setting	Draft prevention	Standard	Ceiling Soiling prevention	_____					
5		Field set fan speed selection (fan speed control by air discharge outlet for phase control)	Standard	Optional accessory 1	Optional accessory 2	_____					
6		Static pressure selection (used for setting static pressure of ducts, etc.)	Standard	High static pressure	Low static pressure	_____					
15(25)	1	Thermostat OFF excess humidity	Not equipped	Equipped	_____	_____					
	3	Drain pump humidifier interlock selection	Not equipped	Equipped	_____	_____					
	4	Sets whether filter sign is to be output by time or by input.	Time addition	Input	_____	_____					
	5	Field set selection for individual ventilation setting by remote controller	Not equipped	Equipped	_____	_____					
	6	Field set selection for individual ventilation setting by remote controller	Not equipped	Equipped	_____	_____					

For HRV settings, see the proper documents for HRV.



# Setting Modes

The three setting modes are as follows:

- **Setting mode 1** .....Mode for selecting cool/heat setting method, and whether or not to use low noise operation and sequential start.  
(H1P off)
- **Setting mode 2** .....Mode for changing operating status and setting addresses; used primarily for service.  
(H1P on)
- **Monitor mode** .....Mode for checking setting made in the setting modes, number of connected units, etc.  
(H1P flickers)

The flow of the setting modes is as follows. (See the following pages for details.)

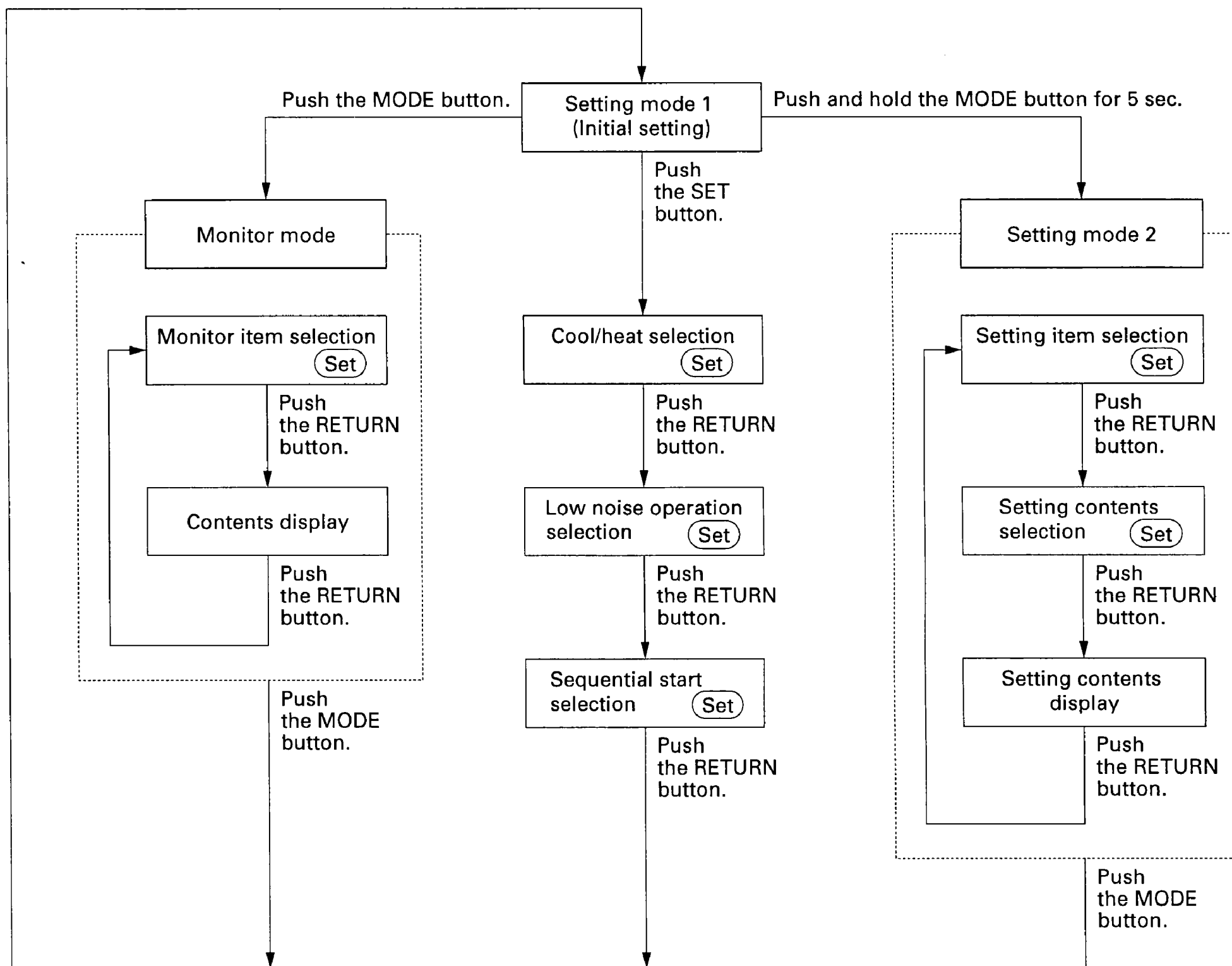

- You can make your selections with the SET button. (Set)

If you become unsure of how to proceed, push the MODE button and return to setting mode 1.

☆ You don't have to perform power supply reset after changing settings in setting mode 1 (including [SS1] cool/heat selection switch on the outdoor unit PC board) and setting mode 2.

# ① Setting Mode 1

Cool/heat selection setting (SS1) If carried out from the indoor unit remote controller: If carried out from the cool/heat selector:

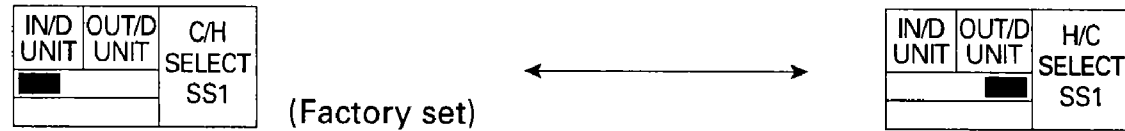

MODE	TEST	C/H SELECT			L.N.O.P.	SEQ. START
		IND	MASTER	SLAVE		
H1P	H2P	H3P	H4P	H5P	H6P	H7P

The factory settings are:

Individual (C/H SELECT), OFF (L.N.O.P.), ON (SEQ. START)

You can change the cool/heat selection permission, low noise and sequential start settings by pushing the SET switch.

To skip settings you don't want to change, push the RETURN switch and go to the next setting.

Change cool/heat selection to MASTER.

An optional adaptor for outside control of outdoor units is required if you have set cool/heat selection to MASTER or SLAVE.

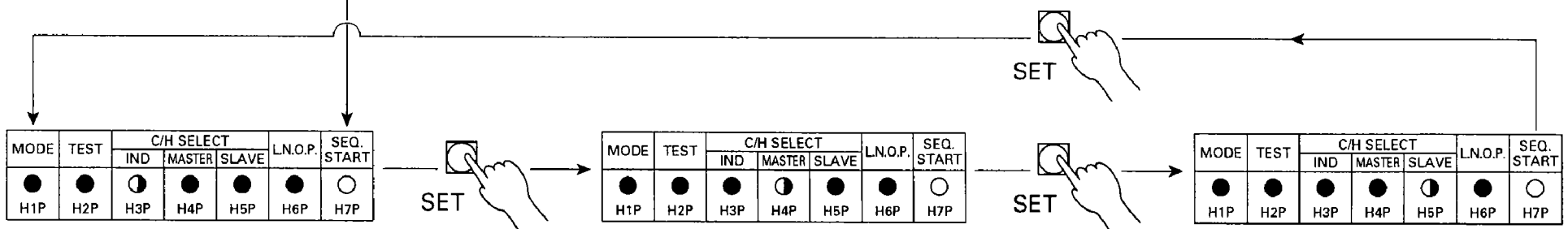

Change low noise operation to "ON".

External control adaptor for outdoor unit is required if low noise operation is set to "ON".

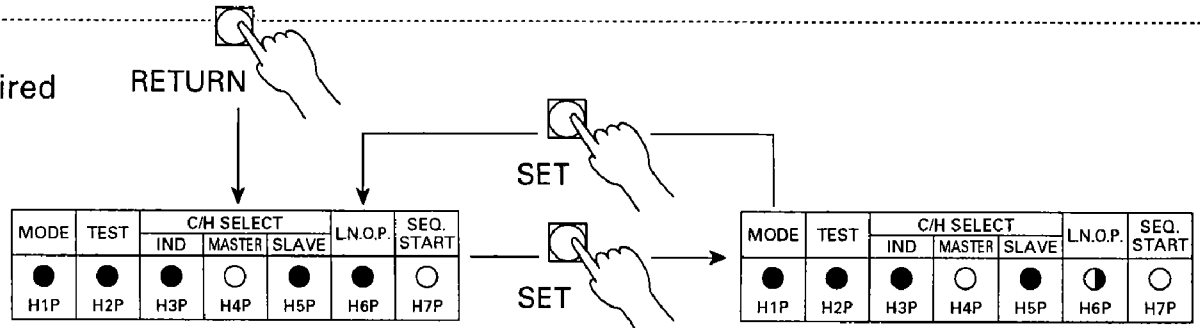

Change sequential start to "OFF".

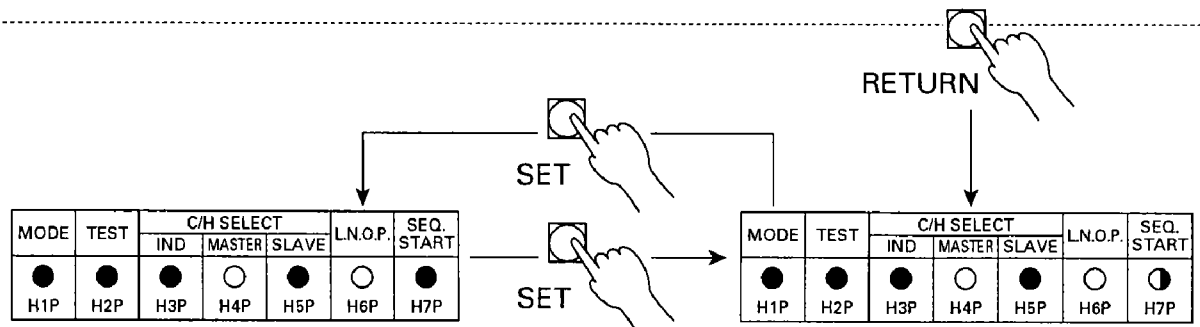

Setting complete

GROUP MASTER (cool/heat selection), ON (low noise), OFF (sequential start)

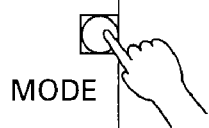
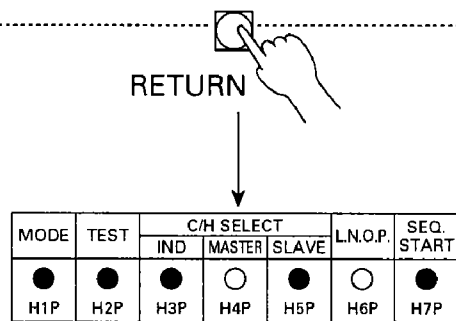

Monitor mode

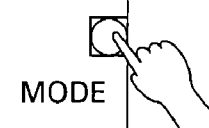

Push and hold for 5 sec.

Setting mode 2

NOTE: 1. RSXY5K is completed by low noise setting.

2. External control adaptor for outdoor unit is required if cool/heat selection set to MASTER or SLAVE, or if low noise operation is set to ON.

## ② Setting Mode 2

To enter setting mode 2 from setting mode 1 (normal), you must push and hold the MODE button (BS1) for 5 seconds. (Setting mode 2 cannot be entered while still making settings in setting mode 1.)

### Setting procedure

① Push the SET button and match with the setting item (LED display). (All 10 settings)



② Push the RETURN button (BS3) and the present settings flicker (LED display).



③ Push the SET button (BS2) and match with each setting (LED flicker display).



④ Push the RETURN button (BS3) and enter the settings.



⑤ Push the RETURN button (BS3) and return to the initial status.

Note: ● If you become unsure of how to proceed, push the MODE button (BS1) and return to setting mode 1.

● The initial status of setting mode 2 is the status of setting item No. 1 in mode 2.

☆1 ... Cannot be set with RSXY5K.

### Settings

	Setting item	Description	LED display							LED display													
			H1P	H2P	H3P	H4P	H5P	H6P	H7P	H1P	H2P	H3P	H4P	H5P	H6P	H7P							
1	EMG ☆1	Emergency operation when malfunction occurs	○	●	●	●	●	●	●	Emergency operation (Runs only by standard compressor)	○	●	●	●	○	●	Normal operation	○	●	●	●	●	○
2	Cool/heat group address	Address for cool/heat group operation	○	●	●	●	●	○	○	Address 0	○	●	●	●	●	●	Binary number 1 (6 digits)	○	●	●	●	○	○
										2	○	●	●	●	○	●	31	○	●	○	○	○	○
3	Low noise / demand address	Address for low noise / demand group operation	○	●	●	●	○	○	○	Address 0	○	●	●	●	●	●	Binary number 1 (6 digits)	○	●	●	●	○	○
										2	○	●	●	●	○	●	31	○	●	○	○	○	○
4	Forced fan switch	Fan of stopped indoor unit turns	○	●	●	○	○	○	○	Forced fan operation (H tap)	○	●	●	●	○	●	Normal operation	○	●	●	●	○	○
5	Indoor unit forced operation	Allows operation of indoor unit from outdoor unit	○	●	●	○	○	○	○	Indoor unit forced operation	○	●	●	●	○	●	Normal operation	○	●	●	●	○	○
6	Frequency fix	Fixes the frequency of the inverter compressor 5HP--68Hz 8.10HP--86Hz+ON	○	●	●	○	○	○	○	Frequency fix	○	●	●	●	○	●	Normal operation	○	●	●	●	○	○
7	Te setting	Low pressure setting for cooling	○	●	○	○	○	○	○	High	○	●	●	○	●	●	Normal (factory set)	○	●	●	●	○	○
										Low	○	●	●	●	○	○							
8	Tc setting	High pressure setting for heating	○	●	○	○	○	○	○														
9	Defrost setting	Temperature setting for defrost	○	●	○	○	○	○	○	Quick defrost	○	●	●	○	●	●	Normal (factory set)	○	●	●	●	○	○
										Slow defrost	○	●	●	●	○	○							
10	Not used	Airnet address	○	●	○	○	○	○	○	Address 0	○	●	●	●	●	●	Binary number 1 (6 digits)	○	●	●	●	○	○
										2	○	●	●	○	○	○	31	○	○	○	○	○	○
										63	○	○	○	○	○	○							

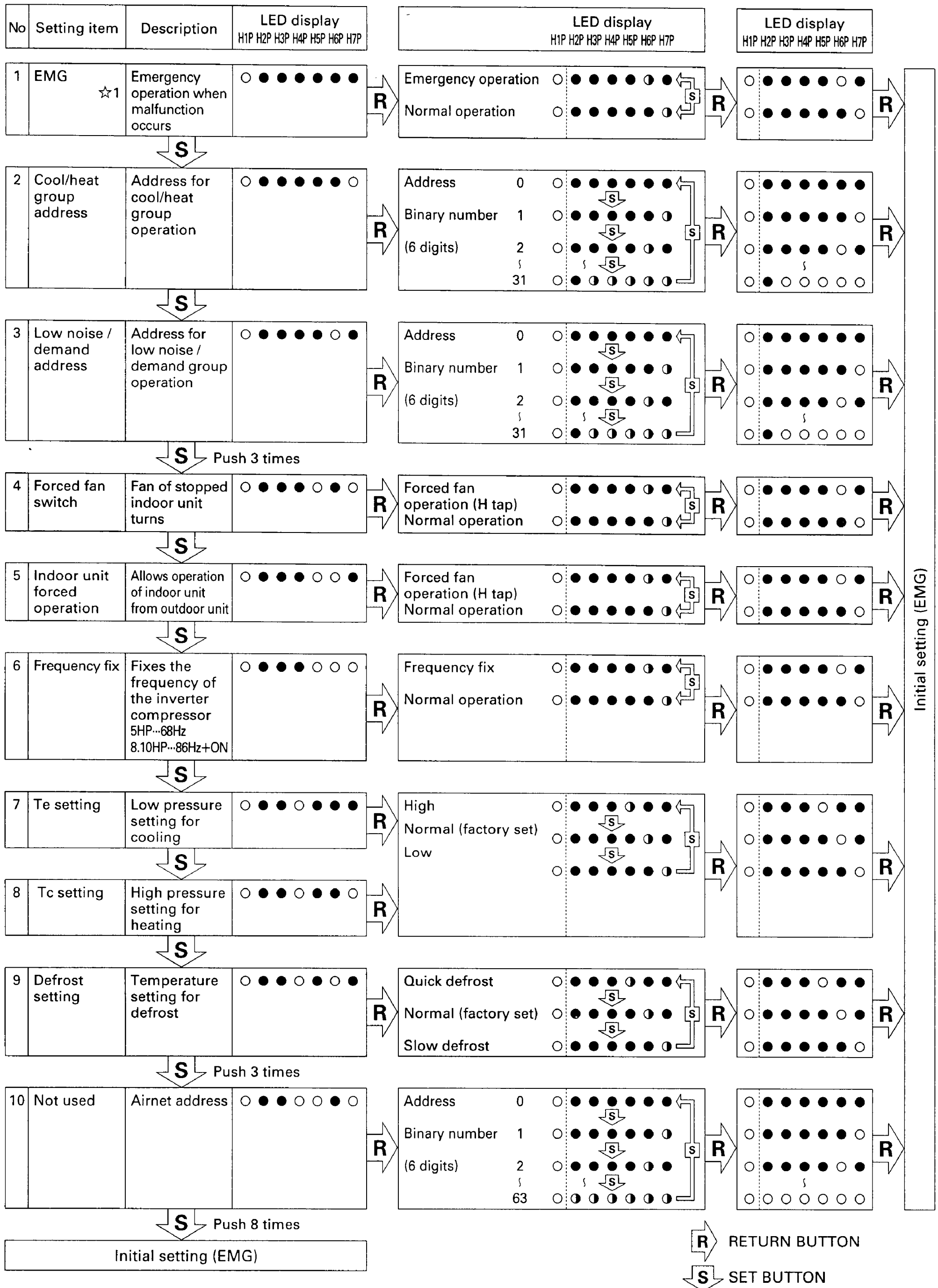

### ③ Monitor Mode

MODE	TEST	C/H SELECT			LN.O.P.	SEQ. START
		IND	MASTER	SLAVE		
● H1P	● H2P	○ H3P	● H4P	● H5P	● H6P	○ H7P

To enter the monitor mode, push the MODE button when in setting mode 1.

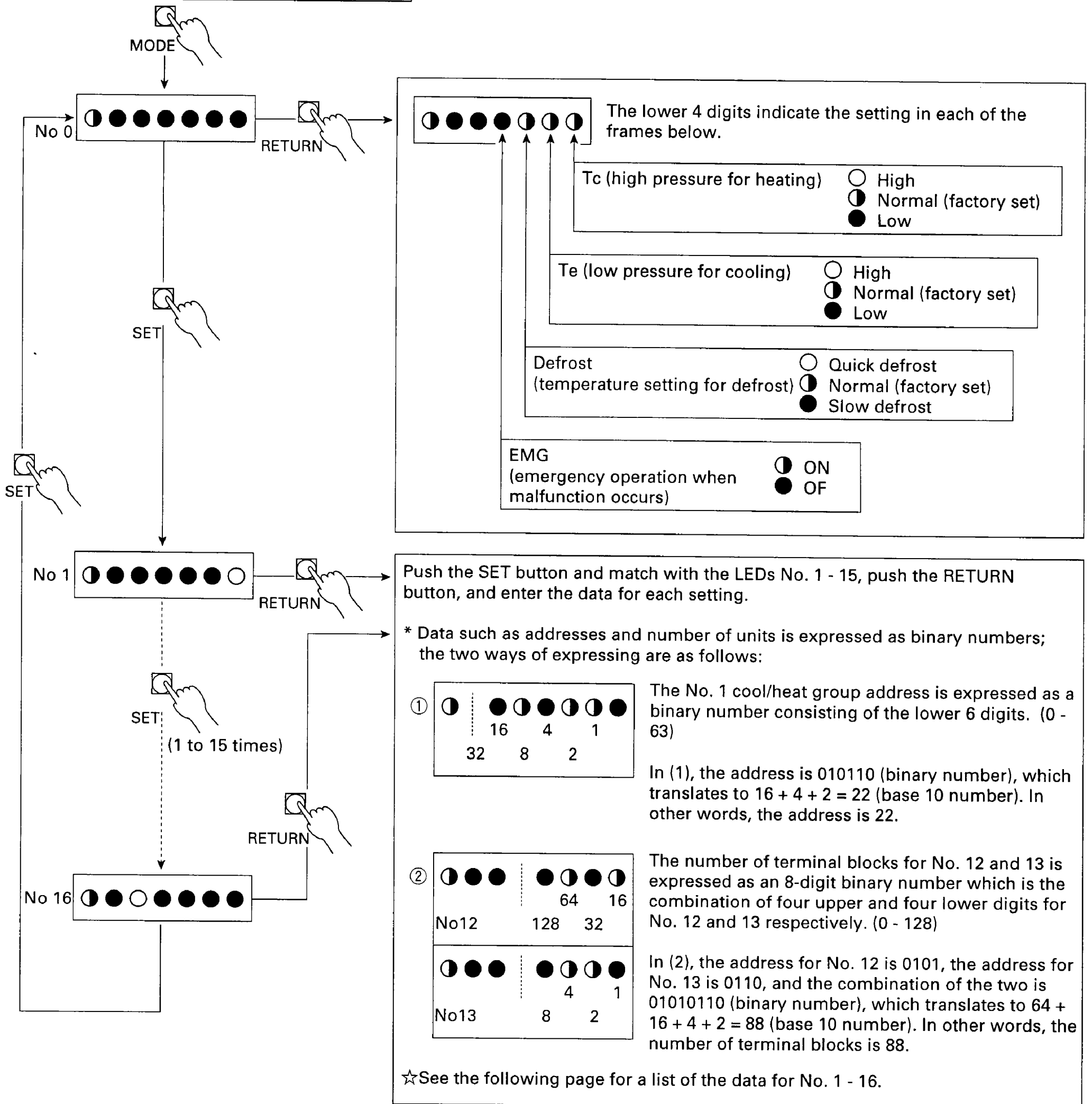

☆ After making sure the data is correct, push the RETURN button and return to No. 0, or push the MODE button and return to setting mode 1.

#### ④ Monitor Mode Data

Mode No.	LED	Data	Display method	Size (binary number)
No 1	● ● ● ● ● ● ○	Cool/heat group address	0 ~ 31	Lower 6 digits
No 2	● ● ● ● ● ○ ●	Low noise / demand address	0 ~ 31	Lower 6 digits
No 3	● ● ● ● ● ○ ○	Not used		
No 4	● ● ● ● ○ ● ●	Not used	0 ~ 63	Lower 6 digits
No 5	● ● ● ● ○ ● ○	Number of connected units	0 ~ 63 units	Lower 6 digits
No 6	● ● ● ● ○ ○ ●	Number of connected BS units	0 ~ 63 units	Lower 6 digits
No 7	● ● ● ● ○ ○ ○	Number of connected zone units (excluding outdoor and BS units)	0 ~ 63 units	Lower 6 digits
No 8	● ● ● ○ ● ● ●	Number of outdoor units	0 ~ 63 units	Lower 6 digits
No 9	● ● ● ○ ● ● ○	Number of BS units	0 ~ 128 units	Lower 4 digits, upper
No 10	● ● ● ○ ● ○ ●	Number of BS units	0 ~ 128 units	Lower 4 digits, lower
No 11	● ● ● ○ ● ○ ○	Number of zone units (excluding outdoor and BS units)	0 ~ 63 units	Lower 6 digits
No 12	● ● ● ○ ○ ● ●	Number of terminal blocks	0 ~ 128 units	Lower 4 digits, upper
No 13	● ● ● ○ ○ ● ○	Number of terminal blocks	0 ~ 128 units	Lower 4 digits, lower
No 14	● ● ● ○ ○ ○ ●	Not used		
No 15	● ● ● ○ ○ ○ ○	Not used		
No 16	● ● ○ ● ● ● ●	Not used		

## (13) Test run adjustment

### 1) Procedure and essential points

The order of the test run operations is extremely important and they should be carried out in accordance with the following principles:

1 Checks to be carried out before switching the power on.

(It is assumed that the vacuum drying operation has been completed.)

Check for incorrectly laid power cables and loose screws.



Check for incorrectly laid control cables and loose screws.



Additional charge of refrigerant when length of refrigerant piping exceeds 10m.



Miscellaneous checks :

- Assembly of indoor and outdoor units
- Presence or absence of trap on gas pipe side
- Pipe size
- Presence or absence of thermal insulation

Open gas line stop valve to the full.



Open liquid line stop valve to the full.



Measure insulation.

● Use a 500V insulation tester.  
● Do not use a insulation tester between indoor and outdoor units or between indoor unit and remote controller. (Because they are low voltage circuit)

2 Switch on the main power supply

Switch on the outdoor units



Set each of the setting switches for various modes.



Switch on the indoor units.

Switch on 6 hours before the system starts operating (To energize the crank case heater).

### 3 Operation checks

Put into test run mode.

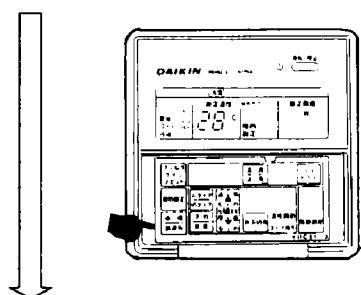

• VRV System Inverter K Series  
Pushing the test run button switches the thermostat on for 30 minutes.

Set the operating mode to "Cooling".

Reason: To prevent liquid back

Momentary operation (5 seconds)

Reoperate air conditioning for further 3 minutes.

Normal running

• Operate the indoor units one by one to check the way in which they correspond to the outdoor units. (There should be a reasonable difference in temperature between the suction air and the discharged air.)  
• Check that the outdoor fan is operating correctly.

(Measurements to be taken)

#### 1. Indoor unit temperature measurements

- 1) Cooling { Temperature of suction air  
Temperature of discharge air
- 2) Heating { Temperature of suction air  
Temperature of discharge air

#### 2. Outdoor unit

- 1) Resistance of insulation
- 2) Voltage and current
- 3) Discharge pressure and suction pressure
- 4) Temperature of discharge pipes and suction pipes
- 5) Temperature of suction air and temperature of discharge air
- 6) Frequency of compressor

The result of each measurement should be written down in on a test run inspection sheet for each operational indoor unit.

### 4 Hand over

When the test run has been completed then you should explain to the customer how to operate the system.



## (14) Caution for refrigerant leaks

### Points to note in connection with refrigerant leaks

#### Introduction

The **VRV** SYSTEM, like most other air conditioning systems, uses "R-22" as its refrigerant. "R-22" itself is an entirely safe non-toxic, non-combustible refrigerant but care must nevertheless be taken to ensure that the air conditioning facilities are installed in a room which is sufficiently large not to exceed the maximum concentration level of refrigerant gas in the unlikely event of a major leak in the system and this in accordance to the local applicable regulations and standard.

#### \*Maximum concentration level

The maximum charge of refrigerant and the calculation of the maximum concentration of refrigerant is directly related to the humanly occupied space in to which it could leak.

The unit of measurement of the concentration is kg/m<sup>3</sup> (the weight in kg of refrigerant gas in 1m<sup>3</sup> volume of the occupied space) Compliance to the local applicable regulations & standards for the max. allowable concentration level is required.

In Japan the maximum allowed concentration level of refrigerant in a humanly occupied space for R22 is limited to : 0.30kg/m<sup>3</sup>.

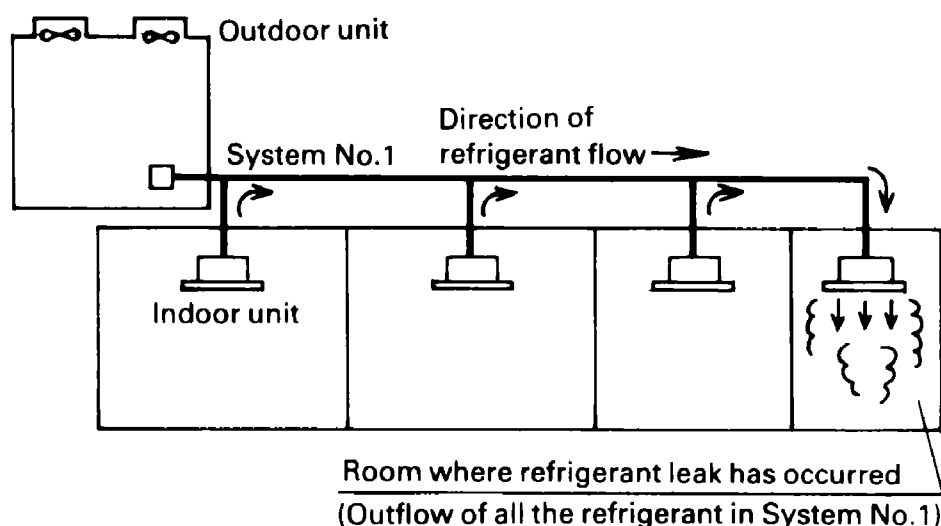

#### Procedure for checking dangerous concentration

Check the maximum concentration level in accordance with steps [1]-[4] below and take whatever action is necessary to comply.

#### [1] Calculate the amount of refrigerant (kg) charged to each system separately.

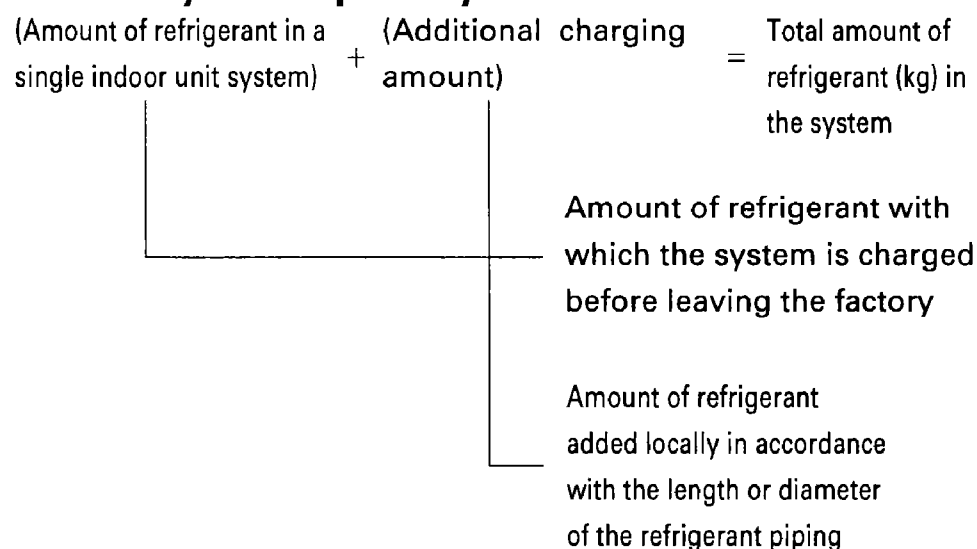

#### Note

Where a single refrigerant facility is divided into 2 entirely independent refrigerant systems then use the amounts of refrigerant with which each separate system is charged.

#### [2] Calculate the smallest room volume (m<sup>3</sup>)

In a case like the following calculate the volume of (a), (b) as a single room or as the smallest room.

(a) Where there are no smaller room divisions

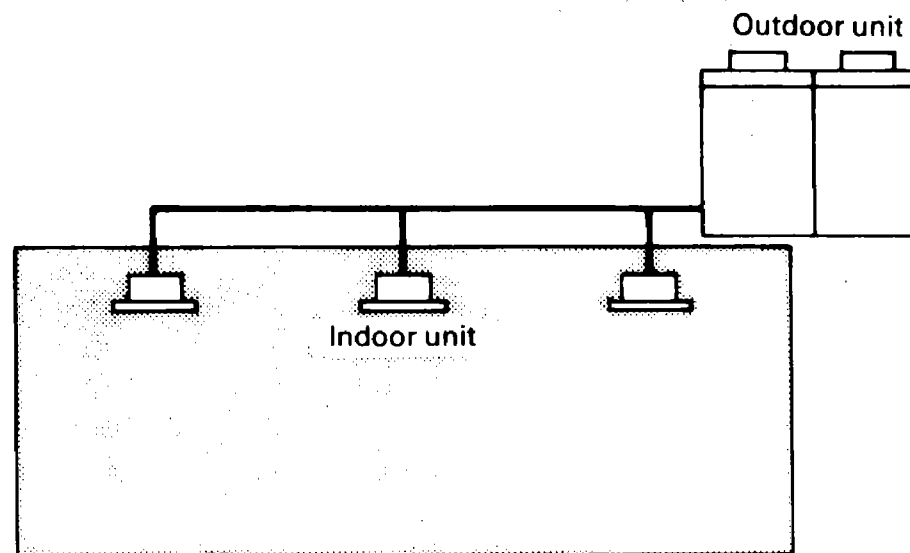

(b) Where there is a room division but there is an opening between the rooms sufficiently large to permit a free flow of air back and forth.

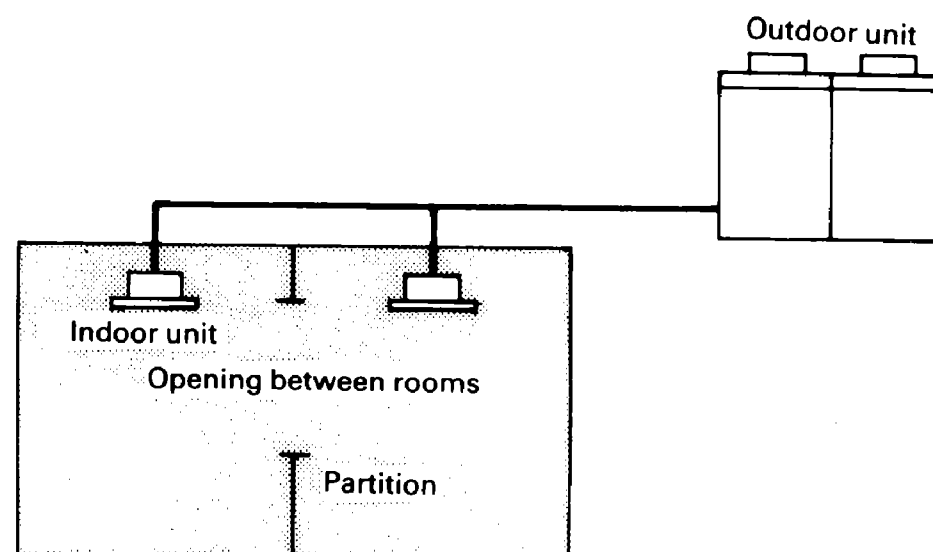

(Where there is an opening without a door or where there are openings above and below the door which are each equivalent in size to 0.15% or more of the floor area.)

#### [3] Calculate the refrigerant density using the results of the calculations in steps [1] and [2] above.

Total volume of refrigerant in the refrigerant system  
 Size (m<sup>3</sup>) of smallest room in which there is an indoor unit installed

$$\frac{\text{Total volume of refrigerant in the refrigerant system}}{\text{Size (m}^3\text{) of smallest room in which there is an indoor unit installed}} \leq \text{Dangerous concentration (kg/m}^3\text{)}$$

If the result of the above calculation exceeds the dangerous concentration level then make similar calculations for the second then third smallest room and so on until the result falls short of the dangerous concentration level.

#### [4] Dealing with situations where the result exceeds the maximum concentration level.

Where the installation of a facility results in a concentration in excess of the maximum concentration level then it will be necessary to revise the system design. Please consult your Daikin supplier.

**[5] Dealing with situations where the result exceeds the dangerous concentration level.**

Where the installation of a facility results in a concentration in excess of the dangerous concentration level then it may be necessary to revise the system design to some extent or else take one of the following courses of action.

**Action 1 : Making openings which will allow the air to flow freely into the room.**

Make openings above and below the door which are each equivalent in size to 0.15% or more of the floor area or make a doorless opening.

**Action 2 : Fit a mechanical ventilator linked to a gas leak detection alarm device.**

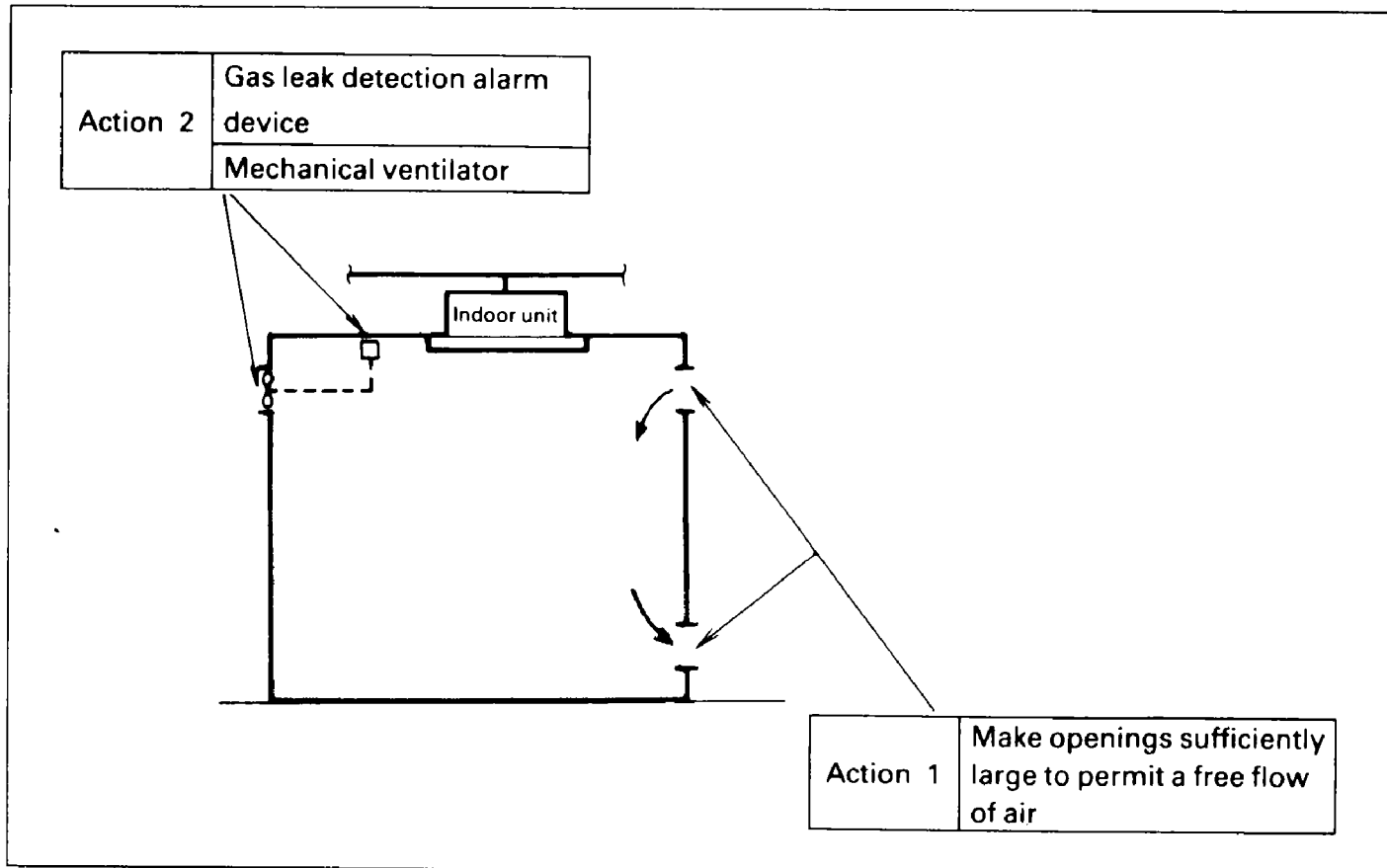

## (15) Hand over to customer

### • Operational steps

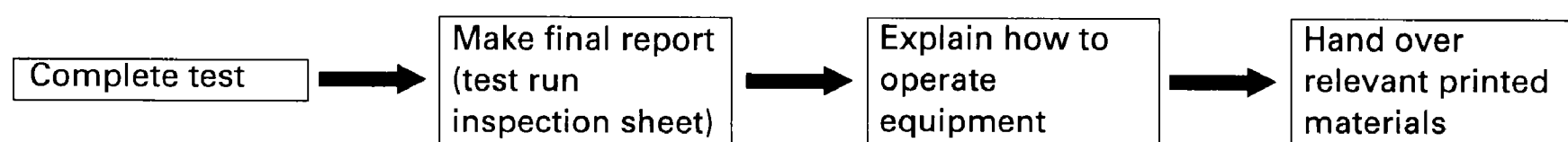

### 1) Important points

- The measurements taken during the test run should be recorded and kept on a test run inspection sheet.
- Do not forget to record the length of the refrigerant piping and the refrigerant additional charging volume on the plate on the back of the outdoor unit external notice board, as this information will be required for servicing the system.
- Explain to the customer how to operate the equipment and let him try it.
- Assemble all the relevant diagrams and other printed matter which is required to operate the system and hand it all over to the customer (on the spot) and tell him to keep it.

List of equipment which has been delivered

Contract drawings

It is essential to prepare a control wiring diagram which clarifies the refrigerant system and the control system.

1 set of operation manuals

Names of those responsible for the work (emergency contact address)

Equipment guarantees.

- Make the service contact address clear.

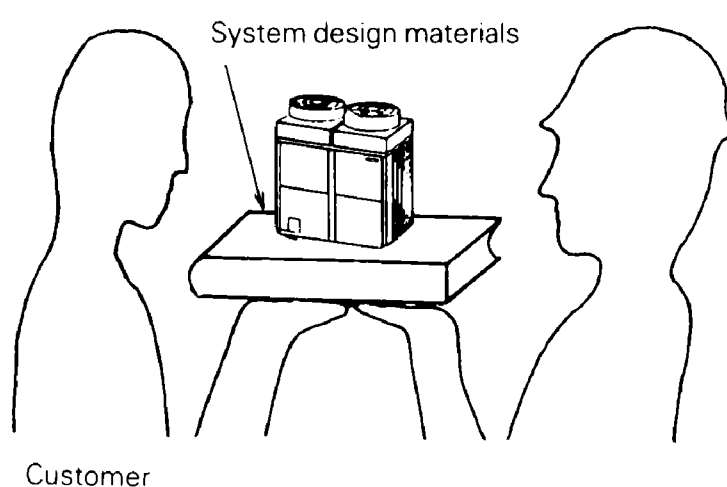

### 3. Bad examples and good examples in installation

#### Example 1: Signal interference due to use of multiple core cable (all model)

##### ■ Situation

Although for the purposes of group control there are only 2 units per group there are transmission malfunctions between the indoor units and the remote controller and the remote controller's address display is showing non-existent addresses such as 13 or 15.

##### ■ Source of problem and remedial action

Multiple core cable has been used for at least part of the interconnecting wiring between the remote controller and the indoor units.

This has resulted in signal interference leading to a transmission malfunction.

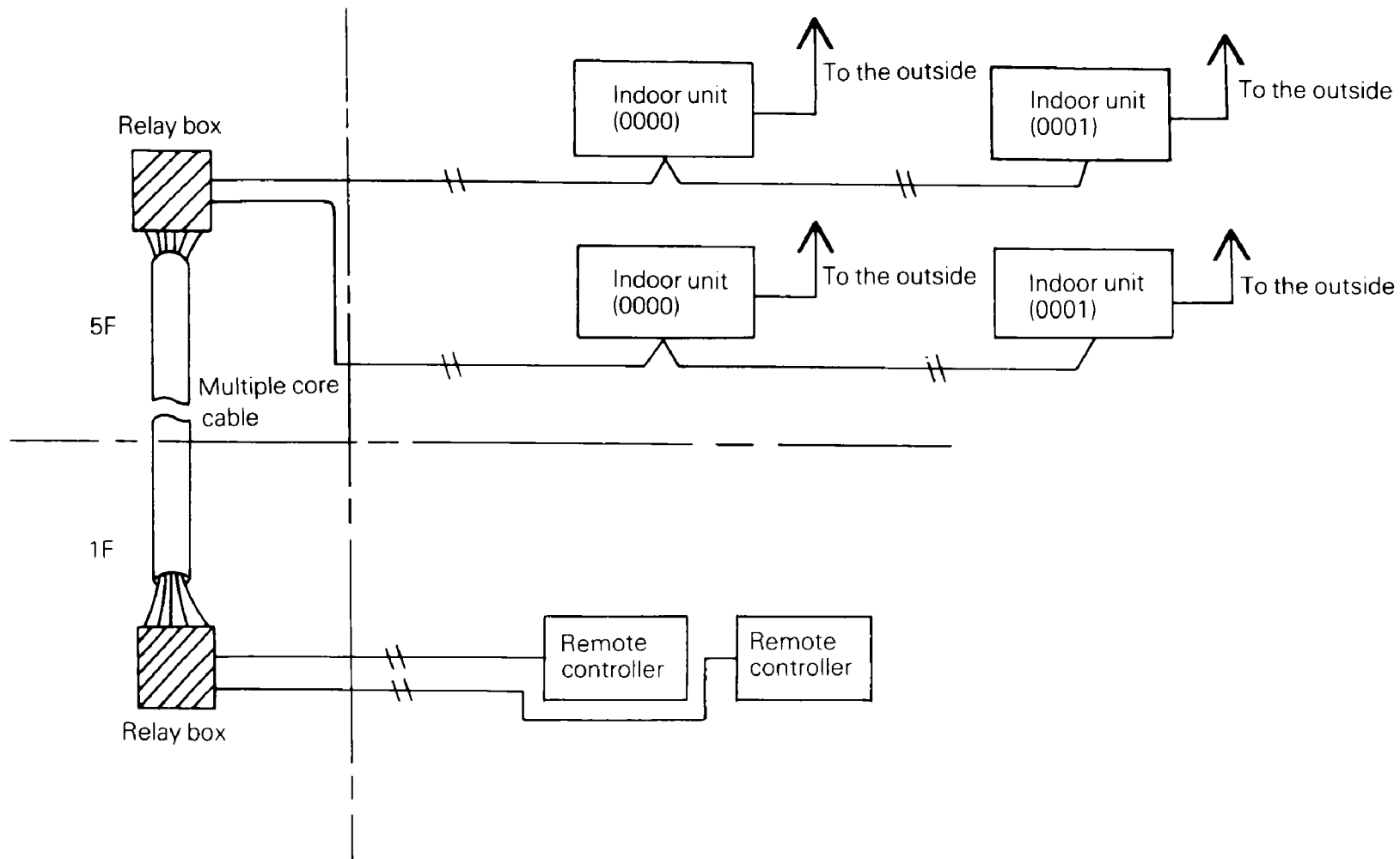

The multiple core cable was replaced by twin core cable and the fault disappeared.

##### ■ Main points

- Although twin core cable had been run from each unit, multiple core cable was used on the way.
- In schools, etc., because remote controllers are often installed in a single first floor control room, it is easier to use a multi-core cable.
- Signal interference can result in non-existent addresses appearing on the display.

## Example 2: Mismatch between cables connecting indoor and outdoor units and corresponding piping. (all model)

### ■ Situation

The remote controller is not showing any malfunction and the system is operating but there is no flow of warm air from the indoor unit (in heating mode).

### ■ Source of problem and remedial action

The connecting cables and the corresponding piping were not correctly matched.

Recabling was carried out and the fault disappeared.

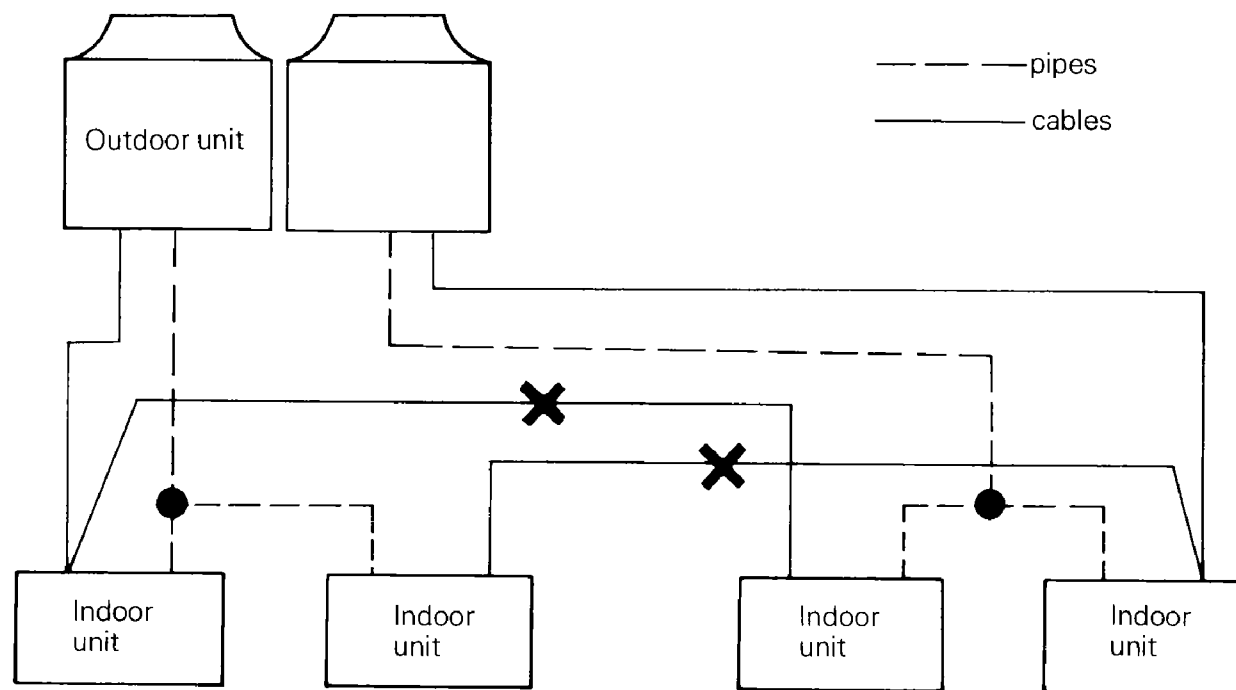

### ■ Main points

- Special care must be taken when the pipework and cabling are carried out by different people.
- Run each indoor unit in turn to check that the system is correctly matched.

### Example 3: Drain pipe trap shape defective

#### ■ Situation

Indoor unit was fitted with a drain trap but a leak occurred during subsequent operation.

#### ■ Source of problem and remedial action

The trap was not properly shaped thus preventing it from functioning effectively as a trap and resulting in drain leakage. The trap was reshaped and the fault disappeared.

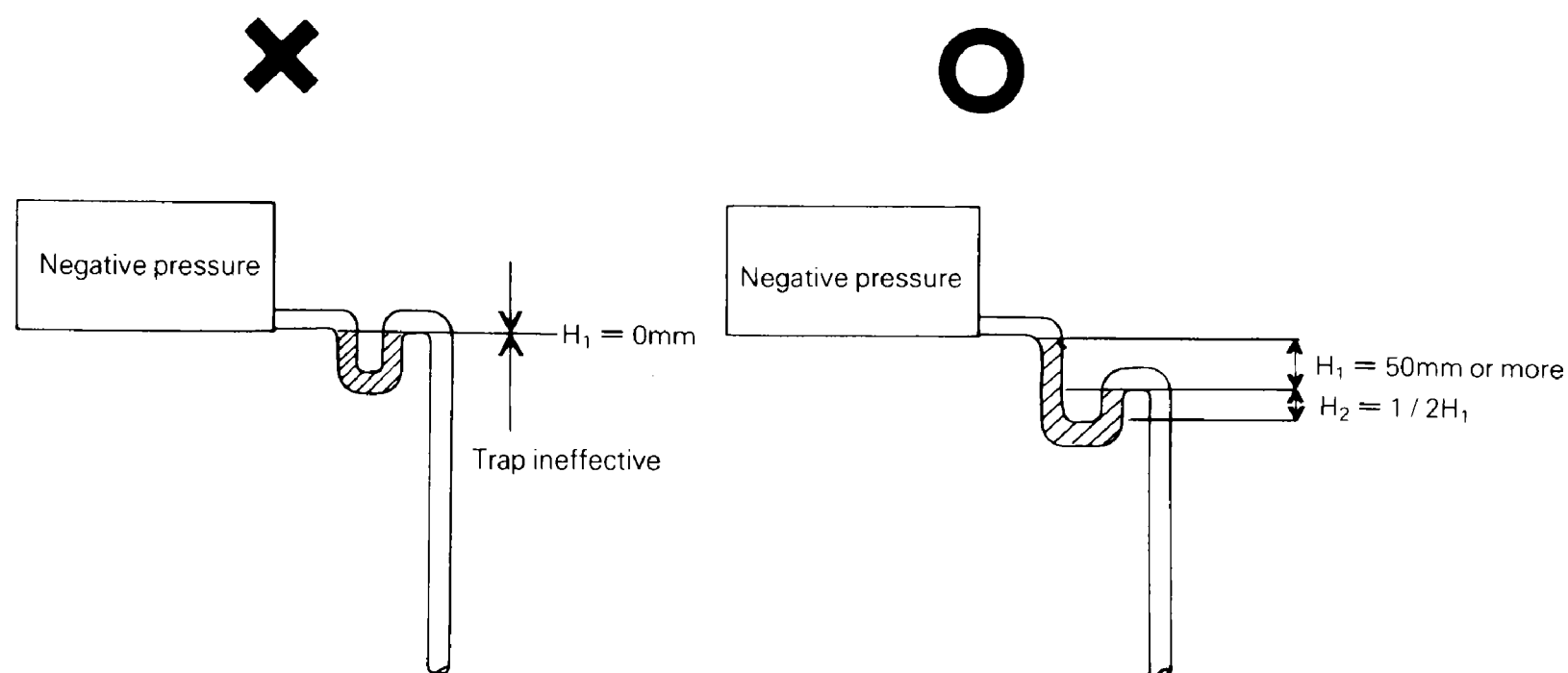

#### ■ Main points

- Built-in and duct types require a drain trap.

Reason: There is resistance on the air inlet side caused by the heat exchanger and air filter and this in turn creates negative pressure in relation to the atmospheric pressure on the discharge side. If there is no drain trap then air will be drawn in from the drain pipe and the waste water splashed around giving rise to the risk of water overflowing from the drain pan. To avoid this problem it is therefore necessary to design a trap which takes account of the maximum negative pressure which is likely to be created on the suction side.

## Example 4: Pressure down despite absence of leaks during air tight test (all model)

### ■ Situation

In order to carry out local air tight tests on the refrigerant piping the system was pressurized (28 kg/cm<sup>2</sup>) via the liquid pipe service port and after 24 hours the pressure was found to have fallen. The local refrigerant piping alone does not lose any pressure. Maybe the gas leak is supposed to be located in the indoor unit itself.

### ■ Source of problem and remedial action

The system was pressurized from the liquid pipe side and the gas pipes were therefore not pressurized. The system was then left under pressure for 24 hours but during that time gas leaked through into the gas pipes due to internal leaks within the solenoid and check valves and the gas pressure inside the liquid pipes consequently dropped.

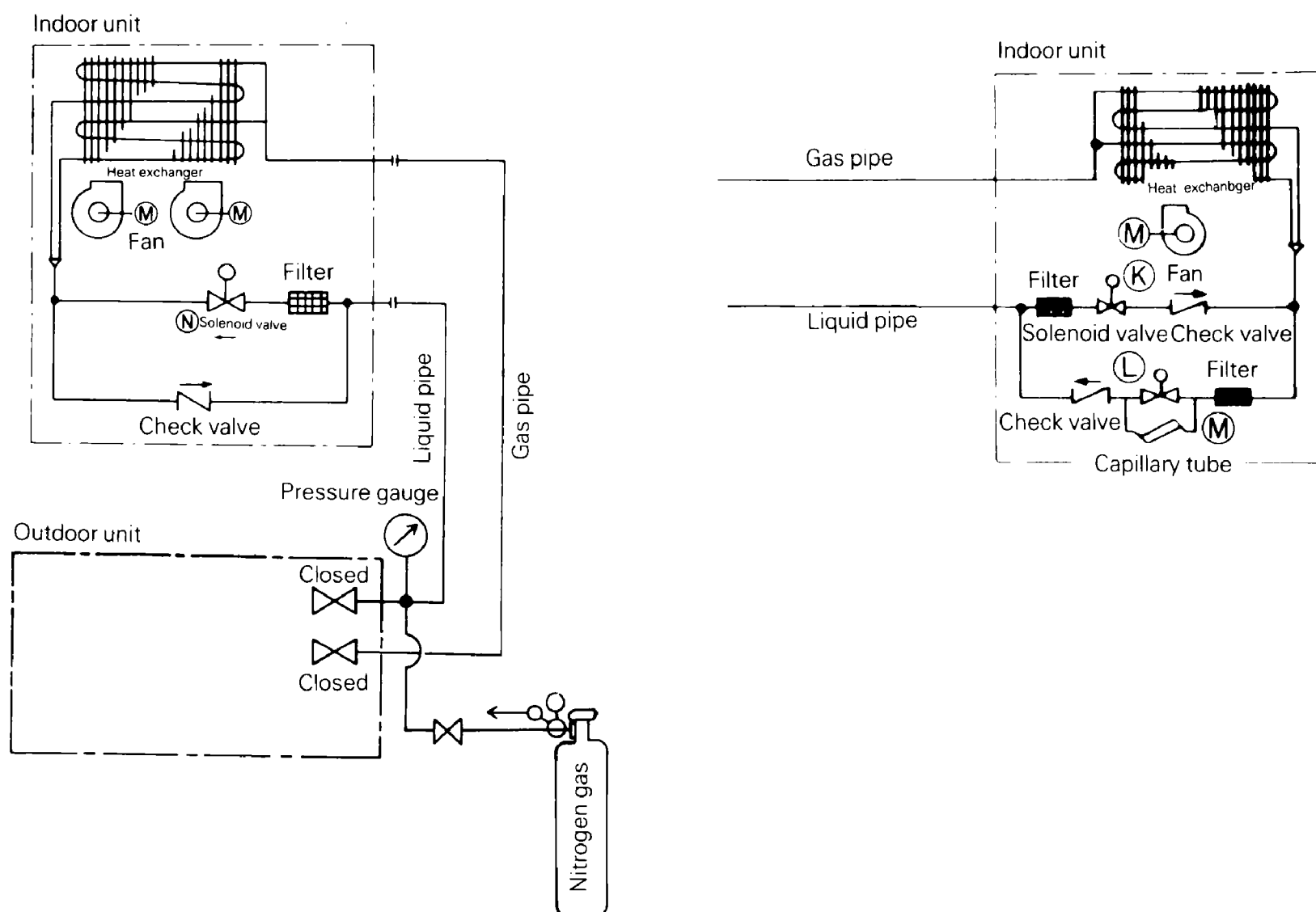

### ■ Main points

- When carrying out air tight tests on local pipework it is essential that the system be pressurized via both the liquid pipes and the gas pipes.

## Example 5: Excessive noise due to incorrect angling of REFNET joints

### ■ Situation

The noise of the refrigerant flow during defrosting is excessive.

### ■ Source of problem and remedial action

The angle of the fittings was incorrect and needed to be rectified as shown in the following figure.

#### ① REFNET joints

The REFNET joints should be installed such that branches meet the main pipe either horizontally or vertically at an angle of exactly 90 degrees.

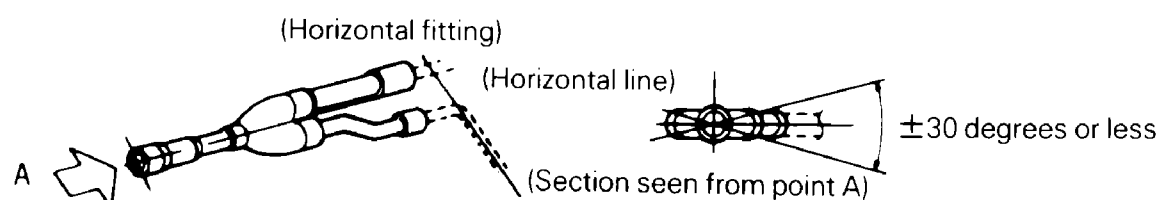

- When joining pipes with lateral flow the angle created by the 2 branch pipes must be  $\pm 30$  degrees or less.

(Vertical fitting)

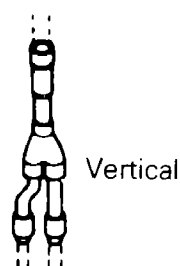

- When joining pipes with vertical flow the angle of the joint must be absolutely vertical.

#### ② REFNET header

The REFNET header is a lateral flow pipe and should be fitted so as to allow horizontal branch fittings. (Vertical or sloping fitting is not permissible.)

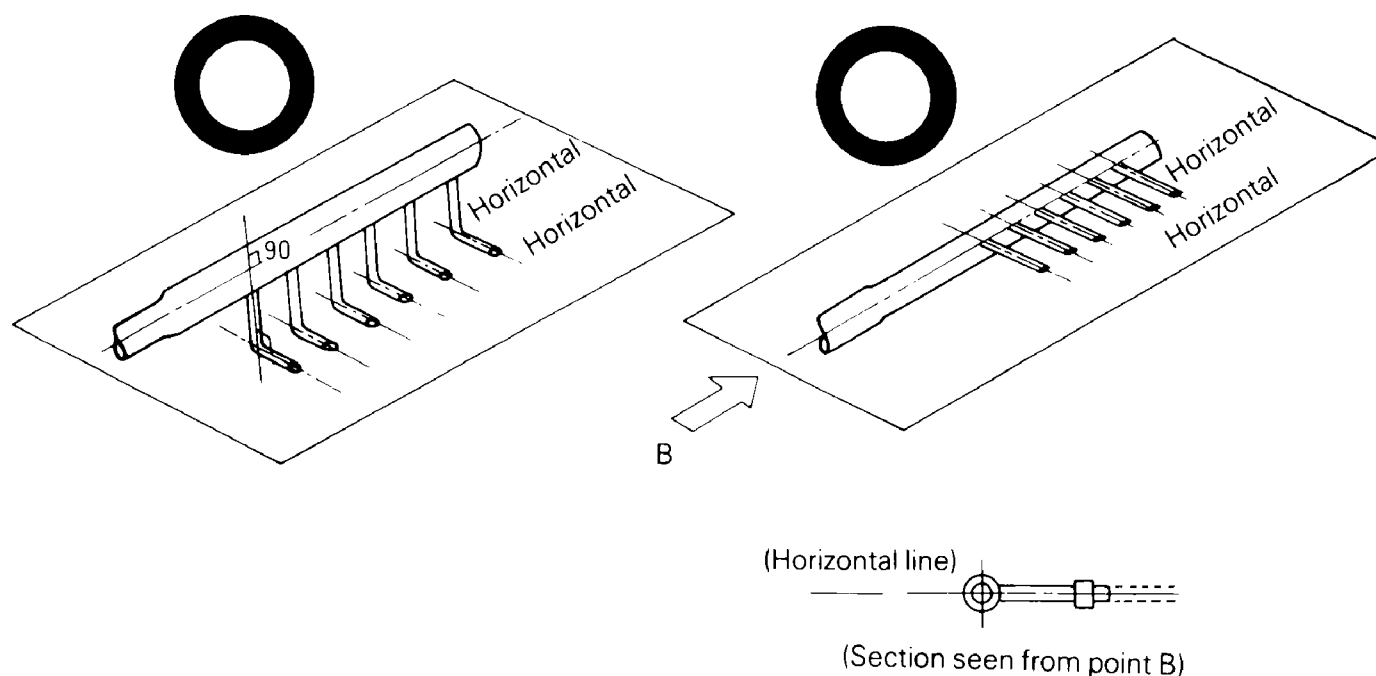

### ■ Main points

- Reasons for using refrigerant branch kit

Fittings of REFNET joints or headers which are not carried out in strict accordance with the principles outlined here may result in complaints relating, for example, to "poor performance" of the system or "noisy refrigerant flow". (To prevent unbalance flow or oil shortage)



## Example 6: Cracks develop in field pipes due to thermal expansion and contraction

### ■ Situation

Refrigerant piping has developed cracks in soldered points and is leaking gas.

### ■ Cause

Both ends of the pipe have been tightly fixed in place.



Starting and stopping the compressor has caused temperature to vary, thus the pipes have expanded and contracted which places stress on soldered parts.



Cracks have formed because of repeated expansion and contraction.

### ■ Remedial action

Fit the pipe with a loop as shown in the below drawing.

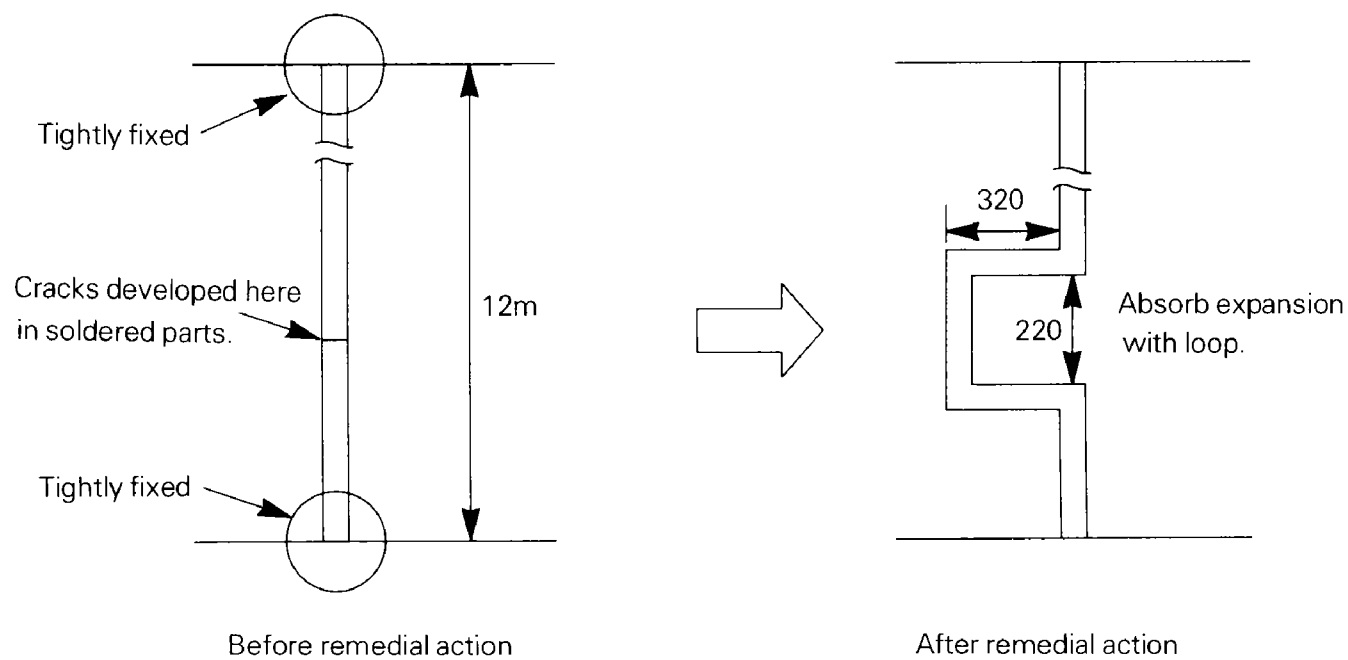

### ■ Main points

- Take thermal expansion and contraction along the spline into consideration when installing pipe supports.

### ■ For your reference

Expansion (m) = Full length × Coefficient of thermal expansion × Rise in temperature

Coefficient of thermal expansion for copper:  $16.5 \times 10^{-6}$

Example For a pipe length of 10 m and a rise in temperature of 50°C, expansion reaches 8.2 mm.

## Example 7: Transmission wiring between the cool/heat selector and the outdoor unit is too close to a high voltage wire.

### ■ Situation

Heating is indicated despite having selected cooling with the cool/heat selector.

### ■ Cause and remedial action

The transmission wiring between the cool/heat selector and the outdoor unit is too close to a high voltage wire. An induced voltage is, therefore, being impressed on the transmission wiring which is causing a heating/cooling malfunction in the outdoor unit PC board.

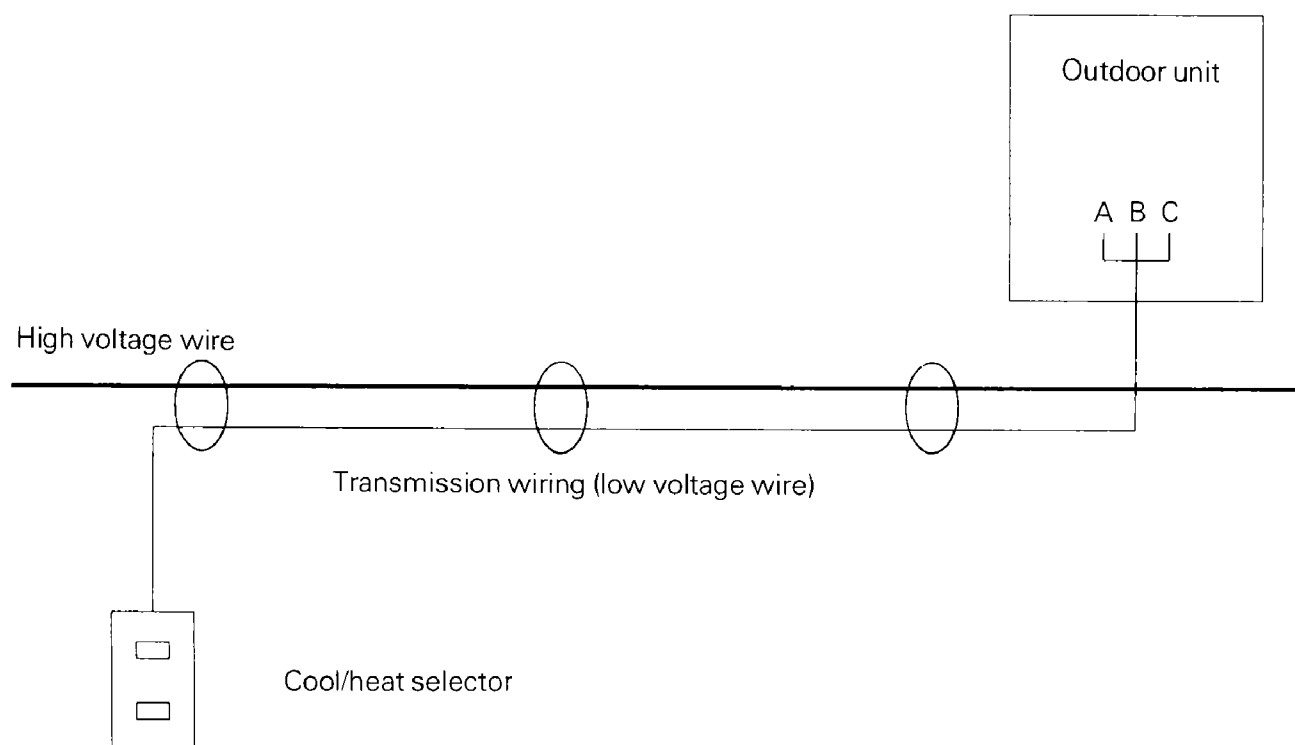

Bypassing the transmission wiring will allow the unit to function normally.

### ■ Main points

- Keep low and high voltage wiring away from each another.

## Example 8: The centralized control group number cannot be set (Inverter K Series).

### ■ Situation

An attempt was made to set the centralized control group number with the indoor unit remote controller, but “00” cannot be selected in the field setting mode.

### ■ Cause

- (1) The central remote controller or unified ON/OFF controller is OFF.
- (2) The central remote controller or unified ON/OFF controller, or indoor unit is not wired to the centralized control line (F1 & F2).

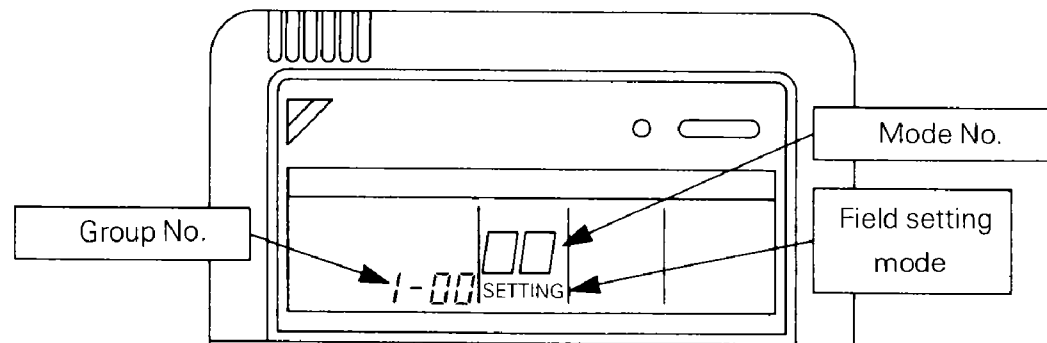

### ■ Remedial action

- Supply power to either the central remote controller or unified ON/OFF controller.
- Wire the central remote controller or unified ON/OFF controller, or indoor unit to the centralized control line.

### ■ Main points

- When communications with the central remote controller are down, “00” cannot be selected in the field setting mode.
- Activate power to the central remote controller, unified ON/OFF controller and indoor unit before setting the centralized control group number.

## Example 9: "88" cannot be cleared from the central remote controller.

### ■ Situation

The display on the central remote controller does not change from its initial state after turning power ON.

Initial display of the central remote controller

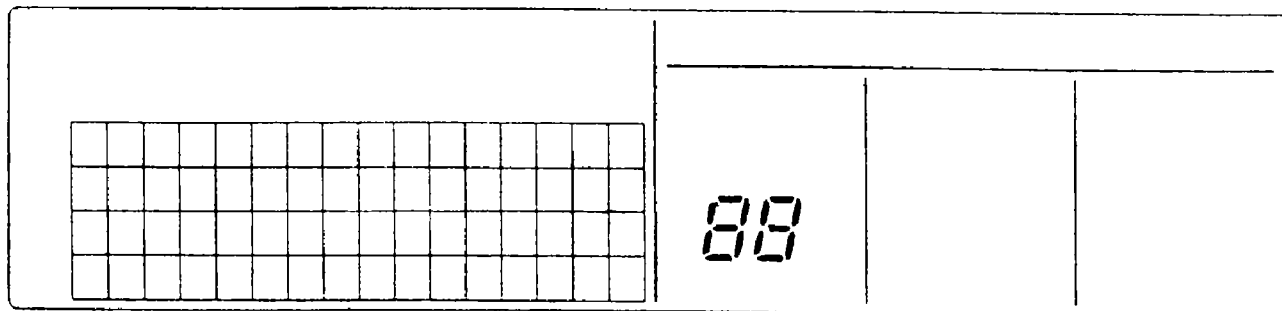

### ■ Cause

- (1) None of the indoor units connected to the central remote controller have been given a group No.
- (2) The connector for setting the master controller inside the central remote controller is disconnected.

### ■ Remedial action

- Set a centralized control group No. for each indoor unit with the respective remote controllers.
- Connect the connector for setting the master controller in one of the central remote controller.

### ■ Main points

- If the setting for master controller has been changed, reset the power to the unit at the ON/OFF switch or the forced reset switch of the controller.
- Activate power to the central remote controller, unified ON/OFF controller and indoor unit before setting the centralized control group No.
- For details on how to set the centralized control group number, refer to the installation manual.

# Appendix

## Check points in installing VRV systems

1. Operating noise of indoor units
2. Procedures for rigging refrigerant piping
3. Piping system diagrams and refrigerant piping work for the Inverter K Series
4. Locating outdoor units
5. Precaution in control wiring work
6. Check this before performing a test run

# 1. Operating noise of indoor units

## (1) Difference between catalogue data and actual noise

Operating noise differs depending on the place of measurement (room) because of the various degrees with which the room reverberates the sound. To determine the amount of reverberation under uniform conditions, the unit has been measured in a dead room with results having been compiled in the below table. The actual sound produced in unit operation can be determined from Table 1.

Sound pressure rise due to room reverberation (Higher than catalogue data)

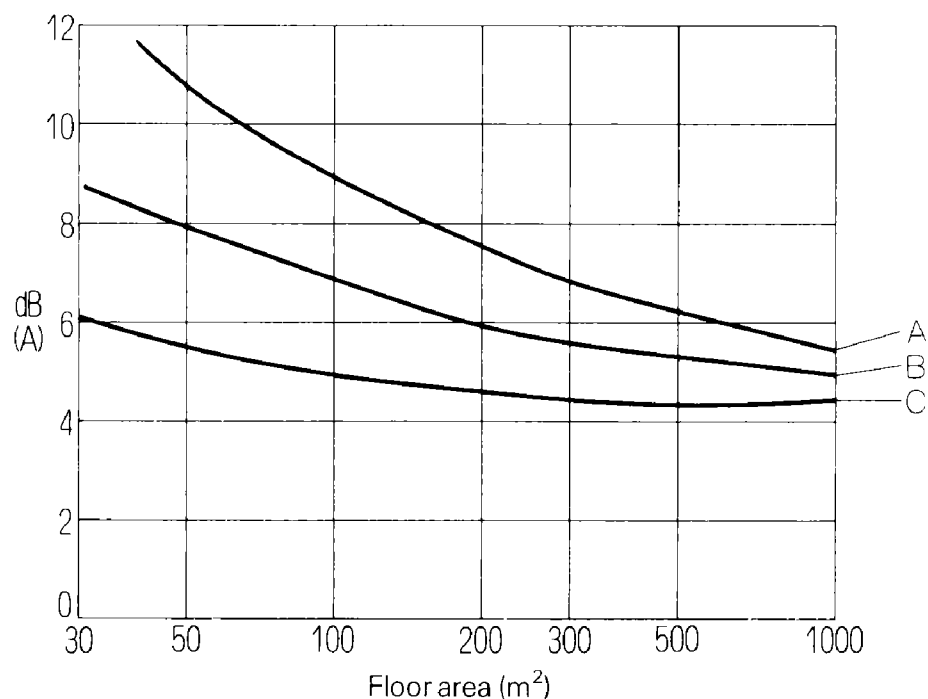

A, B, C: Types of rooms

Table 1

		A	B	C
Room interior detection	Floor	Mortar	Linoleum tile	Carpet
	Walls	Mortar	Plaster	Fiberglass + Saroncross finish
	Ceilin	Mortar	mineral wool tile	Fiberglass + Saroncross finish
Average absorbed sound (room with approx. 50 m <sup>2</sup> floor area)		0.05	0.12	0.25
		Typical office		
Estimated value to be added to catalogue value		11~12	8~8.5	5~6

## Classifications of indoor unit environments (reference data)

Table 2

Classification	Environment	Example	Faint noises (NOTE 2)	Recommended operating noise on site
I	Non-active places requiring silence	Reception rooms, libraries, sitting rooms, hospitals (examining rooms) (NOTE 1)	~35	~40
II	Sedate business activities that do not disturb people even over time	Quiet offices, classrooms, small conference rooms, lobbies	~40	~45
III	Somewhat quiet settings that permit soft-spoken conversation, typical activities	Small offices, large conferences rooms, quiet stores, restaurants	~45	~50
IV	Somewhat loud settings that permit regular conversation, brisk activity	Large offices, typical stores, cafeterias	~50	~55
V	Loud places that permit conversation in a loud voice, highly active place with many people	Loud large-side offices, large cafeterias, loud stores	~55	~60
VI	Rather loud settings	Factories, gymnasiums, recreational places like pachinko parlors	~60	~65

NOTE 1: Excluding bedrooms

NOTE 2: Reference values of faint noises in the place of usage

## (2) Faint noises and correcting operating noise with respect to faint noises

Faint noises are defined as peripheral sounds existing while the unit is not running, which are picked up when measuring operating noise. If these faint noises are 10 dB or more than the noise produced by the unit, the measured value can be taken as the operating noise of the unit. But, the difference must be corrected if less than 10 dB, because of the effect these noises have on the actual measured value. Also, when the sound meter remains unchanged even while the unit is stopped, we can determine the operational noise to be at least 10 dB less than the faint noises, but we cannot pinpoint the operating noise exactly.

For example, if the faint noises are some 65 dB and the noise produced by the unit in operation is 70 dB, the indicated difference comes to 5 dB. Using Table 3, we recommend you correct the operating noise by about 2 dB to 68 dB.

Table 3 Correcting the effect of faint noises

Unit: dB

Difference between when noise is produced and when not	1	2	3	4	5	6	7	8	9	10
Corrective value	-6.9	-4.4	-3.0	-2.3	-1.7	-1.25	-0.95	-0.75	-0.60	-0.45

## (3) Calculating operating noise

When two or more units are running at the same time, the amount of operating noise they produce rises. The total amount of noise produced can be obtained ahead of time with Chart 4.

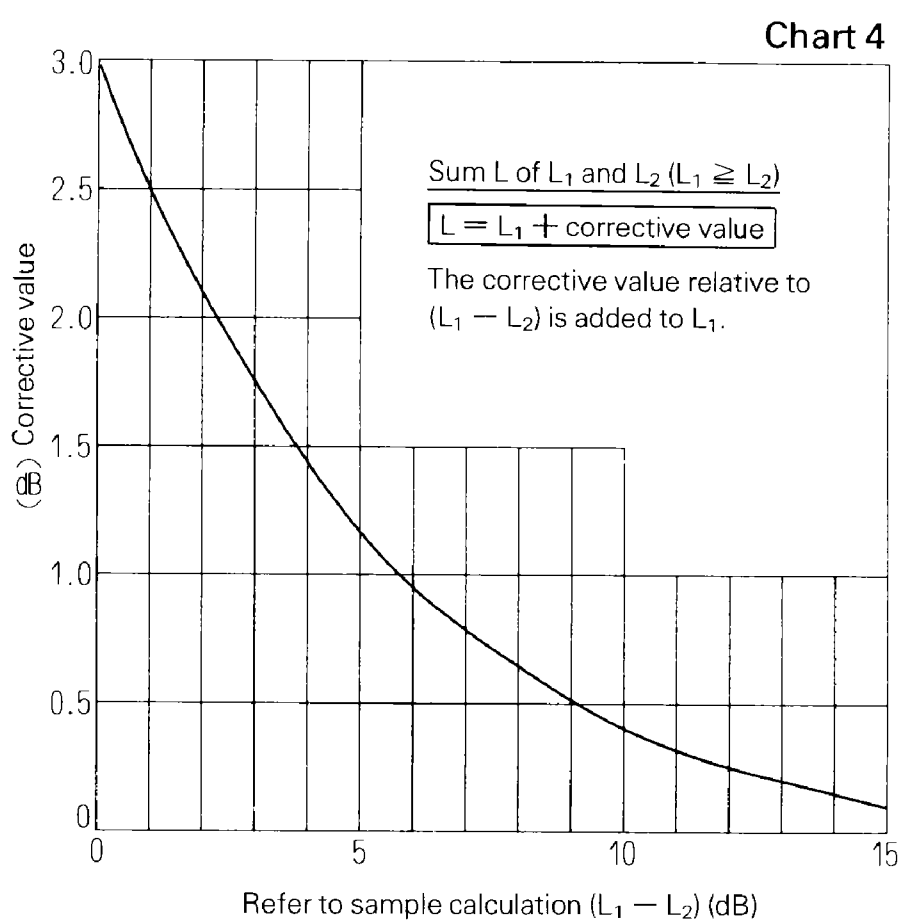

### Sample calculation 1

$L_1$  and  $L_2$  are given as compounded sounds of 50 and 49 dB respectively. Since  $L_1 - L_2 = 50 - 49 = 1$ , the corrective value is 2.5, therefore  $50 + 2.5 = 52.5$  dB.

### Sample calculation 2

When sounds of 40 dB, 38 dB, 37 dB and 40 dB are placed in order of magnitude, we obtain the following:

40 dB, 40 dB, 38 dB, 37 dB

To start, the difference between 40 dB and 40 dB is 0, therefore we take a corrective value of 3dB and obtain  $40 + 3 = 43$  dB. The compounded sound of 43 dB and 38 dB has a 5.0 dB difference, thus a corrective value of 1.2 dB, which gives us 44.2 dB from  $43 + 1.2$ . In the same manner, the corrective value for 44.2 dB and 37 dB is approximately 0.7 dB, or in other words,  $44.2 + 0.7 = 44.9$  dB.

## 2. Procedures for rigging refrigerant piping

### (1) REFNET pipe components (option)

RSX(Y)5K KHRJ26K11T (less than 100)	
<p>● Suction gas side</p>	<p>● Liquid side</p>
● Including insulator, cap pipes and tapes	
KHRJ26K17T (100 or more)	
<p>● Suction gas side</p>	<p>● Liquid side</p>
● Including insulator, cap pipes and tapes	
RSX(Y)8K·10K KHRJ26K18T (less than 160)	
<p>● Suction gas side</p>	<p>● Liquid side</p>
● Including insulator, cap pipes and tapes	
KHRJ26K37T (160 or more)	
<p>● Suction gas side</p>	<p>● Liquid side</p>
● Including insulator, cap pipes and tapes	



RSX(Y)5K

KHRJ26K11H (4 branch fitting) (less than 100)

● Suction gas side

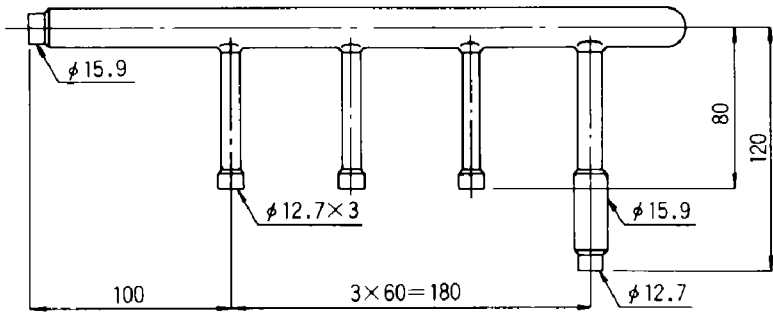

● Liquid side

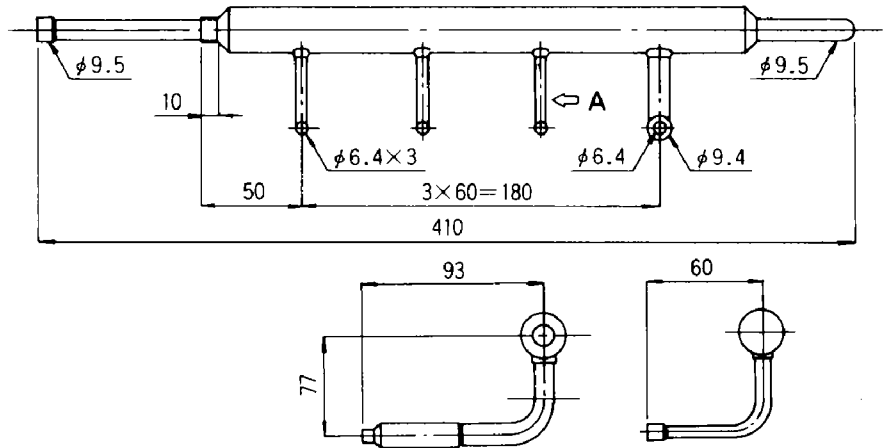

● Including insulator, cap pipes and tapes

KHRJ26K17H (8 branch fitting) (100 or more)

● Suction gas side

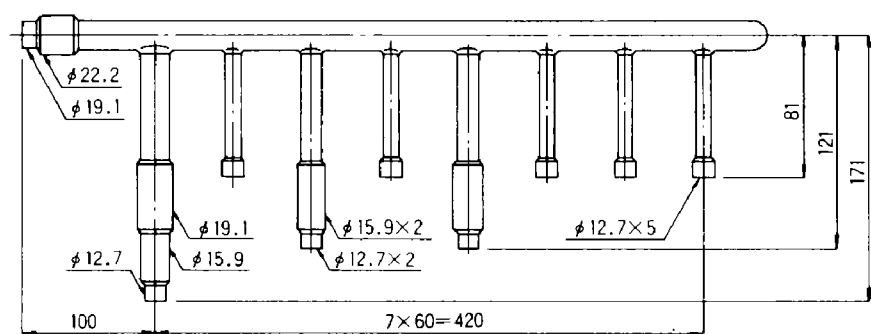

● Liquid side

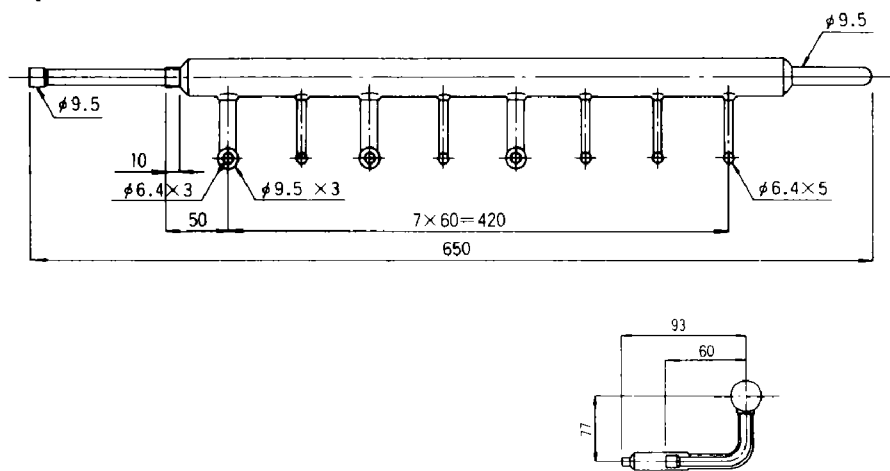

● Including insulator, cap pipes and tapes

RSX(Y)8K, RSX(Y)10K

KHRJ26K18H (6 branch fitting) (less than 160)

● Suction gas side

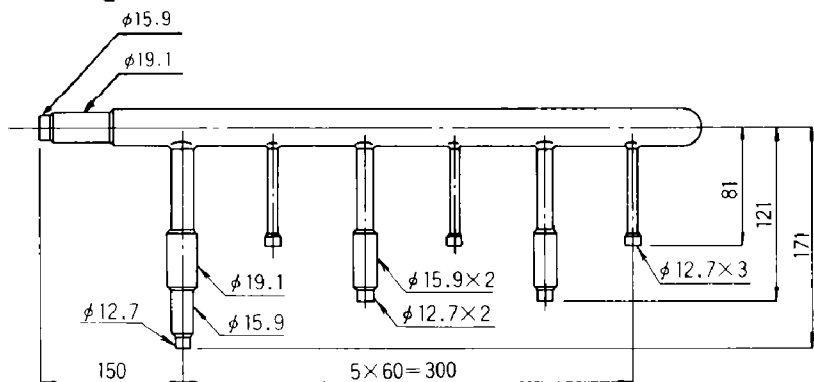

● Liquid side

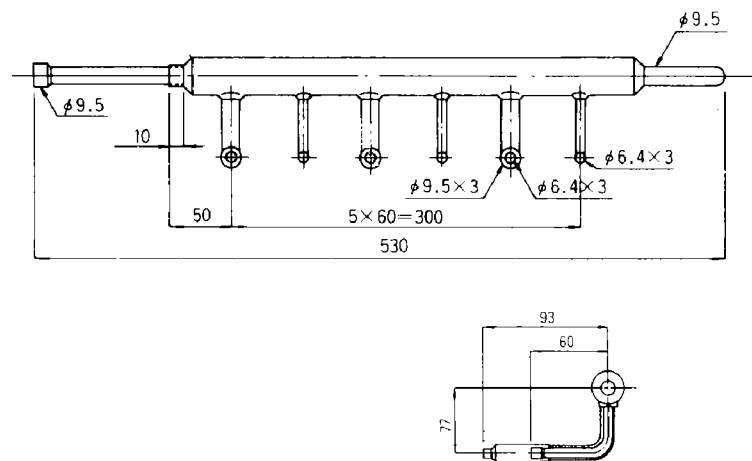

● Including insulator, cap pipes and tapes

KHRJ26K37H (8 branch fitting) (160 or more)

● Suction gas side

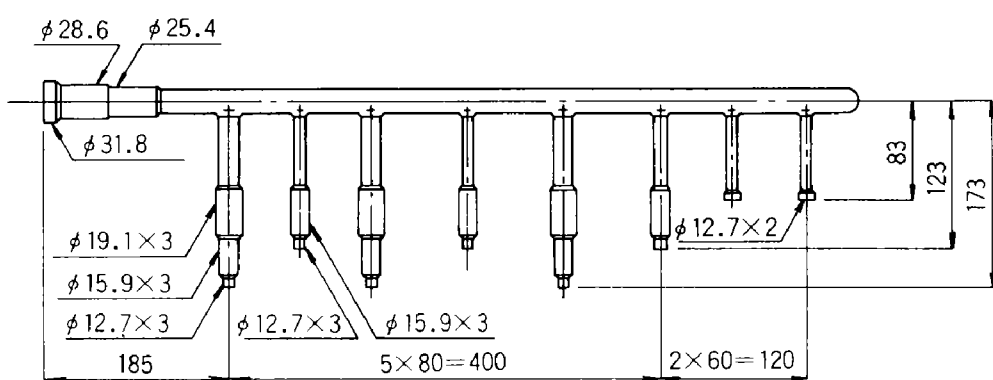

● Liquid side

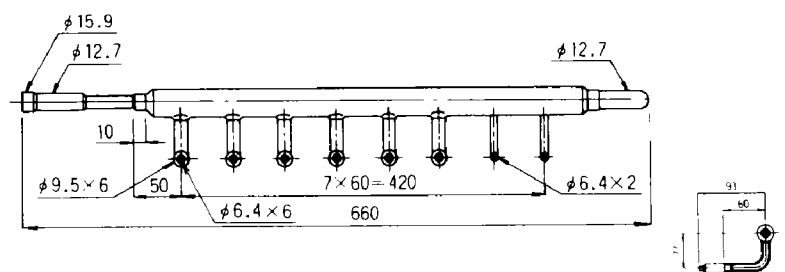

● Including insulator, cap pipes and tapes

## (2) Types of refrigerant piping

Outdoor unit	Total capacity of indoor units	Gas pipe size	Liquid pipe size
RSXY5H(J)	Less than 100	φ 15.9	φ 9.5
RSXY8H(J) RSXY10H(J)	Less than 100	φ 15.9	φ 9.5
	100 or more Less than 160	φ 19.1	φ 9.5
	160 or more	φ 25.4	φ 12.7

} Addition required for small capacity connection

- ① Match piping size to the connecting pipe of the outdoor unit when rigging a line between the outdoor unit and REFNET joint.
- ② Match piping size to the connecting pipe of the indoor unit when rigging a line between the REFNET joint and indoor unit.
- ③ REFNET header and joint size vary with model. For details, refer to system reference materials.

## REFNET joint and header installation

### ① REFNET joint

(Gas line and liquid line branch pipe)

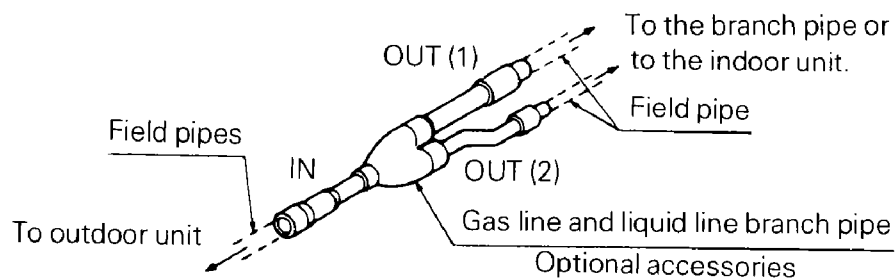

- If the selected building pipe differs from the branch pipe in size, cut the connection with a pipe cutter as shown below.

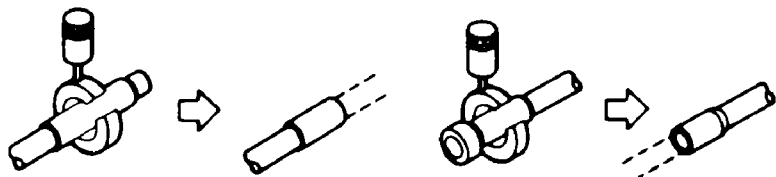

- Install the branch pipe either vertically or horizontally.

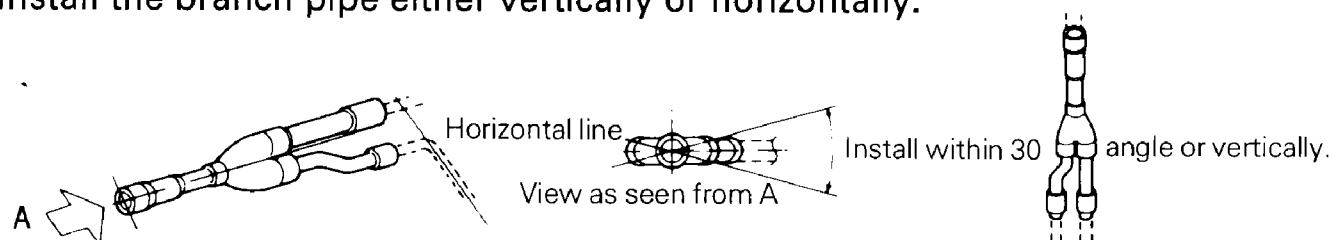

- Insulate the branch pipe as described in the kit installation manual.

### ② REFNET header

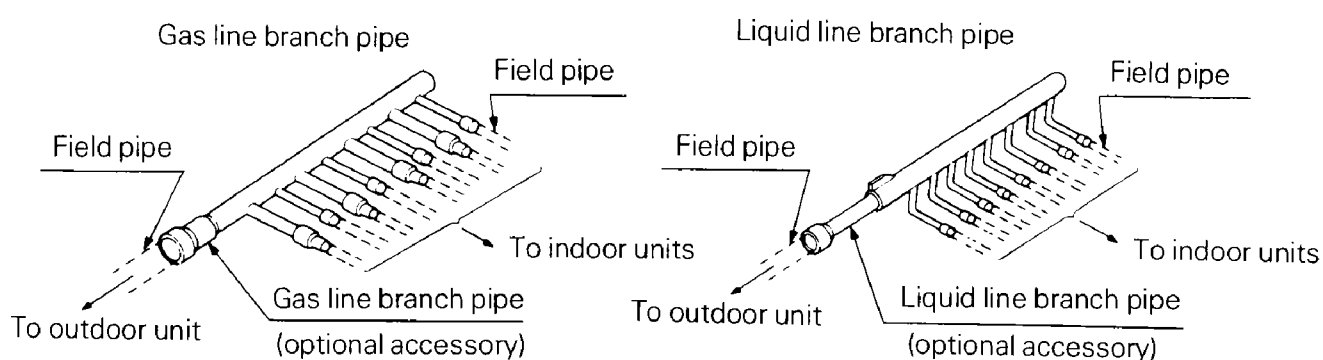

- If the selected field pipe differs from the branch pipe in size, cut the connection with a pipe cutter as shown below.

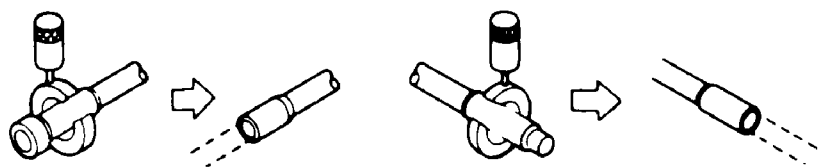

- Fit a stop end on all open branch pipe connections not in use.

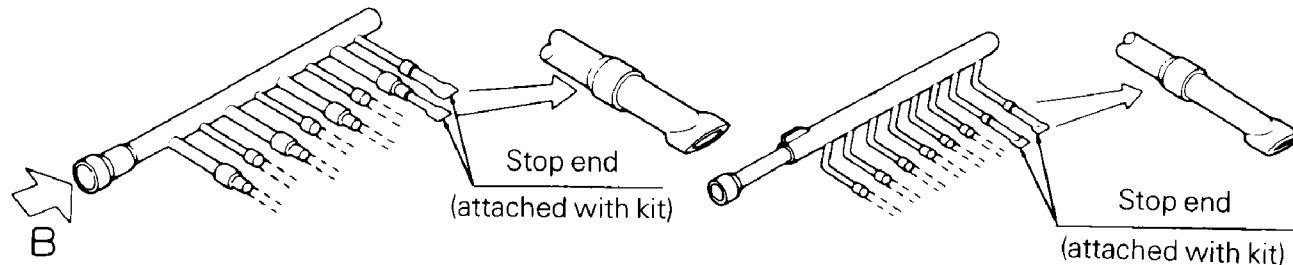

- Install the branch pipe horizontally.

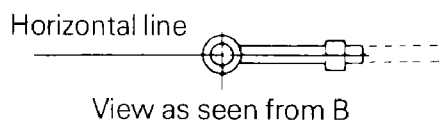

- Insulate the branch pipe as described in the kit installation manual.

### NOTE

- Install the REFNET joint horizontally or vertically, keeping it within a 30° angle when installed horizontally.
- Install the REFNET header so that it branches horizontally.
- Do not use a T-joint for the branch pipe.

### 3. Piping system diagrams and refrigerant piping work for the Inverter K Series

#### ■ Indoor unit

- FXYC, FXYF, FXYK, FXYS, FXYM, FXYH, FXYA, FXYL, FXYLM

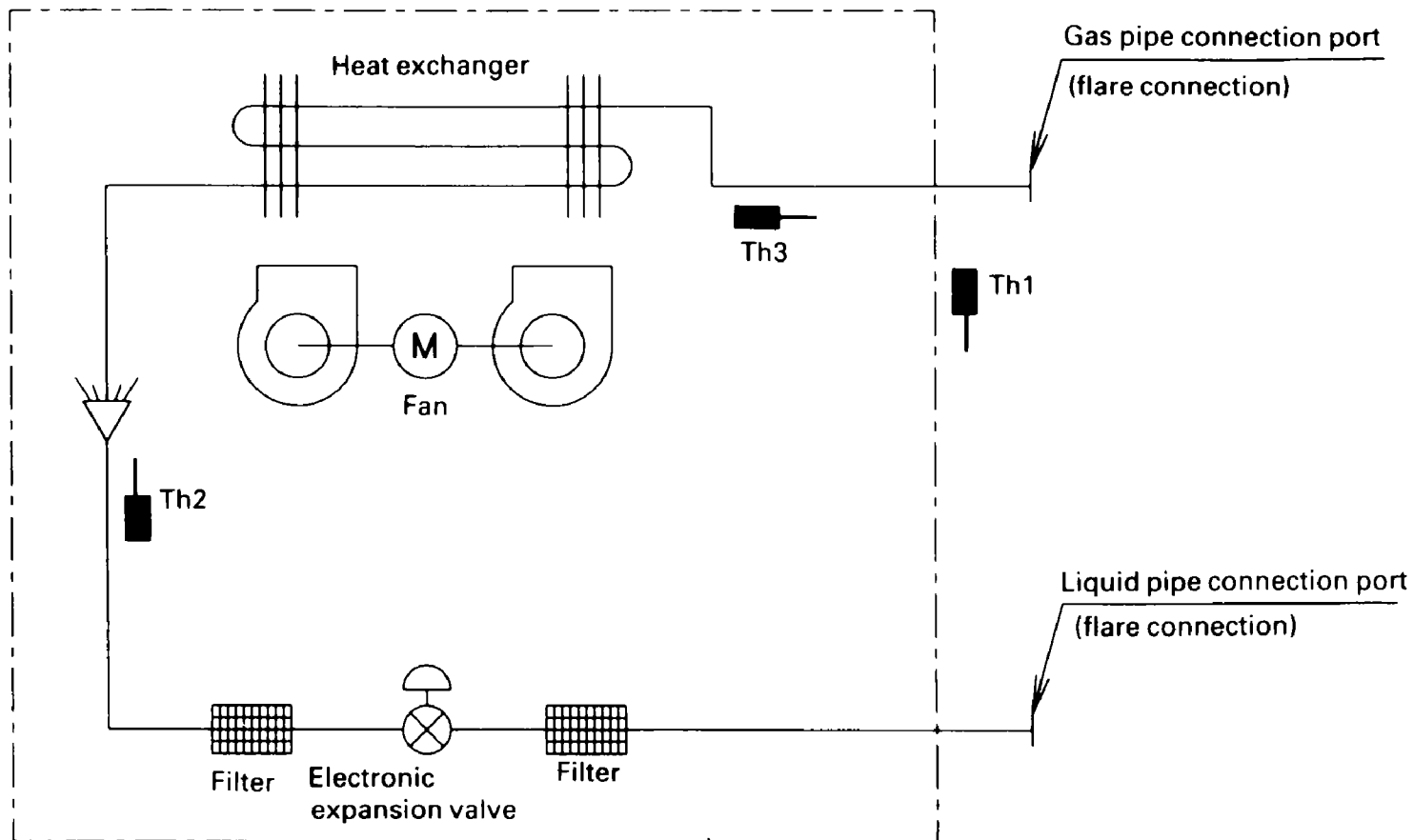

Th1: Thermister for suction air temp.  
 Th2: Thermister for liquid line temp.  
 Th3: Thermister for gas line temp.

#### ■ Refrigerant pipe connection port diameters

(mm)

Model	Gas	Liquid
FXYC20K/25K/32K/40K FXYF32K/40K FXYK25K/32K/40K FXYS20K/25K/32K/40K FXYM40K/50K FXYH32K FXYA25K/32K/40K FXYL25K/40K FXYLM25K/40K	φ12.7	φ6.4
FXYC50K/63K/80K FXYF50K/63K/80K FXYK63K FXYS50K/63K/80K FXYM63K/80K/100K FXYH63K FXYA50K/63K FXYL63K FXYLM63K	φ15.9	φ9.5
FXYC125K FXYF100K/125K FXYS100K/125K FXYM125K FXYH100K	φ19.1	
FXYM200K	φ25.4	
FXYM250K	φ28.6	φ12.7

Outdoor unit

RSXY5K

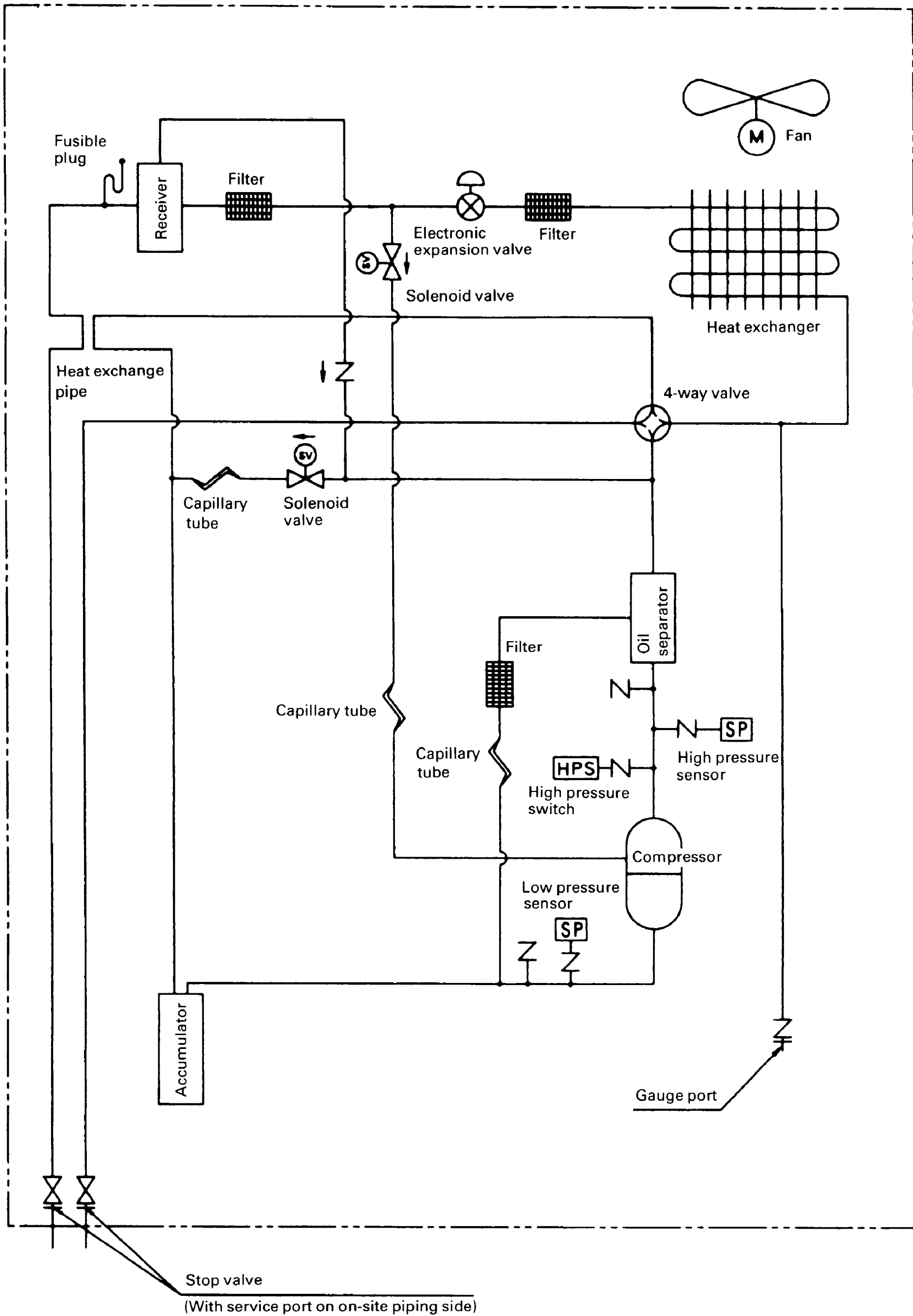

• RSXY8K-10K

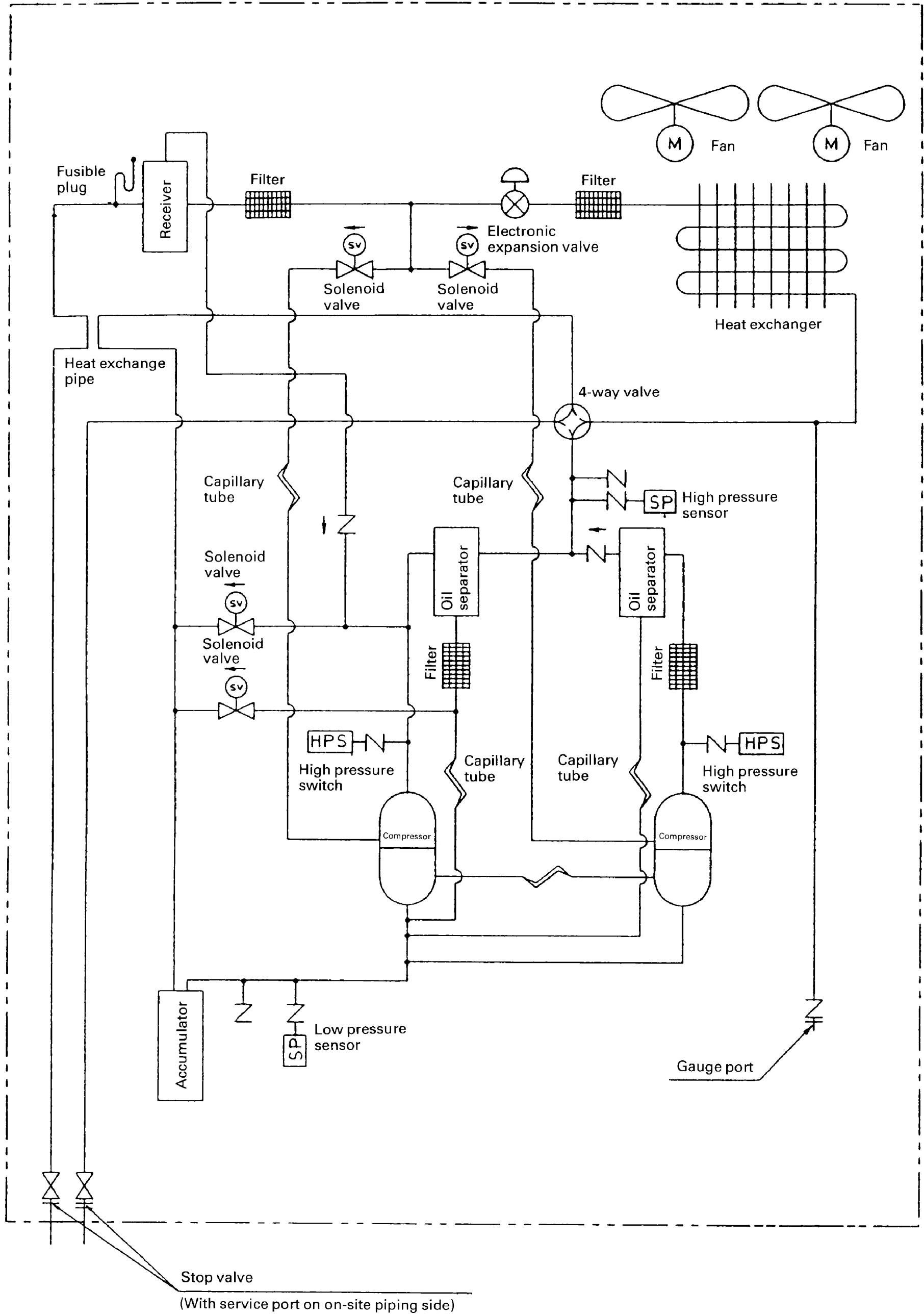

• RSX5K

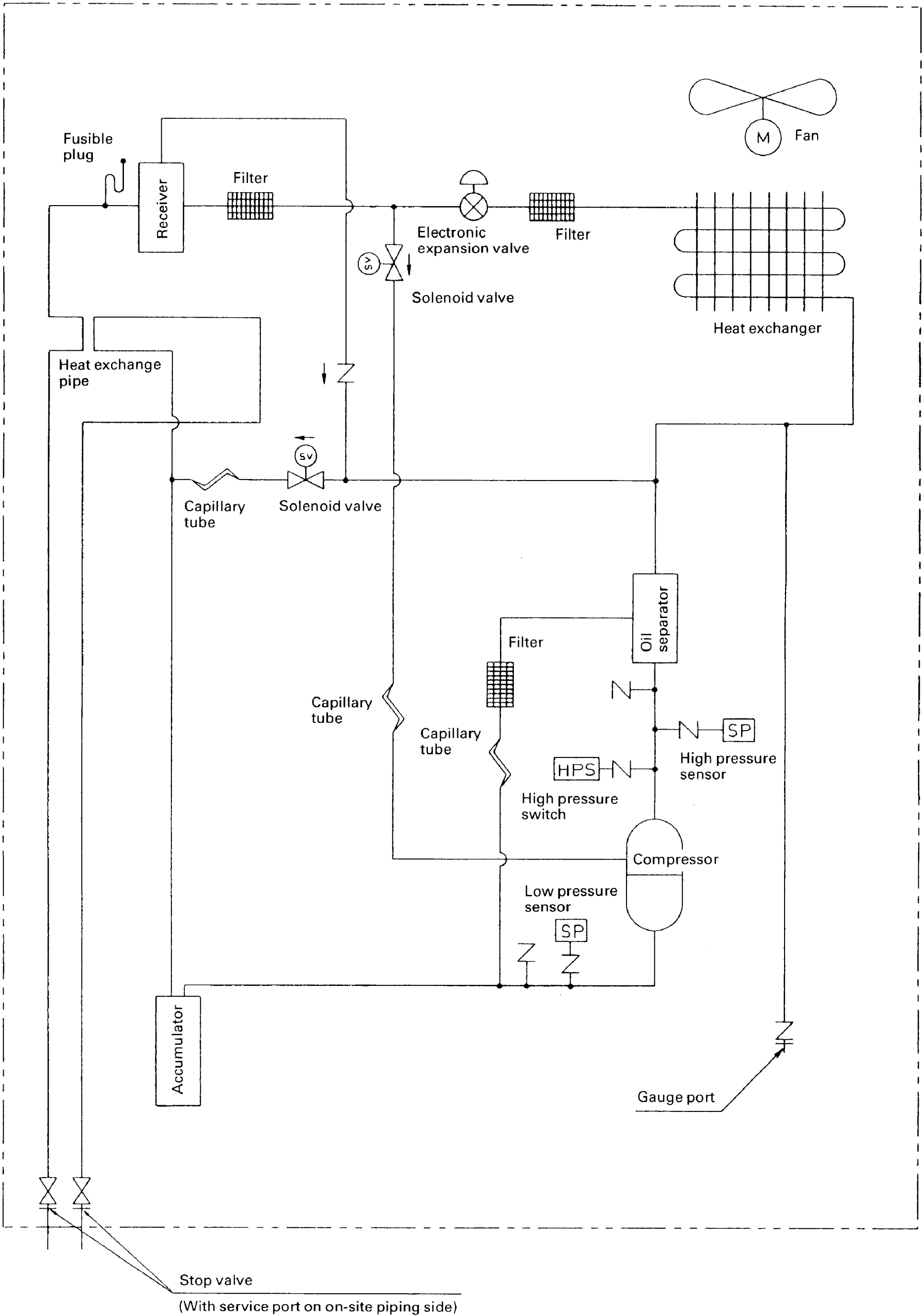

● RSX8K-10K

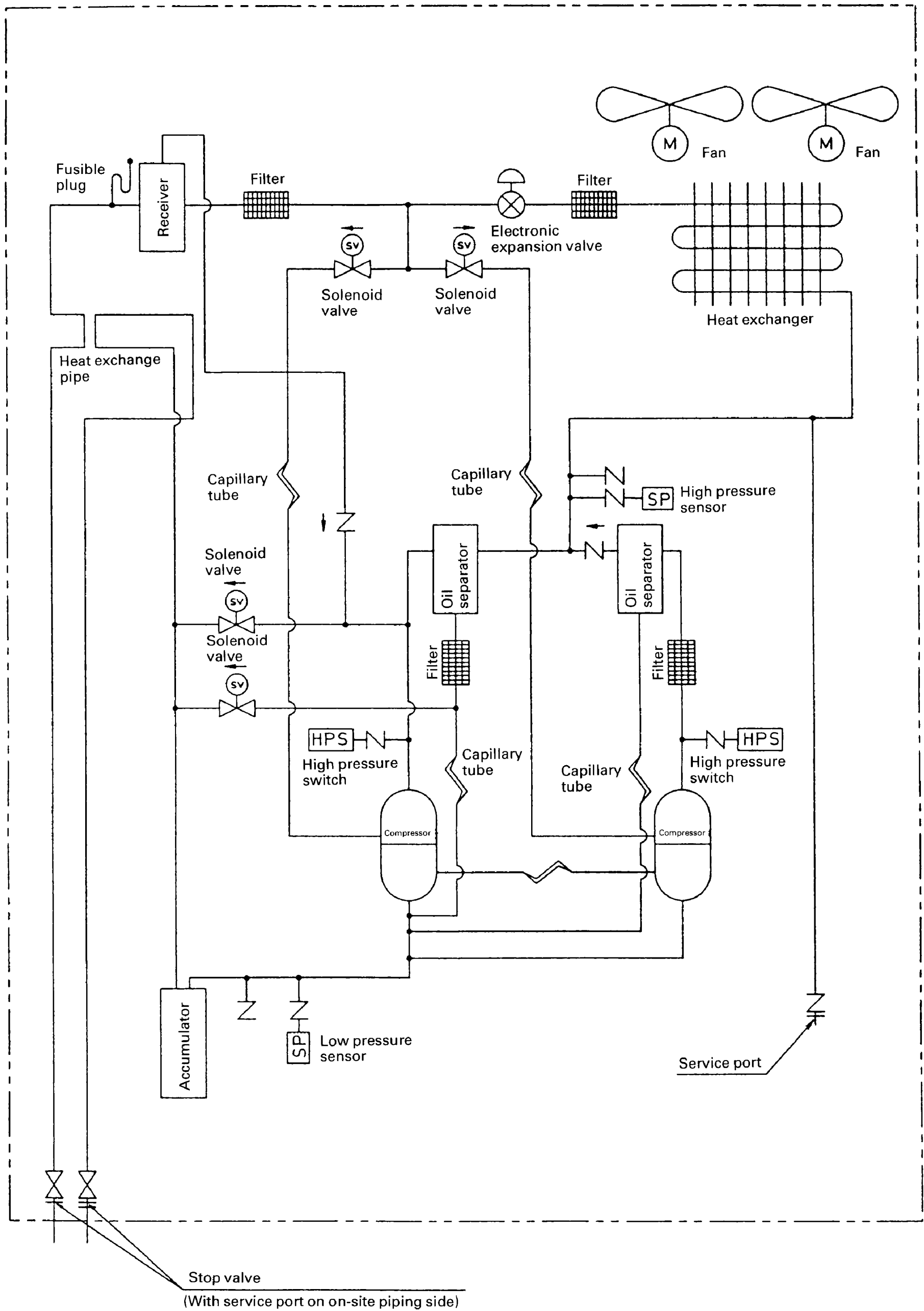



## 4. Locating outdoor units

Be careful to allow sufficient intake space and maintenance space.

### (1) Single unit installation

(Pattern No. 1)

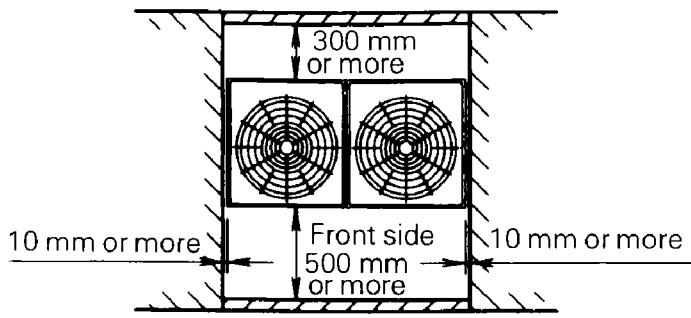

(Pattern No. 3)

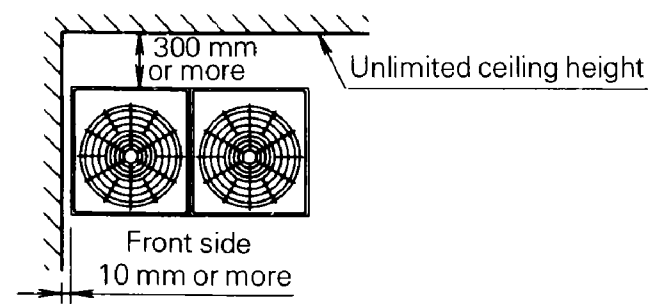

(Pattern No. 2)

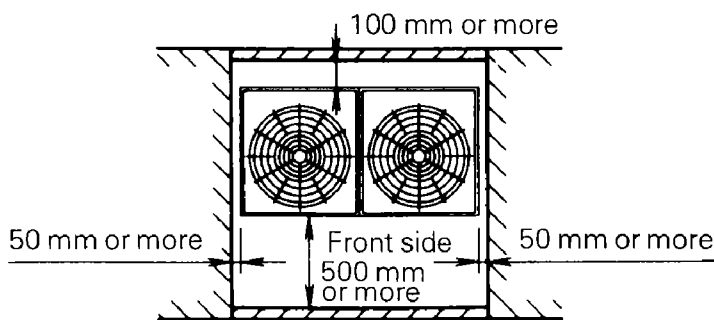

### (2) Multiple units in series

(Pattern No. 1)

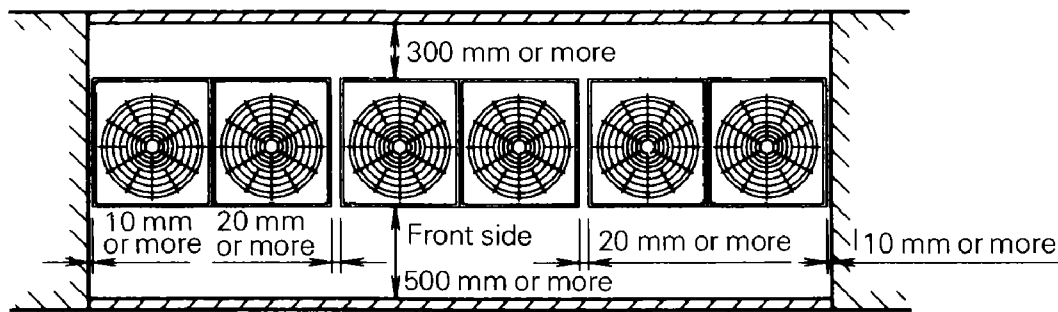

(Pattern No. 2)

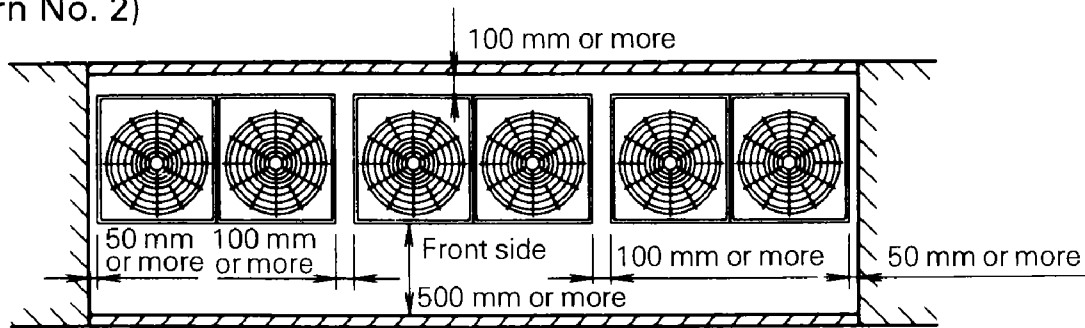

NOTE 1. Wall height for pattern No. 1 and pattern No. 2 is as follows.

Front side ... 1500 mm

Intake side ... 500 mm

Lateral ... Unlimited

NOTE 2. If exceeding the above wall height, add  $h_1/2$  and  $h_2/2$  to the front and intake side maintenance space as shown in the drawing on the right.

NOTE 3. Determine site space in accordance with corridors and air draft and select a pattern from those shown here.

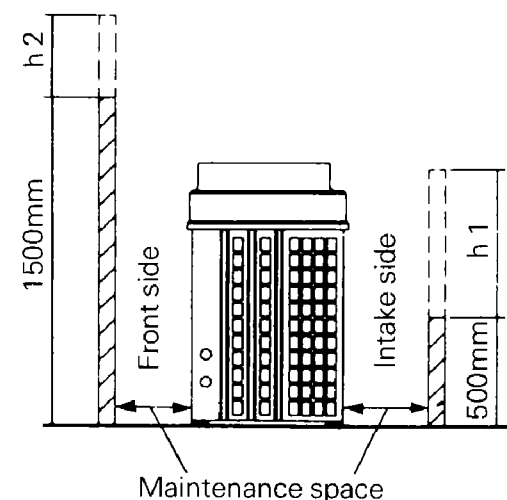

# 5. Precaution in control wiring work

## Electric wiring

### GENERAL INSTRUCTIONS

- All wiring, components and materials to be procured on the site must comply with the applicable local and national codes.
- Use copper conductors only.
- All field wiring and components must be provided by licensed electrician.
- Unit shall be grounded in compliance with the applicable local and national codes.
- Fit the power supply wiring with a fuse and a switch.
- After wiring work, check power to the equipment shuts OFF when switch is shut OFF.

### WIRING OUTLINE

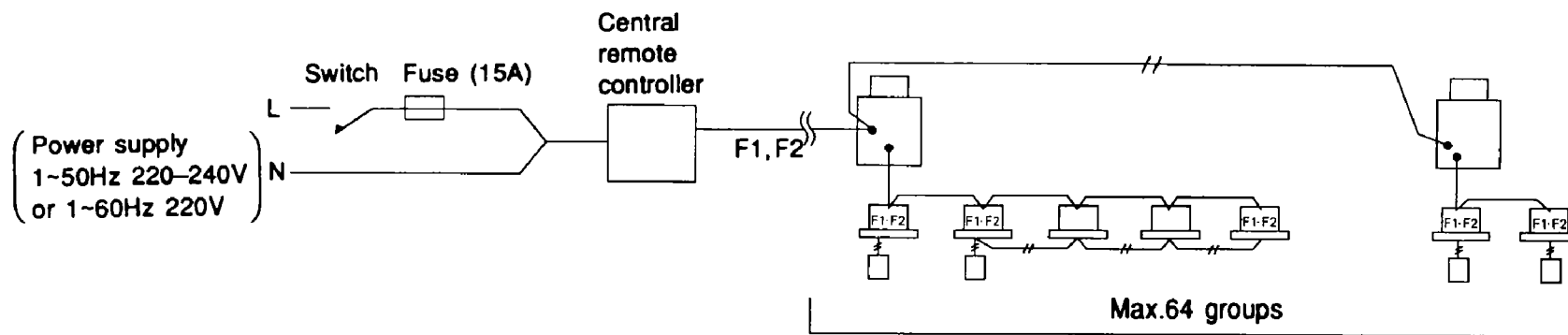

### Wiring specification

	Type	Size
Power supply wiring	H05VV-U3G	(NOTE 1)
Transmission wiring	(NOTE 2)	0.75 - 1.25 mm <sup>2</sup>

- NOTE) 1. The size of power supply wiring must comply with the applicable national and local codes.  
 2. Allowable length of transmission wiring is as follows.  
 • Max. 1000m (Total wiring length 2000m)

Connect the wiring between indoor and outdoor units, indoor/outdoor units and power supply, and indoor units and remote controllers.

For details, refer to the installation manuals of indoor and outdoor units.

### EXAMPLES OF WIRING FOR TRANSMISSION

#### ① Series wiring

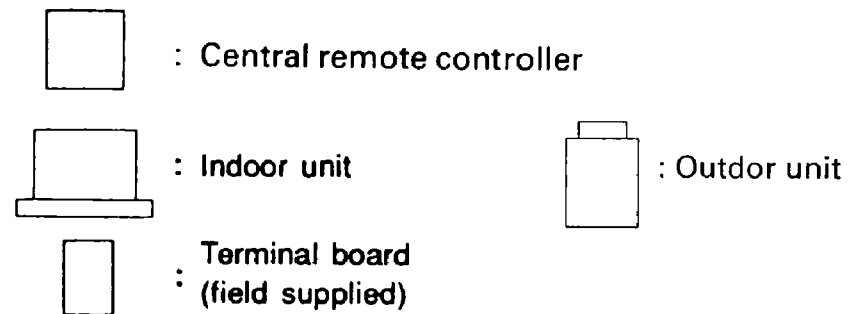
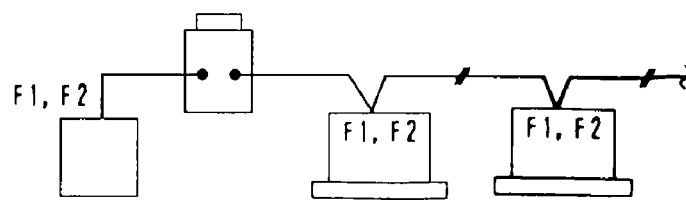

#### ② Bus type wiring (Can be branched up to 16 branchings) Example of 3 branchings

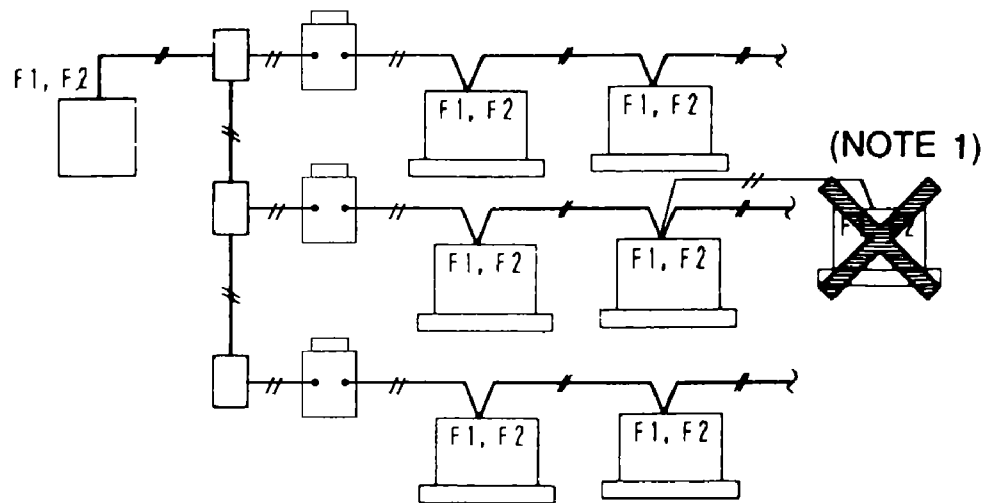

#### ③ Star type wiring (Can be branched up to 16 branchings) Example of 3 branchings

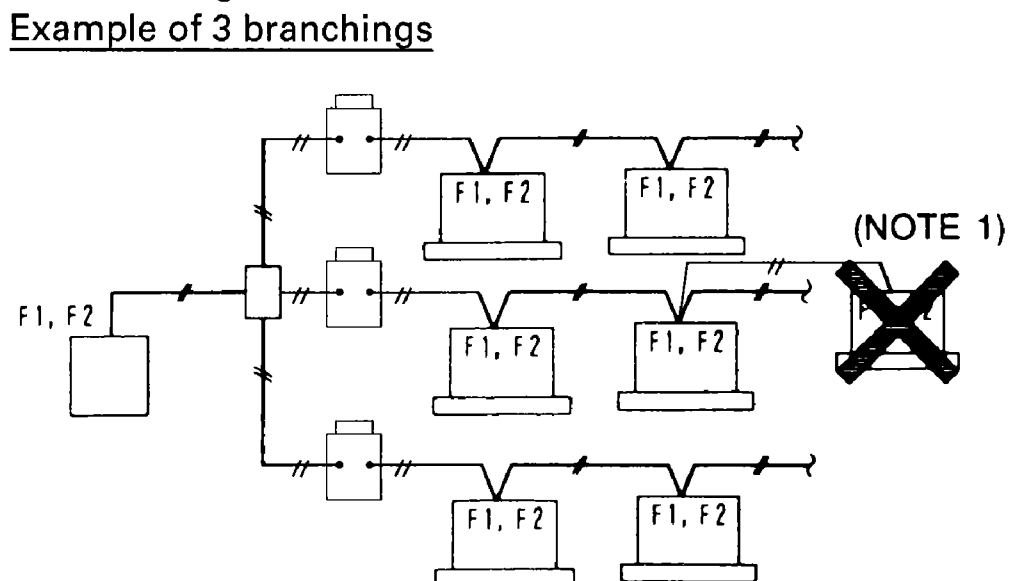

- NOTE) 1. No branching is allowed after branching.  
 2. Use a relay terminal board (field supplied) to branch more than 3 control wirings from the same terminal board.

## WIRING TO THE INDOOR UNIT AND OUTDOOR UNIT

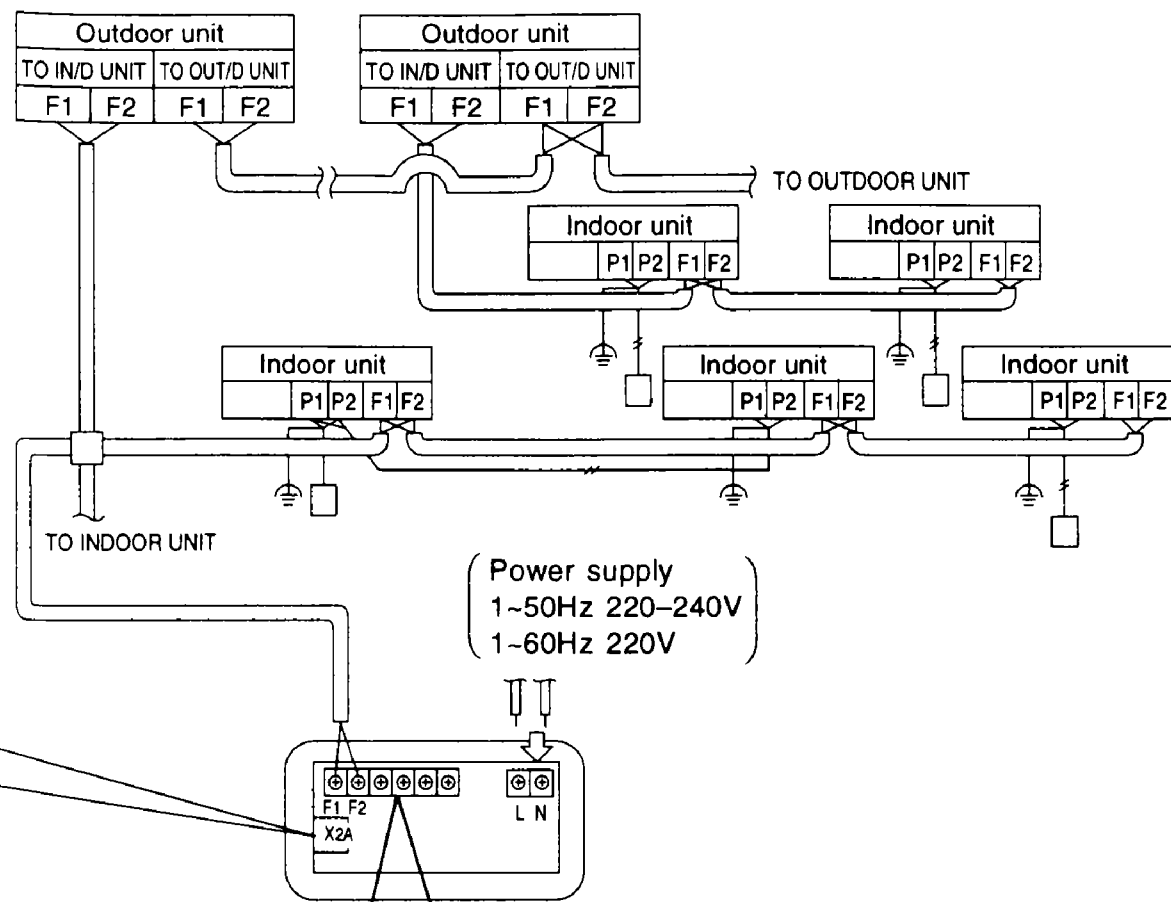

### Connector for unification adaptor for computerized control (X2A)

Used when connecting unification adaptor for computerized control (DCS302A52/ optional accessory). For details, refer to the installation manual of the unification adaptor for computerized control.

### CONTROL TERMINAL STRIP

\* 1 For connecting indoor unit (F1, F2)

\* 2 Forced OFF input (T1, T2)

While the forced OFF input (no voltage contactor, for micro current) is ON (energized), all the connected indoor units are stopped and can not be operated.

Use only contactors which guarantee the minimum applicable load  $\approx 16V, 10mA$ .

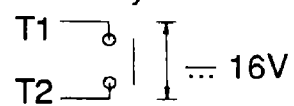

NOTE) Use instantaneous contactor of over 200msec. energizing time, when necessary.

\* 3 For schedule timer (D1, D2)

Power can be supplied to the schedule timer (DST301B61) separately sold. For details, refer to the installation manual of the schedule timer.

Wire \* 2 and \* 3 only when necessary.

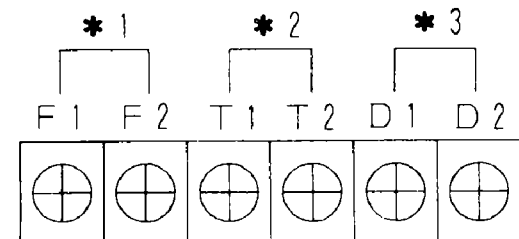

(NOTE)

Do not connect the power supply wiring (220 to 240V) to the control terminal strip. If connected by mistake, it may damage or burn electrical parts of optional controllers for centralized control and indoor unit. It may result in serious danger. Be sure to check wirings before turning the power ON.

## 6. Check this before performing a test run

Before performing checks, be sure to fill out the below sheet and give the building manager a copy. Explain to the him/her that keeping them in a handy safe place will enable faster response by aftercare service.

- System diagram (with control wiring and setting switches marked)
- Piping diagram (with refrigerant and drain pipe marked)
- Wiring diagram (with breaker locations marked)

NOTE: Keep system codes consistent.

Before performing a test run, check the following items.

Check item	Check method and criterion	Pass/Fail
1. Check drain piping is properly sloped.	<ul style="list-style-type: none"> <li>• Drain piping gradient should be 1:100 or more.</li> <li>• Add water to one of the indoor units and check for leaks and blockages in the system. Check the same amount of water you added is drained out.</li> </ul>	
2. Check wiring connections	<ul style="list-style-type: none"> <li>• Check wiring is as shown on the system diagram.</li> <li>• Check wiring is as shown on the power supply wiring diagram.</li> </ul>	
3. Check switch settings.	<ul style="list-style-type: none"> <li>• Check settings are as indicated on the system diagram.</li> </ul>	
4. Check breaker capacity.	<ul style="list-style-type: none"> <li>• Refer to the installation manual and system reference materials.</li> </ul>	
5. Charge each outdoor unit with additional refrigerant.	<ul style="list-style-type: none"> <li>• Mark pipe length and the refrigerant charge at prescribed locations.</li> <li>* Refer to the appendix.</li> </ul>	

— **Make a copy for  
each system. —**  
**p.87 ~ 91**

# Precautions in charging refrigerant

## 1. Mark the model number of the indoor unit and its location.

This information is needed for aftercare service.

Indoor unit model number	1	2	3	4	5	6	7	8
Location								

## 2. Calculating refrigerant charge

- Calculate the charge of refrigerant needed as described below, and add accordingly.
- The equipment can be operated as is without further charging if calculations come to 0 or less.
- Record your calculations for use by aftercare service.

Additional charge	=	Total length of liquid line piping (φ 12.7) × 1	+	Total length of liquid line piping (φ 9.5) × 0.05
kg		(m) × 0.1		(m) × 0.05
				Total length of liquid line piping (φ 6.4) × 0.025
				(m) × 0.025 - 2

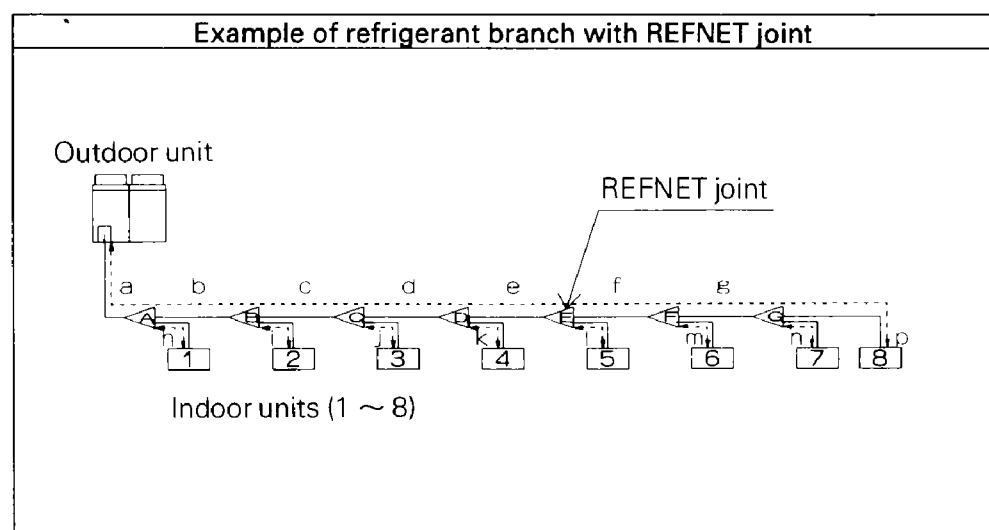

a : φ 12.7 × 30m	i : φ 6.4 × 5m
b : φ 12.7 × 5m	j : φ 6.4 × 5m
c : φ 12.7 × 5m	k : φ 6.4 × 5m
d : φ 12.7 × 5m	l : φ 9.5 × 5m
e : φ 9.5 × 3m	m : φ 6.4 × 5m
f : φ 9.5 × 2m	n : φ 6.4 × 5m
g : φ 9.5 × 5m	p : φ 6.4 × 5m
h : φ 9.5 × 5m	

$$R = \frac{45 \times 0.1}{a+b+c+d} + \frac{20 \times 0.05}{e+f+g+h+i} + \frac{30 \times 0.025}{i+j+k+m+n+p} - 2 = 4.25$$

4.3kg

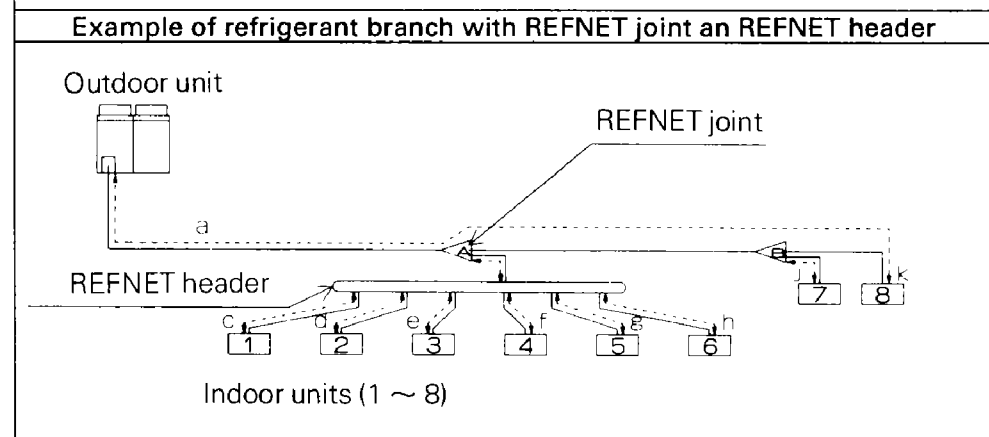

a : φ 12.7 × 30m	g : φ 6.4 × 10m
b : φ 12.7 × 10m	h : φ 6.4 × 20m
c : φ 9.5 × 10m	i : φ 9.5 × 10m
d : φ 6.4 × 10m	j : φ 9.5 × 10m
e : φ 6.4 × 10m	k : φ 6.4 × 9m
f : φ 6.4 × 10m	

$$R = \frac{40 \times 0.1}{a+b} + \frac{30 \times 0.05}{c+i+j} + \frac{69 \times 0.025}{d+e+f+g+h+i} - 2 = 5.225$$

5.2kg

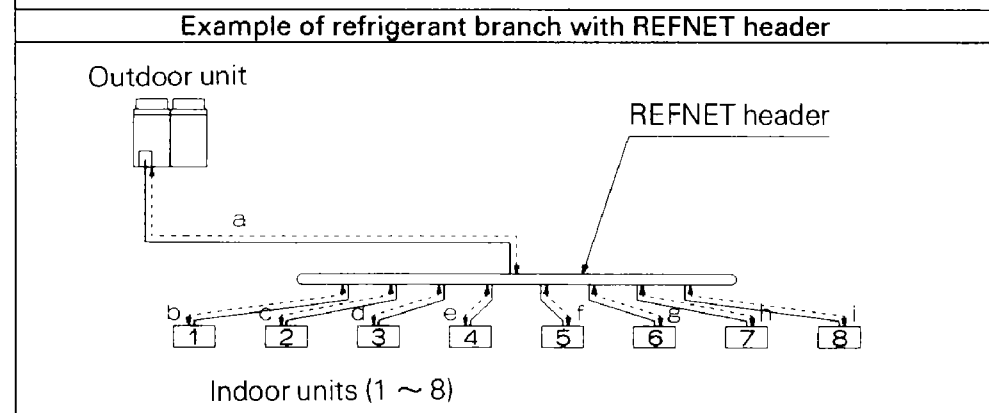

a : φ 12.7 × 40m	f : φ 6.4 × 23m
b : φ 9.5 × 20m	g : φ 6.4 × 20m
c : φ 9.5 × 10m	h : φ 6.4 × 20m
d : φ 6.4 × 10m	i : φ 6.4 × 30m
e : φ 6.4 × 20m	

$$R = \frac{40 \times 0.1}{a} + \frac{30 \times 0.05}{b+c} + \frac{123 \times 0.025}{d+e+f+g+h+i} - 2 = 6.575$$

6.6kg

## 3. Full refrigerant recharging

The amount of refrigerant needed to completely recharge the system equals to that of the refrigerant charge at factory set (marked on name plate) plus the above additional charge.

## 4. Extracting refrigerant

Open the stop valves on both the gas line and liquid line, and extract the refrigerant from the service ports.



# VRV system check list

Checked date: \_\_\_\_\_

Delivered date: \_\_\_\_\_

Check ordered date: \_\_\_\_\_

Customer		System name	
----------	--	-------------	--

<Outdoor unit>

Location	Model name	Serial No.

<Indoor unit>

	Location	Model	Serial No.	Centralized control group No.
A				
B				
C				
D				
E				
F				
G				
H				
I				
J				
K				
L				
M				
N				
O				
P				

<Field Settings>

C/H SELECT (MODE 1)			C/H SELECT (SS1)			Low noise operation			Sequential start	
IND	MASTER	SLAVE	IN / D	OUT / D		ON	OFF	ON	OFF	
TC			TE			Deforost setting			Additional refrigerant charge	
H	M	L	H	M	L	H	M	L	kg	

Remarks

Installed by \_\_\_\_\_ Checked by \_\_\_\_\_

		INSPECTION ITEM	INSPECTION METHOD	STANDARD	ACTUAL MEASUREMENT				Judgement				
Prior to power on	Outdoor unit	Breaker capacity	Visual inspection	Specified capacity	A								
		Refrigerant piping system	Gas leak detector	No leakage	YES		NO						
		Heat exchanger	Visual inspection	No clogging or damage	Good		Bad						
		Terminal connection	Screwdriver, etc.	No loosening	Good		Bad						
		Fan motor insulation	500V mega tester	Over 1MΩ	MΩ								
		Compressor insulation	500V mega tester	Over 1MΩ	No. 1	MΩ	No. 2	MΩ					
		Installation condition	Visual inspection	Short-circuit, etc.	Good		Bad						
	Indoor unit	Refrigerant piping system	Gas leak detector	No leakage	Room A	G/B	Room B	G/B	Room C	G/B	Room D	G/B	
					Room E	G/B	Room F	G/B	Room G	G/B	Room H	G/B	
					Room I	G/B	Room J	G/B	Room K	G/B	Room L	G/B	
					Room M	G/B	Room N	G/B	Room O	G/B	Room P	G/B	
		Air filter	Visual inspection	No clogging or damage	Room A	G/B	Room B	G/B	Room C	G/B	Room D	G/B	
					Room E	G/B	Room F	G/B	Room G	G/B	Room H	G/B	
					Room I	G/B	Room J	G/B	Room K	G/B	Room L	G/B	
Room M					G/B	Room N	G/B	Room O	G/B	Room P	G/B		
Heat exchanger		Visual inspection	No clogging or damage	Room A	G/B	Room B	G/B	Room C	G/B	Room D	G/B		
				Room E	G/B	Room F	G/B	Room G	G/B	Room H	G/B		
				Room I	G/B	Room J	G/B	Room K	G/B	Room L	G/B		
				Room M	G/B	Room N	G/B	Room O	G/B	Room P	G/B		
Fan motor insulation		500V mega tester	Over 1MΩ	Room A	MΩ	Room B	MΩ	Room C	MΩ	Room D	MΩ		
				Room E	MΩ	Room F	MΩ	Room G	MΩ	Room H	MΩ		
				Room I	MΩ	Room J	MΩ	Room K	MΩ	Room L	MΩ		
				Room M	MΩ	Room N	MΩ	Room O	MΩ	Room P	MΩ		
Aux. heater insulation		500V mega tester	Over 1MΩ	Room A	MΩ	Room B	MΩ	Room C	MΩ	Room D	MΩ		
	Room E			MΩ	Room F	MΩ	Room G	MΩ	Room H	MΩ			
	Room I			MΩ	Room J	MΩ	Room K	MΩ	Room L	MΩ			
	Room M			MΩ	Room N	MΩ	Room O	MΩ	Room P	MΩ			
Installation condition	Visual inspection	Short-circuit, etc.	Room A	G/B	Room B	G/B	Room C	G/B	Room D	G/B			
			Room E	G/B	Room F	G/B	Room G	G/B	Room H	G/B			
			Room I	G/B	Room J	G/B	Room K	G/B	Room L	G/B			
			Room M	G/B	Room N	G/B	Room O	G/B	Room P	G/B			

		INSPECTION ITEM	INSPECTION METHOD	STANDARD	ACTUAL MEASUREMENT				Judgement			
After power on	Outdoor unit	Main power source voltage	Tester	±10% of rated voltage	V							
		Operation circuit voltage	Tester	±10% of rated voltage	V							
		Fan rotation direction	Visual inspection	Positive direction	Good		Bad					
		Fan noise and vibration	Listen and touch.	None	Good		Bad					
		Fan operating current	Clamp meter		A							
		Inlet air temperature	Thermometer	Temp. difference At cooling: 9-11°C At heating: 2-3.5°C	°C							
		Outlet air temperature	Thermometer		°C							
		Compressor suction pressure	Pressure gauge		INV.	kg/cm <sup>2</sup>	STD.	kg/cm <sup>2</sup>				
		Compressor discharge pressure	Pressure gauge		INV.	kg/cm <sup>2</sup>	STD.	kg/cm <sup>2</sup>				
		Compressor operating current	Clamp meter		INV.	A	STD.	A				
		Compressor frequency	LED display		INV.	Hz						
		Suction pipe temperature	Thermometer	3-15°C	No.1	°C	No.1	°C				
		Discharge pipe temperature	Thermometer	85-105°C	No.1	°C	No.1	°C				
	Crankcase heater	Touch by hand.	Should be heated.	No.1	Good	Bad	No.2	Good	Bad			
	Indoor unit	Power source voltage	Tester	±10% of rated voltage	Room A	V	Room B	V	Room C	V	Room D	V
					Room E	V	Room F	V	Room G	V	Room H	V
					Room I	V	Room J	V	Room K	V	Room L	V
					Room M	V	Room N	V	Room O	V	Room P	V
		Inlet air temperature	Thermometer	Temp. difference At cooling: 9-13°C At heating: 15-20°C	Room A	°C	Room B	°C	Room C	°C	Room D	°C
					Room E	°C	Room F	°C	Room G	°C	Room H	°C
Room I					°C	Room J	°C	Room K	°C	Room L	°C	
Room M					°C	Room N	°C	Room O	°C	Room P	°C	
Outlet air temperature		Thermometer	Room A	°C	Room B	°C	Room C	°C	Room D	°C		
			Room E	°C	Room F	°C	Room G	°C	Room H	°C		
			Room I	°C	Room J	°C	Room K	°C	Room L	°C		
			Room M	°C	Room N	°C	Room O	°C	Room P	°C		
Fan rotation direction		Visual inspection	Right direction	Room A	G/B	Room B	G/B	Room C	G/B	Room D	G/B	
				Room E	G/B	Room F	G/B	Room G	G/B	Room H	G/B	
				Room I	G/B	Room J	G/B	Room K	G/B	Room L	G/B	
				Room M	G/B	Room N	G/B	Room O	G/B	Room P	G/B	
Fan noise and vibration		Listen and touch.	None	Room A	G/B	Room B	G/B	Room C	G/B	Room D	G/B	
	Room E			G/B	Room F	G/B	Room G	G/B	Room H	G/B		
	Room I			G/B	Room J	G/B	Room K	G/B	Room L	G/B		
	Room M			G/B	Room N	G/B	Room O	G/B	Room P	G/B		
Fan operating current	Clamp meter	Room A	A	Room B	A	Room C	A	Room D	A			
		Room E	A	Room F	A	Room G	A	Room H	A			
		Room I	A	Room J	A	Room K	A	Room L	A			
		Room M	A	Room N	A	Room O	A	Room P	A			
(Remarks)												





Все каталоги и инструкции здесь:  
<https://sp>

**Все каталоги и инструкции здесь:** <https://splitsystema48.ru/instrukcii-po-ekspluatacii-kondicionerov.html>

Все каталоги и инструкции здесь: <https://splitsystema48.ru/instrukcii-po-ekspluatacii-kondicionerov.html>



# ***VRV* PLUS Series**

# 1. Outline of System

## Heat Pump and Cooling Only System RX(Y)-K

Heat pump

[ L unit ] BL-K

Все каталоги и инструкции здесь: <https://splitsystema48.ru/instrukcii-po-ekspluatacii-kondicionerov.html>

Cooling only

[ C unit ] BC-K  
Inverter type outdoor unit RX-K  
Constant speed type outdoor unit RN-K

### Indoor unit connection capacity

Outdoor unit total capacity of 50 ~ 130%

### No. of connectable indoor units

RX(Y) 16K ~ 20K: Max. 20 units

RX(Y) 24K ~ 30K: Max. 30 units

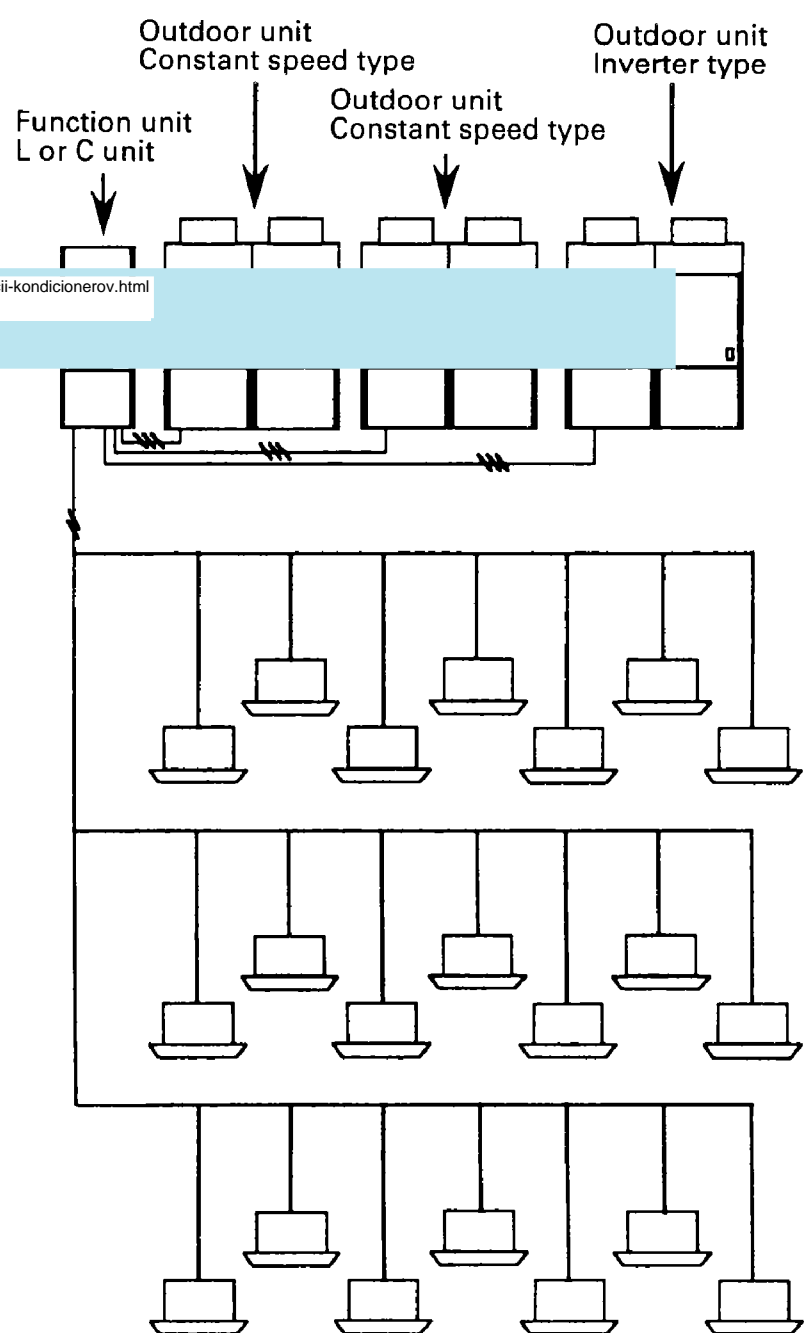

## Heat-recovery system REY-K

Function unit BR-K  
Inverter outdoor unit RXY-K  
Constant speed outdoor unit RNY-K

### Indoor unit connection capacity

Outdoor unit total capacity of 50 ~ 130%

### No. of connectable indoor units

REY 16K ~ 20K: Max. 20 units

REY 24K ~ 30K: Max. 30 units

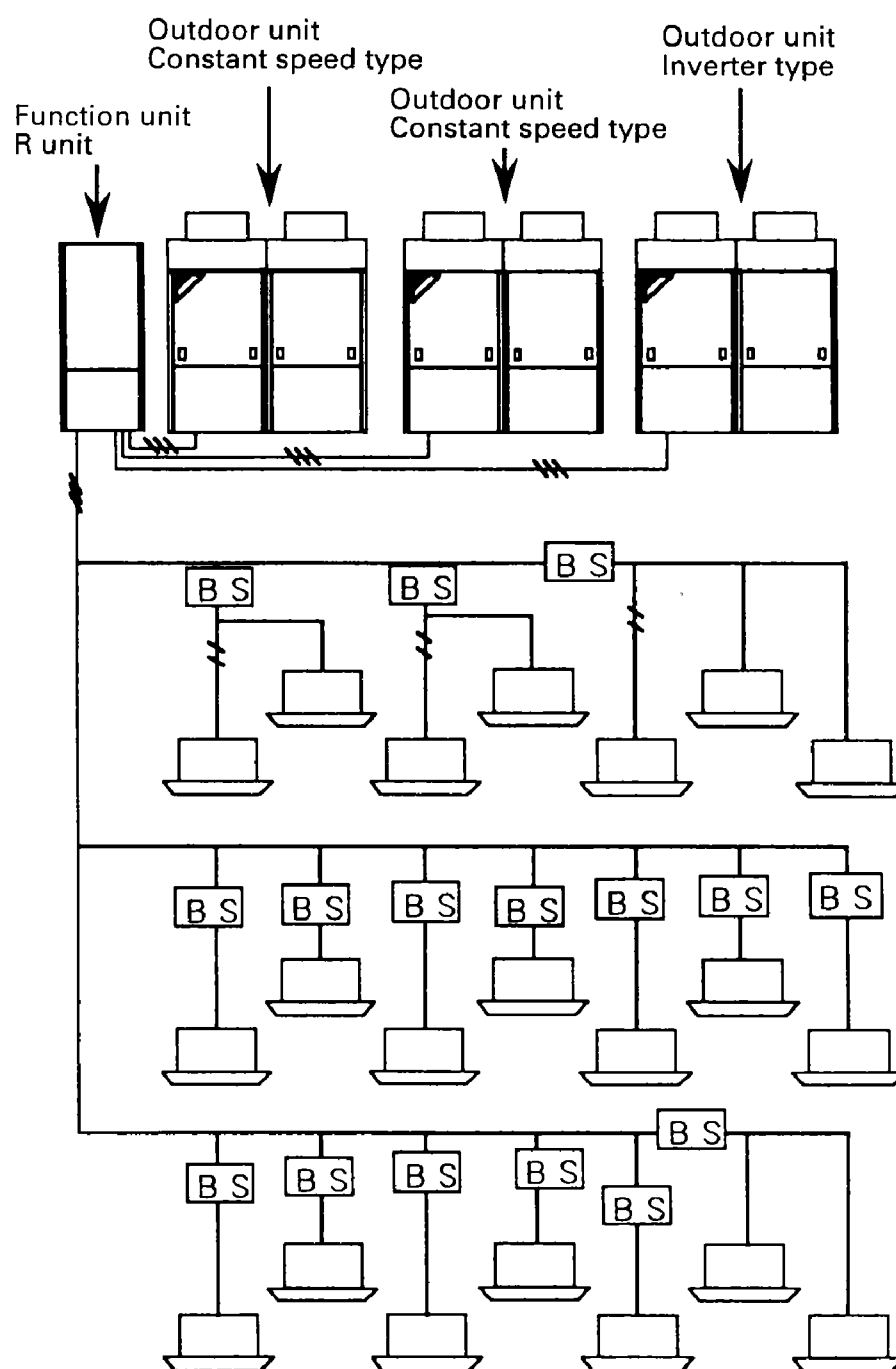

## 2. Allowable Piping Length

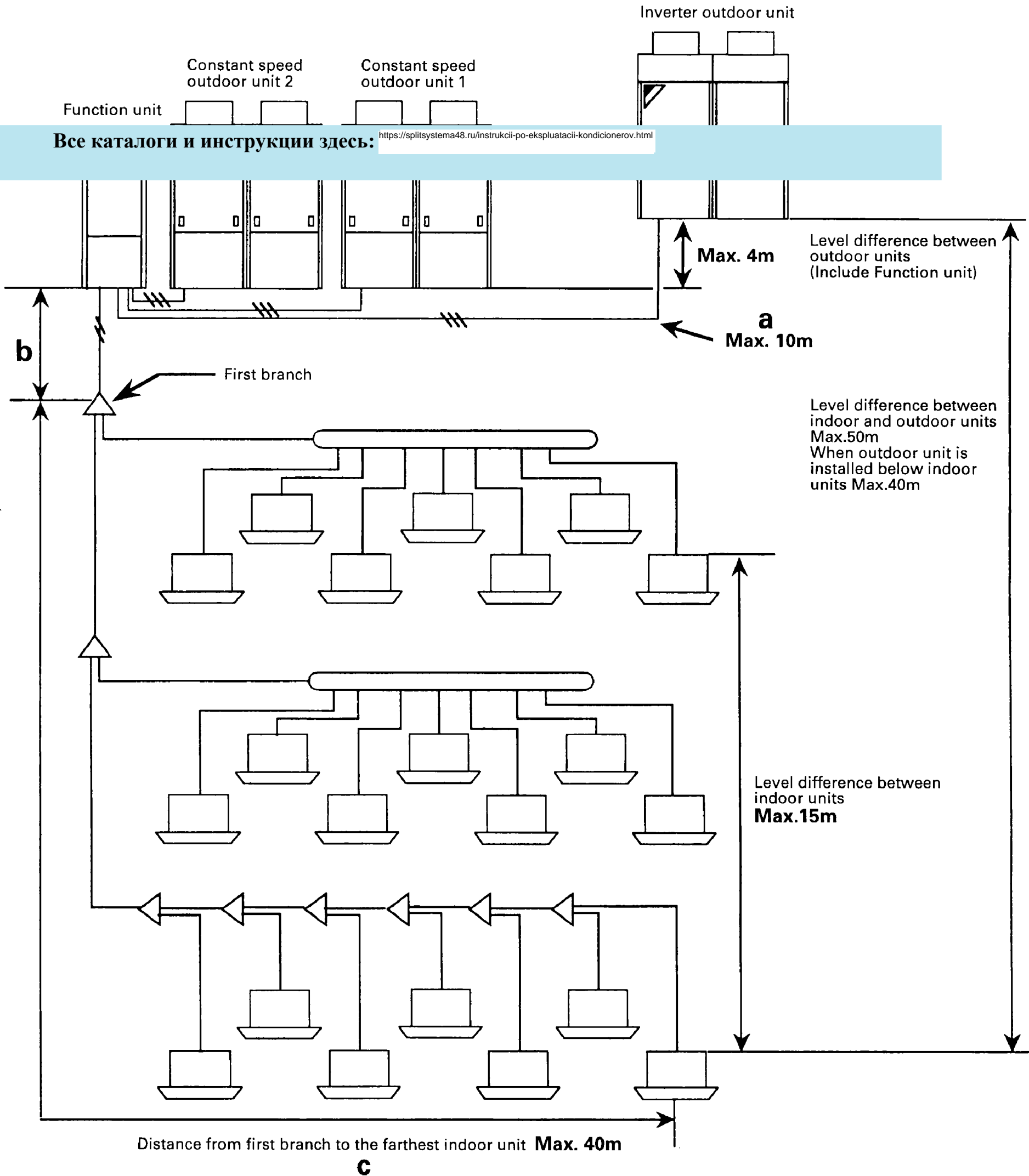

### Points of piping design

1.  $a+b+c=100m$
2. Level difference between outdoor units which function unit is included.  $\leq 4 m$
3. Piping distance between function unit and the farthest outdoor unit  $\leq 10 m$
4. Piping distance between first branch and the farthest indoor unit  $\leq 40 m$
5. Level difference between indoor units  $\leq 15 m$
6. Level difference between indoor and outdoor unit  $\leq 50 m$   
(Level difference is lower than 40 m when outdoor unit is installed below indoor unit.)
7. Refnet joint and header are not downstream for first installed Refnet header.

### 3. How to Install Outdoor Units and Function Unit

#### Example layout

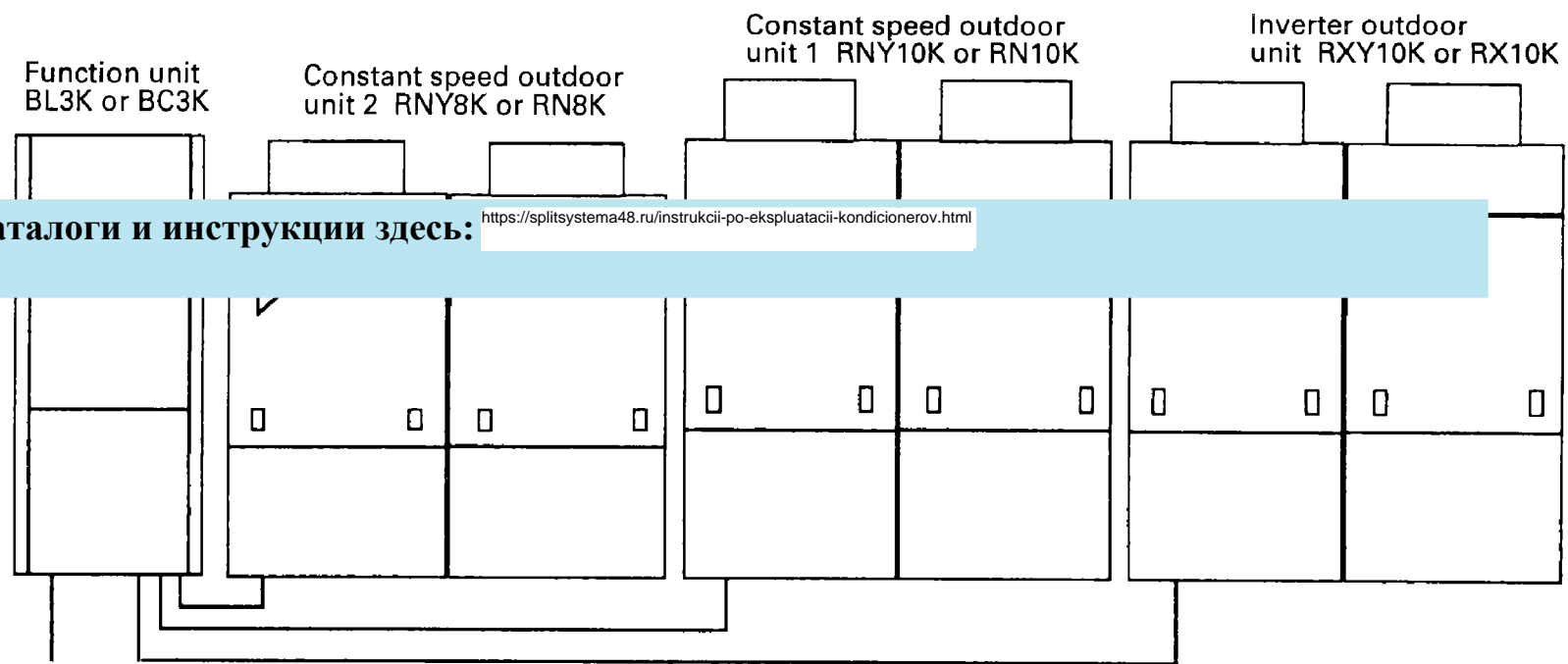

Capacity of constant speed outdoor unit 2 should be less than or equal to constant speed outdoor unit 1, which in turn should be less than or equal to inverter outdoor unit. The example given above is one example of a Heat pump system. Similar layouts are used for Heat-recovery systems.

#### Precautions for setup

Because pipes do not cross each other, arranging function units and outdoor units as shown below facilitates installation work and presents a better appearance.

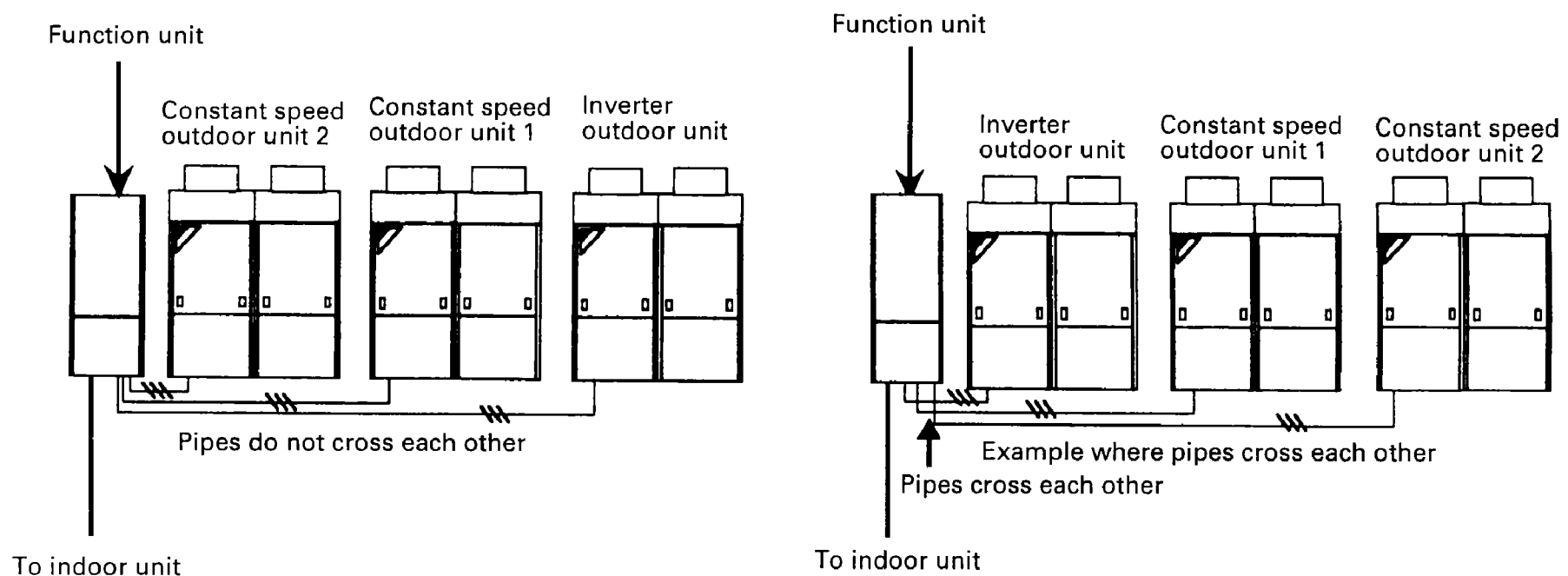

- Be sure to connect inverter and constant speed outdoor units to the specified position of the function unit. Failing to do so could result in equipment damage.

#### Work points

1. Some commercially available vibration isolation frames do not allow for piping from the bottom of outdoor units.
2. If applying vibration isolation rubber, spread it longways rather than in the four corners. The thickness of the rubber provides an effect similar to that of a pit foundation, and will cause the frame to sag in the middle.
3. The capacity of constant speed outdoor unit 1 should be at least as large as that of constant speed outdoor unit 2.

## 4. Unit Combinations

### (1) Heat pump system

Model ※1	Function unit	Combination		No. of indoor unit to be connected
		Inverter	Constant speed	
RXY16K	BL2K	RXY8K	RNY8K	20
RXY18K		RXY10K	RNY8K	
RXY24K	BL3K	RXY8K	RNY8K × 2	30
RXY26K		RXY10K	RNY8K × 2	
RXY28K		RXY10K	RNY8K × 1 RNY10K × 1	
RXY30K		RXY10K	RNY10K × 2	

Все каталоги и инструкции здесь: <https://splitsystema48.ru/instrukcii-po-ekspluatacii-kondicionerov.html>

### (2) Cooling only system

Model ※1	Function unit	Combination		No. of indoor unit to be connected
		Inverter	Constant speed	
RX16K	BC2K	RX8K	RN8K	20
RX18K		RX10K	RN8K	
RX20K		RX10K	RN10K	
RX24K	BC3K	RX8K	RN8K × 2	30
RX26K		RX10K	RN8K × 2	
RX28K		RX10K	RN8K × 1 RN10K × 1	
RX30K		RX10K	RN10K × 2	

### (3) Heat-recovery system

Model ※1	Function unit	Combination		No. of indoor unit to be connected
		Inverter	Constant speed	
REY16K	BR2K	RXY8K	RNY8K	20
REY18K		RXY10K	RNY8K	
REY20K		RXY10K	RNY10K	
REY24K	BR3K	RXY8K	RNY8K × 2	30
REY26K		RXY10K	RNY8K × 2	
REY28K		RXY10K	RNY8K × 1 RNY10K × 1	
REY30K		RXY10K	RNY10K × 2	

※1 Combination Model name

# 5. Selection of Refrigerant Pipe

## Capacity of indoor unit and size of refrigerant pipe (G)

Class		20	25	32	40	50	63	80	100	125	200	250
Cooling Capacity (19.5 °CWB)	kcal/h	2,000	2,500	3,150	4,000	5,000	6,300	8,000	10,000	12,500	20,000	25,000
	Btu/h	7,900	9,900	12,500	15,900	19,900	25,000	31,800	39,700	49,600	79,000	99,000
	kW	2.3	2.9	3.7	4.7	5.9	7.5	9.5	11.9	14.7	23.0	28.8
Все каталоги и инструкции здесь: <a href="https://splitsystema48.ru/instrukcii-po-ekspluatacii-kondicionerov.html">https://splitsystema48.ru/instrukcii-po-ekspluatacii-kondicionerov.html</a>												
											22.4	28.0
Heating Capacity	kcal/h	2,200	2,800	3,400	4,300	5,400	6,900	8,600	10,800	13,800	21,500	27,000
	Btu/h	8,500	10,900	13,600	17,000	21,500	27,300	34,100	42,700	54,600	85,300	107,500
	kW	2.5	3.2	4.0	5.0	6.3	8.0	10.0	12.5	16.0	25.0	31.5
Liquid pipes		φ 6.4					φ 9.5			φ 9.5	φ 12.7	φ 12.7
Gas pipes		φ 12.7					φ 15.9			φ 19.1	φ 25.4	φ 28.6

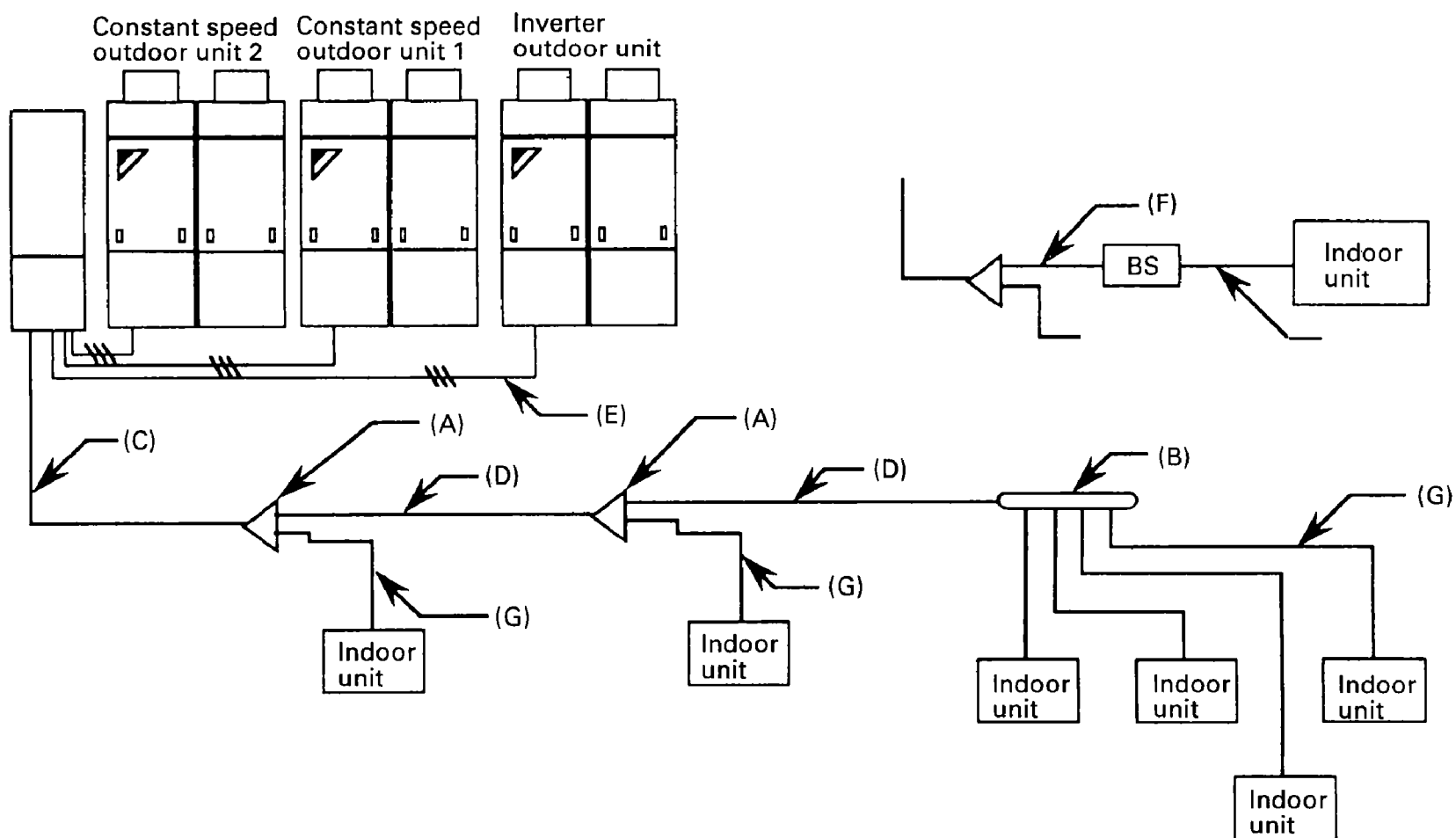

### (1) Heat pump and Cooling only system

- Selection of branch kit... REFNET joint (A) and REFNET beader (B)

Capacity	REFNET joint (A)	REFNET header (B)
Less than 100	KHRJ26K11T	KHRJ26K11H (Max. 4 branches)
100 or more to 160 (160 excluded)	KHRJ26K18T	KHRJ26K18H (Max. 6 branches)
160 or more to 330 (330 excluded)	KHRJ26K37T	KHRJ26K37H (Max. 8 branches)
330 or more to 640 (640 excluded)	KHRJ26K40T + KHRJ26K40TP ※Note 1	KHRJ26K40H (Max. 8 branches) + KHRJ26K40HP ※Note 1
640 or more	KHRJ26K75T + KHRJ26K75TP	※Note 2

Note 1. KHRJ26K40/75TP or KHRJ26K40HP are pipe size reducer.

Note 2. For system with total capacity of 640 and over, connect REFNET header after the REFNET joint branch kit.

- Between L-Unit and first branch kit (C)

Applicable model	Pipe size (out. dia. × min. wall thickness)	
	Liquid pipe	Gas pipe (main)
RX(Y)16K	φ 15.9×t1.0	φ 34.9×t1.3
RX(Y)18~20K	φ 19.1×t1.0	φ 34.9×t1.3
RX(Y)24K	φ 19.1×t1.0	φ 41.3×t1.7
RX(Y)26~30K	φ 22.2×t1.2	φ 41.3×t1.7

- Between branches kit (D)

Total capacity index of indoor unit after branch	Pipe size (out. dia. × min. wall thickness)	
	Liquid pipe	Gas pipe
Below 100	φ 9.5×t0.8	φ 15.9×t1.0
100 to below 160	φ 9.5×t0.8	φ 19.1×t1.0
160 to below 330	φ 12.7×t0.8	φ 25.4×t1.2
330 to below 480	φ 15.9×t1.0	φ 34.9×t1.3
480 to below 640	φ 19.1×t1.0	φ 34.9×t1.3
640 and over	φ 19.1×t1.0	φ 41.3×t1.7



## (2) Heat-recovery system

### • Selection of branch kit... REFNET joint (A) and REFNET header (B)

Capacity	REFNET joint (A)	REFNET header (B)
Less than 160	KHRJ25K18T	KHRJ25K18H (Max.6 branches)
160 or more to 330 (330 excluded)	KHRJ25K37T	KHRJ25K38H (Max.8 branches)
340 or more	KHRJ26K75T + KHRJ26K75TP	KHRJ26K40HP ※Note 1
640 or more	KHRJ26K75T + KHRJ26K75TP	※NOTE 2

Все каталоги и инструкции здесь: <https://splitsystema48.ru/instrukcii-po-ekspluatacii-kondicionerov.html>

Notes 1. KHRJ26K40/75TP and KHRJ26K40HP are pipe size reducers.

Notes 2. For systems with a total capacity of 640 and over, connect REFNET header after the REFNET joint branch kit.

### • Between R-Unit and first branch kit (C)

Applicable model	Pipe size (out. dia. × min. wall thickness)		
	Liquid pipe	Suction gas pipe	Discharge gas pipe
RXY16K	φ 15.9×t1.0	φ 34.9×t1.3	φ 25.4×t1.2
RXY18~20K	φ 19.1×t1.0	φ 34.9×t1.3	φ 25.4×t1.2
RXY24K	φ 19.1×t1.0	φ 41.3×t1.7	φ 28.6×t1.2
RXY26K	φ 22.2×t1.2	φ 41.3×t1.7	φ 28.6×t1.2
RXY28~30K	φ 22.2×t1.2	φ 41.3×t1.7	φ 34.9×t1.3

### • Between branch kit (D) or BS unit and branch kit (F)

Total capacity index of indoor unit after branch	Pipe size (out. dia. × min. wall thickness)( :mm)		
	Liquid pipe	Suction gas pipe	Discharge gas pipe
* Below 50	φ 6.4×t0.8	φ 12.7×t0.8	φ 9.5×t0.8
50 to below 100	φ 9.5×t0.8	φ 15.9×t1.0	φ 12.7×t0.8
100 to below 160	φ 9.5×t0.8	φ 19.1×t1.0	φ 15.9×t1.0
160 to below 330	φ 12.7×t0.8	φ 25.4×t1.2	φ 19.1×t1.0
330 to below 480	φ 15.9×t1.0	φ 34.9×t1.3	φ 25.4×t1.2
480 to below 640	φ 19.1×t1.0	φ 34.9×t1.3	φ 25.4×t1.2
640 to below 700	φ 19.1×t1.0	φ 41.3×t1.7	φ 25.4×t1.2
700 and over	φ 19.1×t1.0	φ 41.3×t1.7	φ 34.9×t1.3

## (3) Heat pump system, Cooling only system and Heat-recovery system

### • Between R unit / L unit and outdoor unit (E)

	Inverter		Constant speed	
	RX(Y)8K	RX(Y)10K	RN(Y)8K	RN(Y)10K
Liquid pipe	12.7		12.7	
Gas pipe	25.4	28.6	25.4	28.6
Pressure equalizing pipe	19.1		19.1	

Select piping size in accordance with the size of the outdoor unit. Change the size at the connection section of the R unit/ L unit. (Odd-sized connection piping is attached to the outdoor unit side.)

## 6. Nitrogen Replacement

### NOTE

Before brazing refrigerant piping, you should blow nitrogen gas through the piping to expel air from the piping. If you braze the piping without doing so, a large amount of oxide film develops inside the piping, and could cause system failure.

### Procedure

Все каталоги и инструкции здесь: <https://splitsystema48.ru/instrukcii-po-ekspluatacii-kondicionerov.html>

hoses using the

- Using the reducing valve, blow the nitrogen gas through the refrigerant piping. (Set the pressure of the nitrogen gas to about 0.2 kg/cm<sup>2</sup>.)
- After replacing air with nitrogen gas, continue to blow nitrogen gas through the piping while brazing.

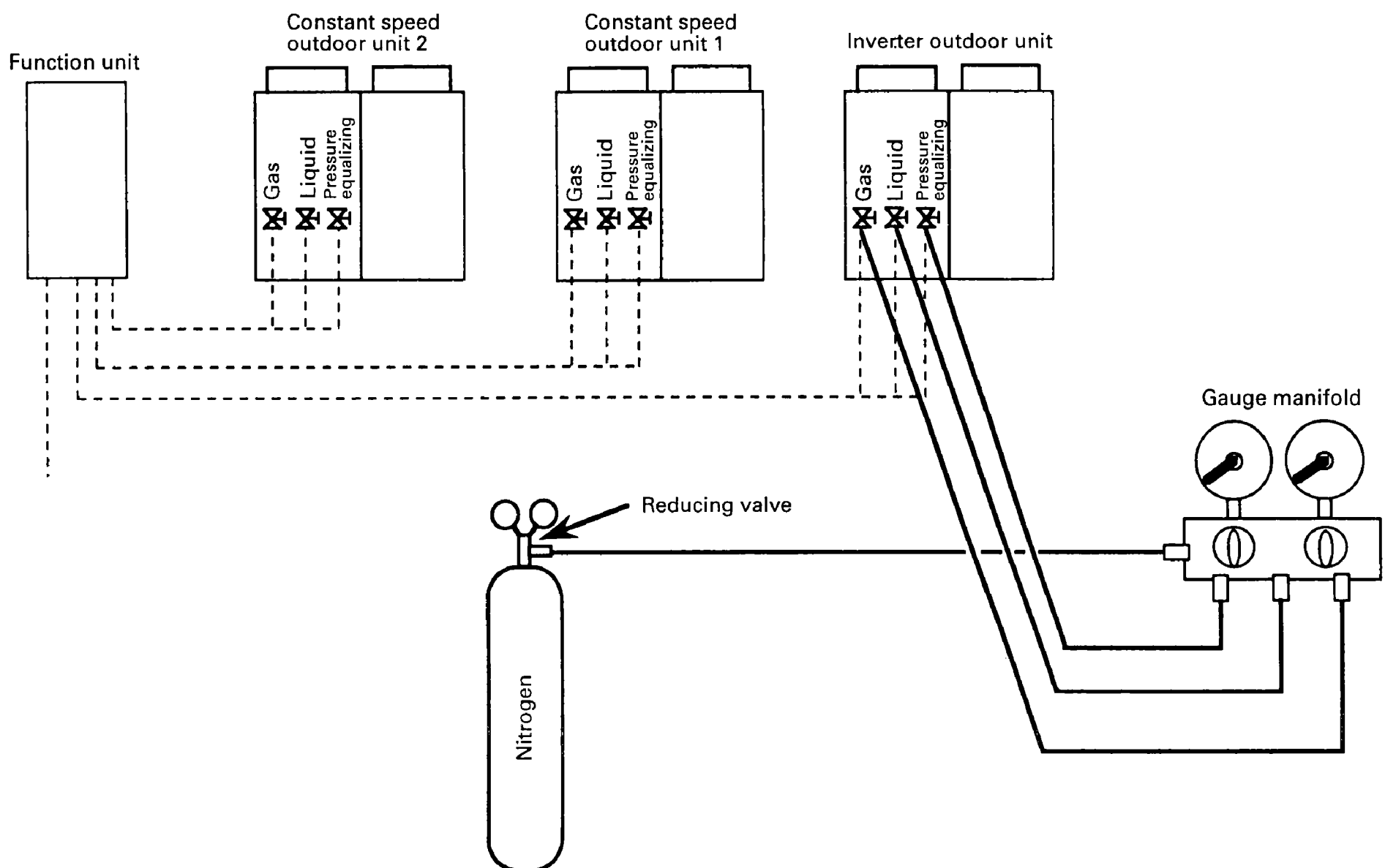

In addition to the method given above, you can also carry out nitrogen exchange by directly connecting the pipe from nitrogen cylinder to the refrigerant piping. Select the method that best suits the site.

### Work points

- If brazing while blowing nitrogen gas through the refrigerant piping, you should use a reducing valve to prevent pinholes caused by excessively high pressure.
- If brazing piping between outdoor and function units, change the connection of the gauge manifold in order.
- If brazing piping between outdoor and function units, leave the nitrogen connected to the last outdoor unit.

## 7. Brazing

The VRV Plus Series uses a wide range of piping sizes. You should therefore be careful when selecting the nozzle tip. If a small nozzle tip is used for brazing piping of large diameters such as  $\phi 38.1$  and  $\phi 44.5$ , brazing flow becomes poor.

**Table 1: Correlation of nozzle tip and size of refrigeration piping**

Piping size	Nozzle tip No.							Brazing filler diameter $\phi$	
	1	2	3	4	5	6	7	2.4	3.2
9.53									
12.7									
15.9									
19.1									
22.2									
25.4									
31.8									
38.1									
44.5									

NOTE: The values in the table above are for type B torch (French).

### Refrigerant piping brazing order

The task of connecting piping to the function unit (L/R unit) is facilitated if done as shown in the figure below.

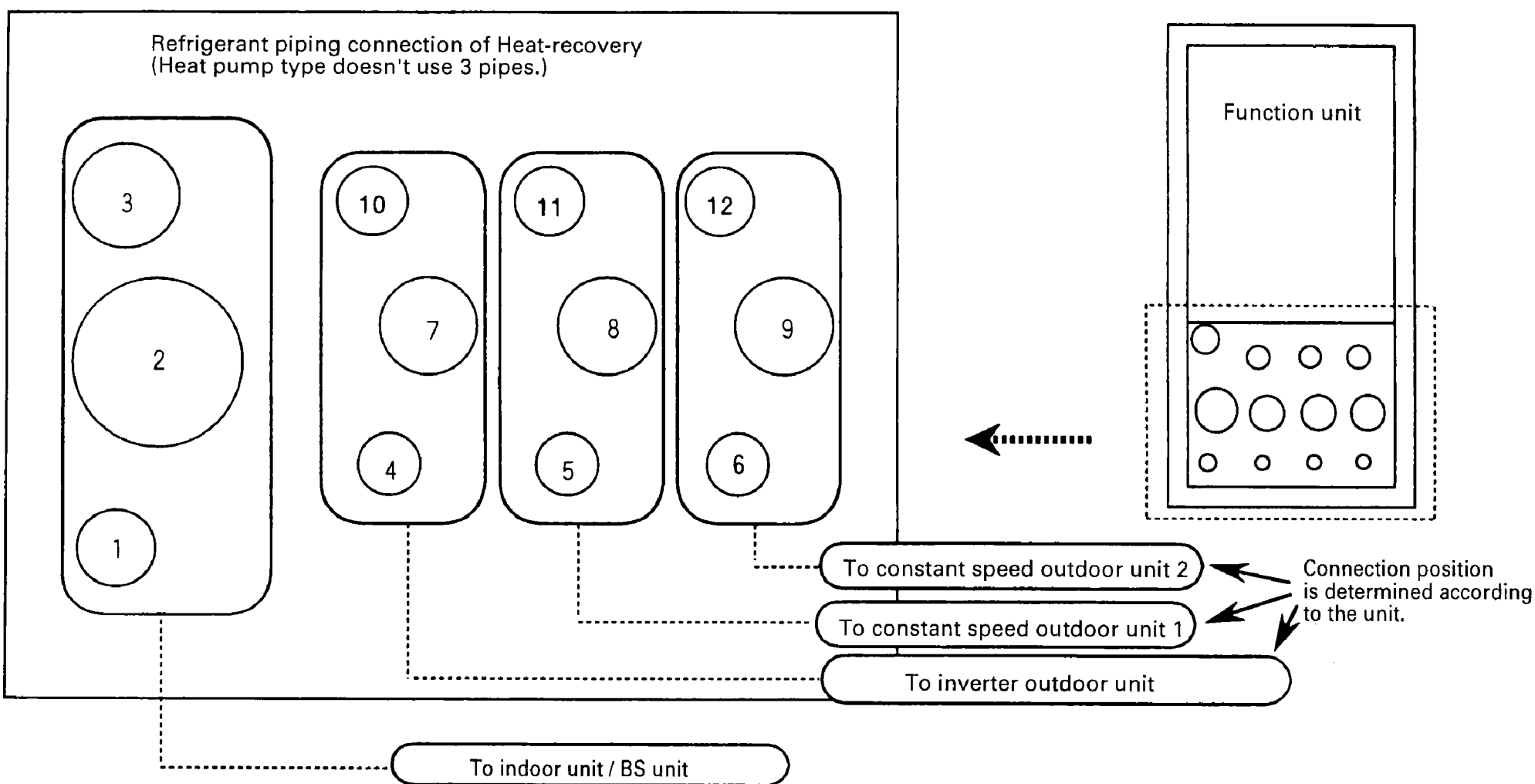

#### Work points

1. Replace air in the piping with nitrogen. (See the page about nitrogen replacement.)
2. Use a nozzle tip that matches the size of the refrigerant piping. See table 1.  
Gas leaks could result if you don't use the proper tip and brazing filler.
3. For order of piping brazing, see the figure above.
4. Brazing of indoor unit connecting piping can be facilitated by removing the piping from the outdoor unit.

## 8. Covering of Refrigerant Pipes

Covering is an extremely important operation as it prevents water, dirt or dust from getting inside the pipes. Moisture inside the pipes was a constant source of trouble in the past. The utmost care is required to nip this problem in the bud.

The end of each pieces of pipe must be covered. "Pinching" is the most effective method but "taping" is an simple alternative which may be used according to the work area and term of work.

Все каталоги и инструкции здесь: <https://splitsystema48.ru/instrukcii-po-ekspluatacii-kondicionerov.html>

Outdoors	3 months more	Pinching
	Less than 3 month	Pinching or taping
Indoors	Irrelevant	Pinching or taping

### ① Pinching method

The end of the copper pipe is squeezed together and the gap soldered.

### ② Taping method

The end of the copper pipe is covered with PVC tape.

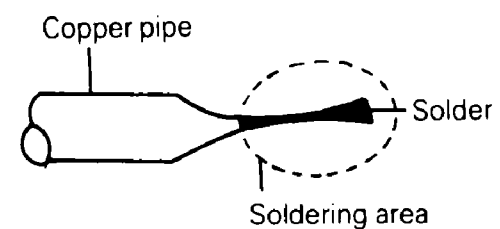

### <Taping method>

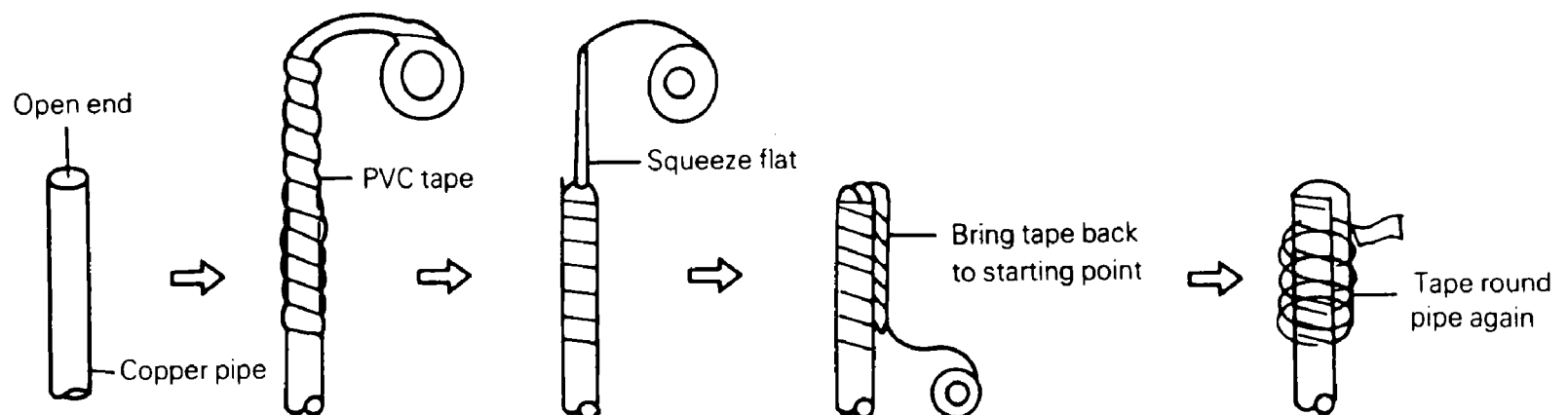

Particular care should be taken during the following operations:

- When passing copper pipe through a through hole (Dirt easily gets into the pipe).
- When copper pipe is pushed through to outside (Rainwater gets in )  
(Special care is needed when the pipes are standing vertically outside)

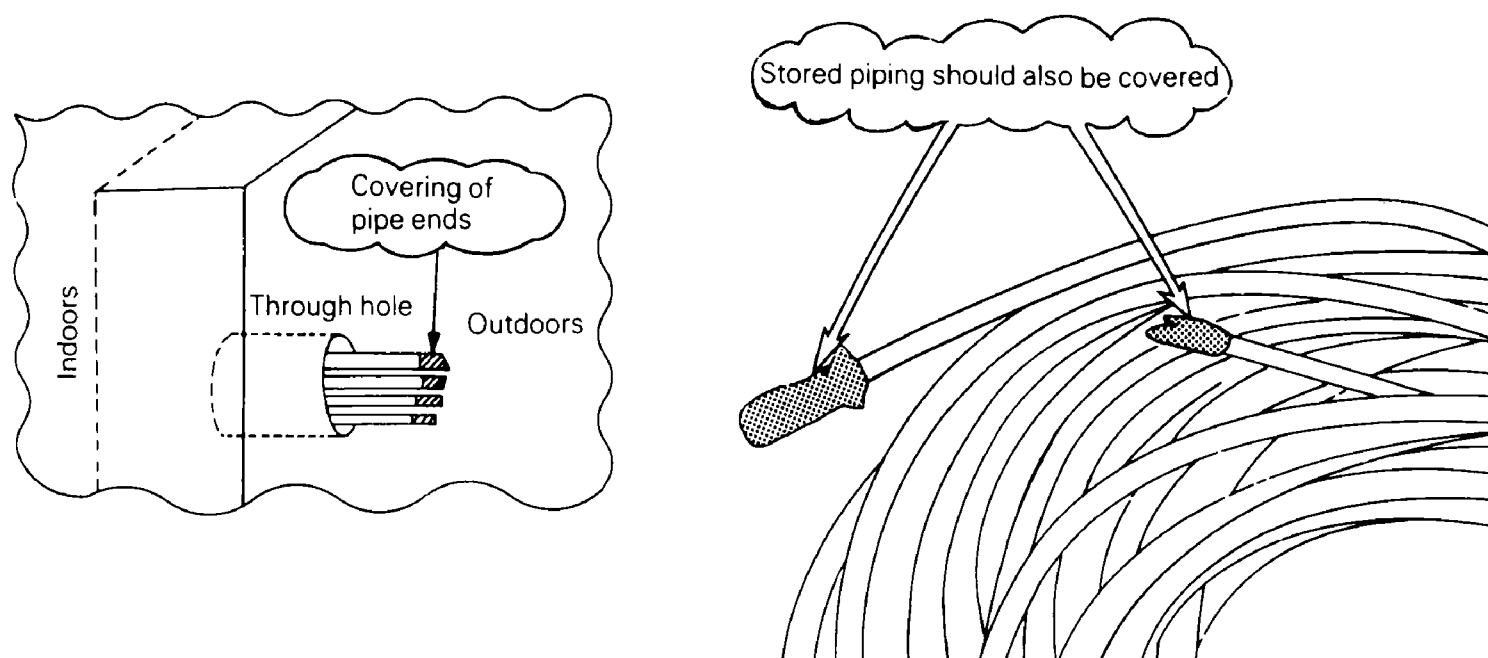

## 9. Flushing

Flushing is a method of cleaning extraneous matter out of pipes using pressurized gas.

[3 major effects]

- ① Removal of oxidation bubbles formed inside copper pipes when "nitrogen replacement is insufficient" during soldering work
- ② Removal of extraneous material and moisture from pipes when covering has been insufficient
- ③ Checks connections in pipes linking outdoor and indoor units (Both liquid and gas pipes)

Все каталоги и инструкции здесь: <https://splitsystema48.ru/instrukcii-po-ekspluatacii-kondicionerov.html>

- ① Set pressure regulator on nitrogen cylinder.  
 ※The gas used must be nitrogen.  
 (There is a danger of condensation if fluoron or carbon dioxide are used and oxygen carries the risk of explosions.)

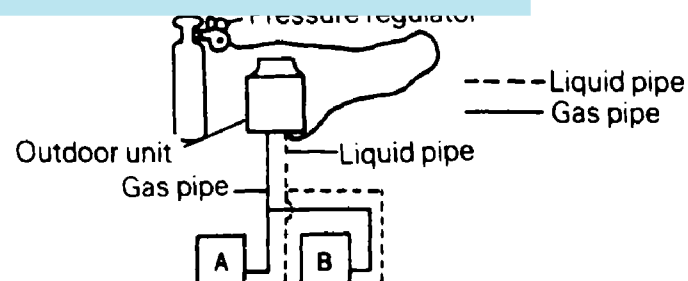

- ② Connect the charge hose from the pressure regulator to the service port on the liquid pipe side of the outdoor unit.

- ③ Fit blanking plugs to all indoor units (B) other than unit A.

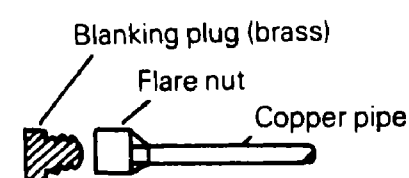

- ④ Open the main valve on the nitrogen cylinder and set the pressure regulator to 5 kg/cm<sup>2</sup>.

- ⑤ Check that the nitrogen is passing through the unit A liquid pipe.

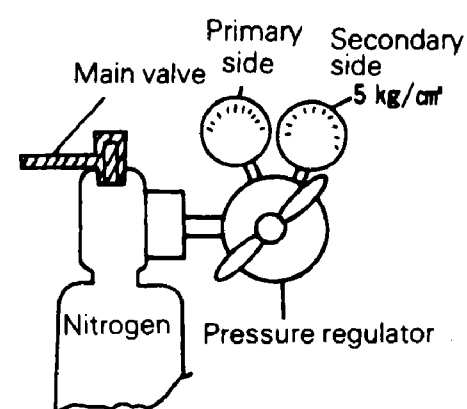

- ⑥ Flushing
  - Block the end of the pipe with the insulation of your hand.



- When the gas pressure becomes too great to contain remove insulation quickly.  
(First flush)



- Block the end of the pipe with insulation again.



(Carry out second flush)

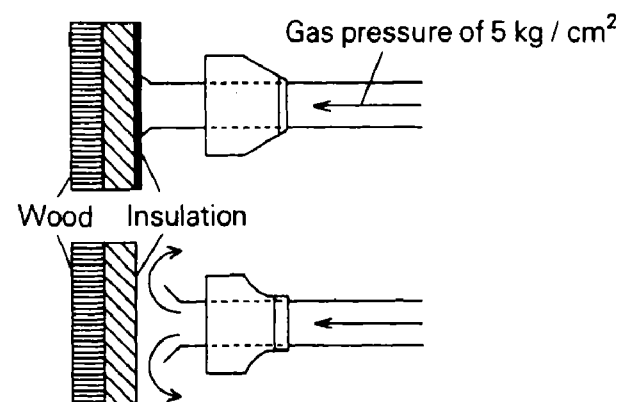

(The nature and amount of the extraneous material inside the pipe can be checked during flushing by placing a rag lightly over the end of the pipe. In the unlikely case that even a small quantity of moisture is found then the inside of the pipe should be dried out thoroughly.)

Action:

- (1) Flush the inside of the pipe with nitrogen gas.  
(Until such time as the moisture disappears.)
- (2) Carry out a thorough vacuum drying operation. (See page 43)

- ⑦ Close the main valve on the nitrogen cylinder.
- ⑧ Repeat the above operation for unit B.
- ⑨ When the liquid pipe operations have been completed then do the same with the gas pipes.

# 10. Air Tight Test

## How to connect the hose from gauge manifold

### 1. Heat pump system

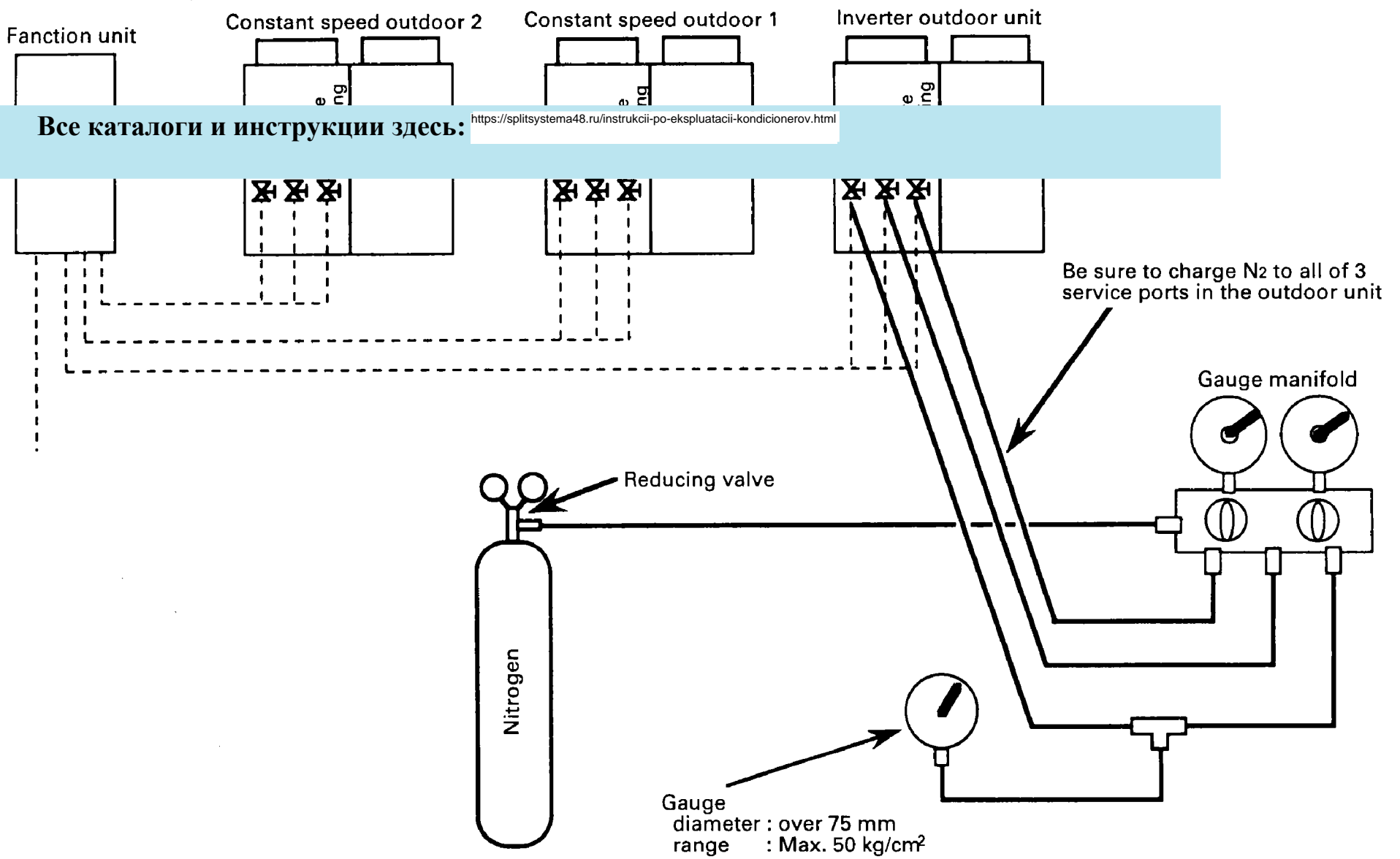

### 2. Heat-recovery system

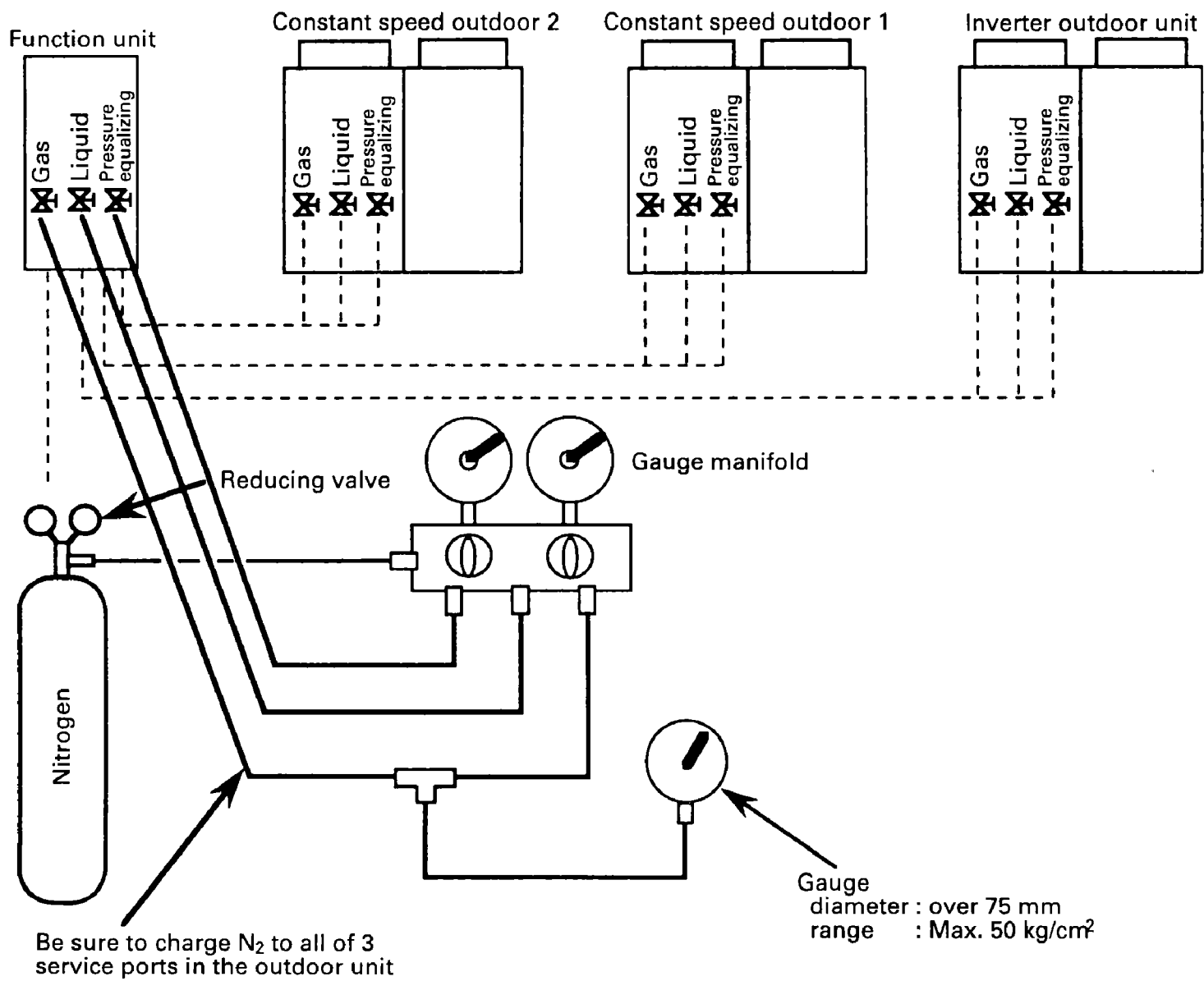

## Work order

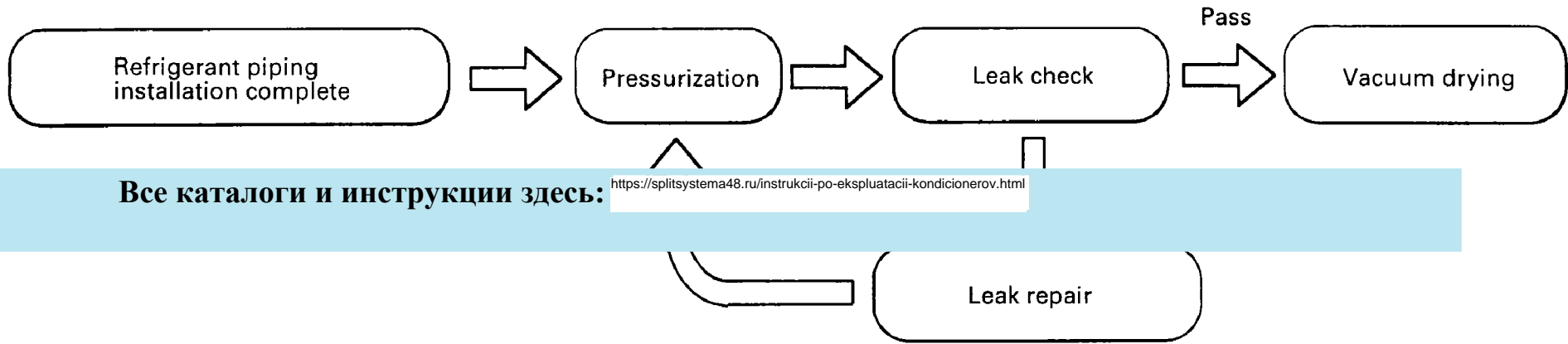

Все каталоги и инструкции здесь: <https://splitsystema48.ru/instrukcii-po-ekspluatacii-kondicionerov.html>

Perform the test with the following method and in the following order.

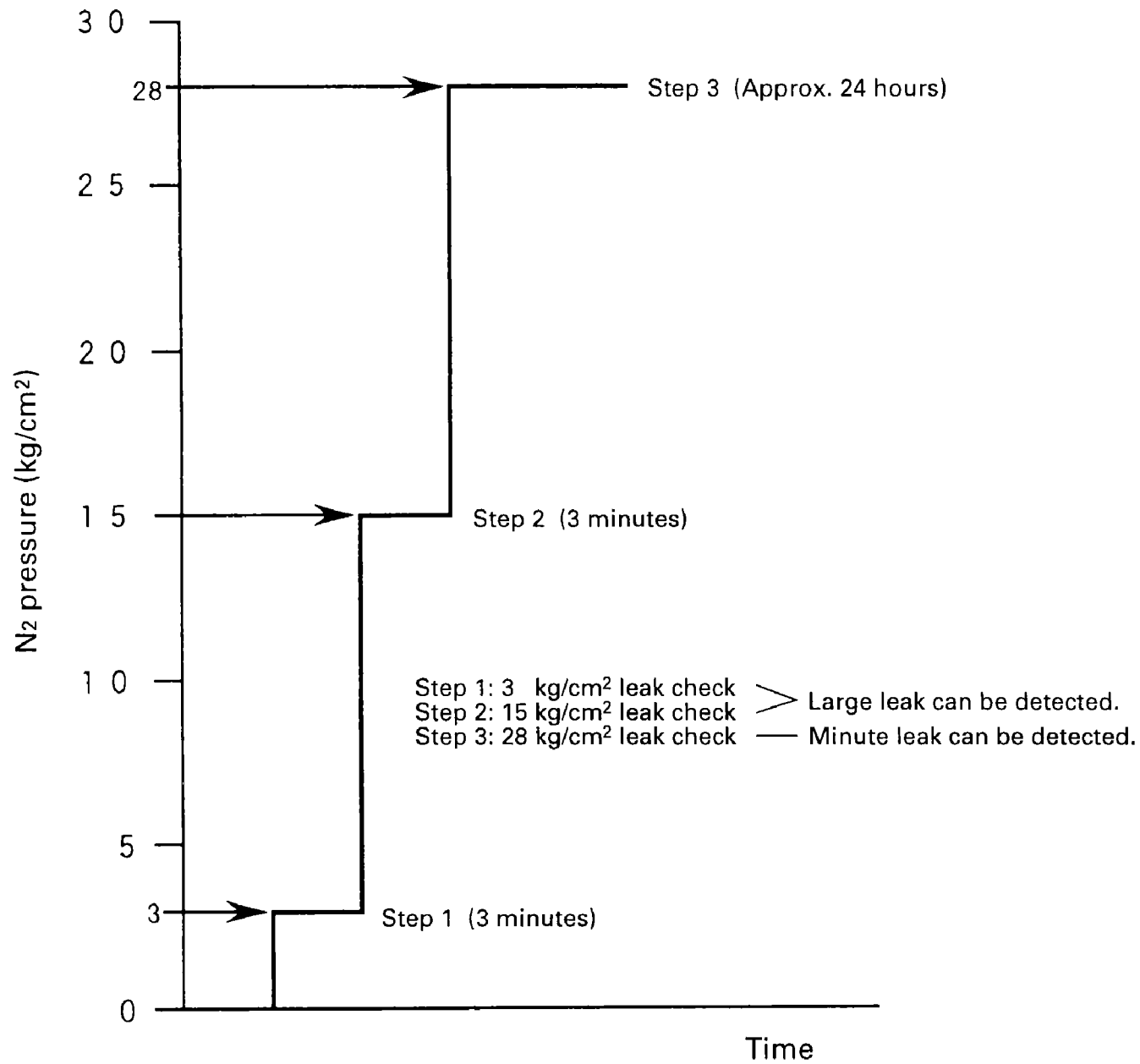

### Leak check method

1. Spray type gas leak detection liquid
  2. Soapwater
  3. Leak tester
  4. Ultrasonic wave detector
- Use one of the above to check for leaking.

### Work points

Be sure to pressurize in 3 stages.

# 11. Vacuum Drying

If vacuum drying is not properly carried out, system malfunction could be caused by air or moisture remaining in the system.

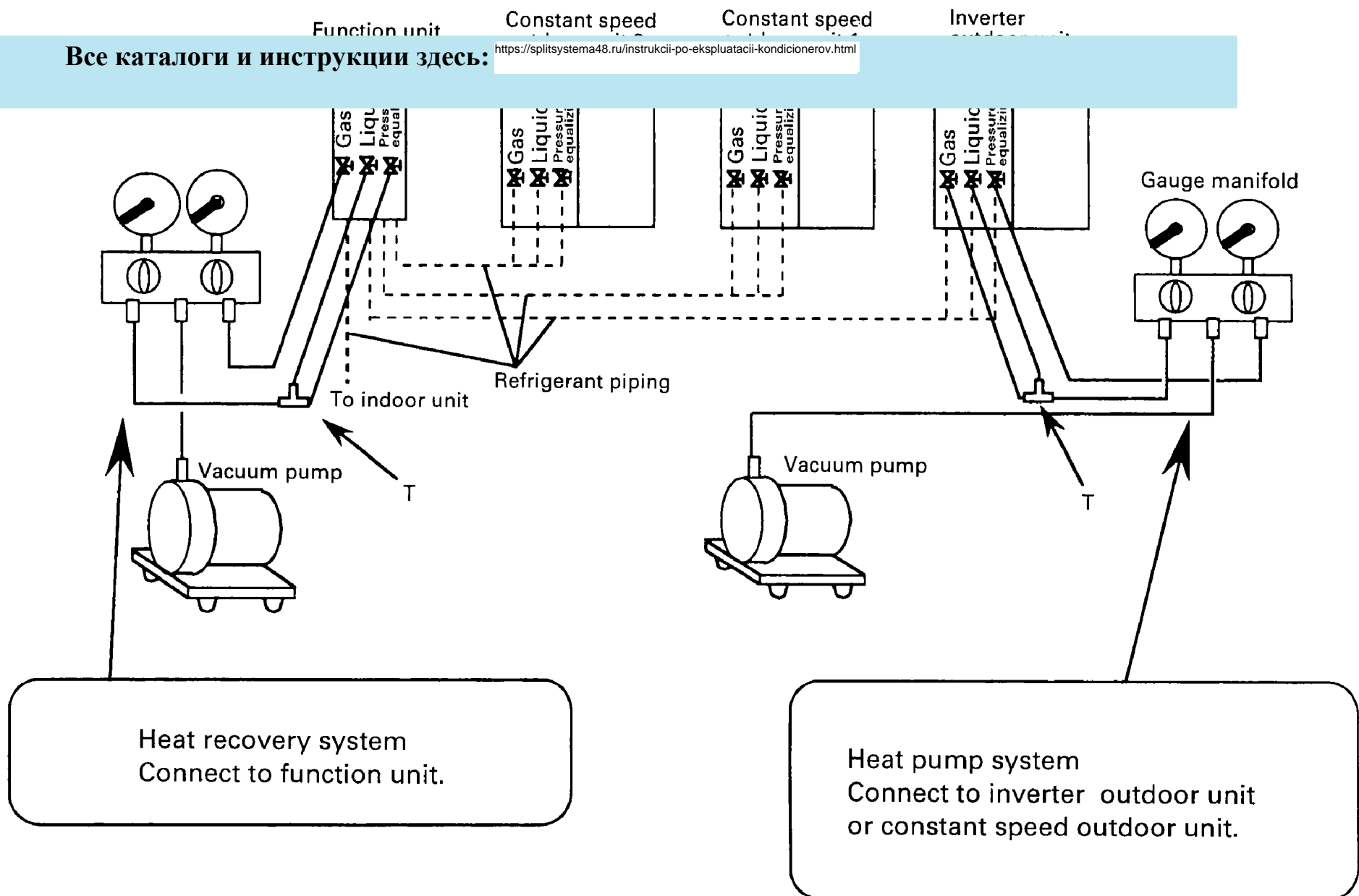

## Work points

1. Use a vacuum pump with sufficient vacuum achievement.
2. Select a pump with comparatively large exhaust output. (60 ~ 100 ℓ /min)
3. Vacuum achievement should not exceed 5 Torr (667 Pa).
4. You may connect any outdoor unit top the gauge manifold, but hoses must be connected in 3 places. (Some sections do not become a vacuum if you vacuum from 2 places.)
5. If using a Heat-recovery system, connect to the service port of the R unit.



## Vacuum Drying

Vacuum drying is a method of drying the inside of piping by changing moisture (liquid) inside the piping into steam (gas) and expelling with a vacuum pump.

The boiling point of water (steam temperature) at 1 atmosphere (760 mmHg) is 100°C. The boiling point becomes lower as the pressure in the piping is lowered. The boiling point becomes lower when the

Все каталоги и инструкции здесь: <https://splitsystema48.ru/instrukcii-po-ekspluatacii-kondicionerov.html>

### [Example]

According to the table on the right, if outdoor temperature is 7.2°C, the degree of vacuum must be 75.2 cmHg or lower.



Boiling point of water (°C)	Pressure		
	※ cmHg	Pa	Torr
40	70.5	7333	55
30	72.4	4800	36
26.7	73.5	3333	25
24.4	73.8	3066	22
22.2	74.0	2666	20
20.6	74.2	2400	18
17.8	74.5	2000	15
15.0	74.7	1733	13
11.7	75.0	1333	10
7.2	75.2	1067	8
0	75.5	667	5

※ The figures given in the cmHg column are the gauge reading.

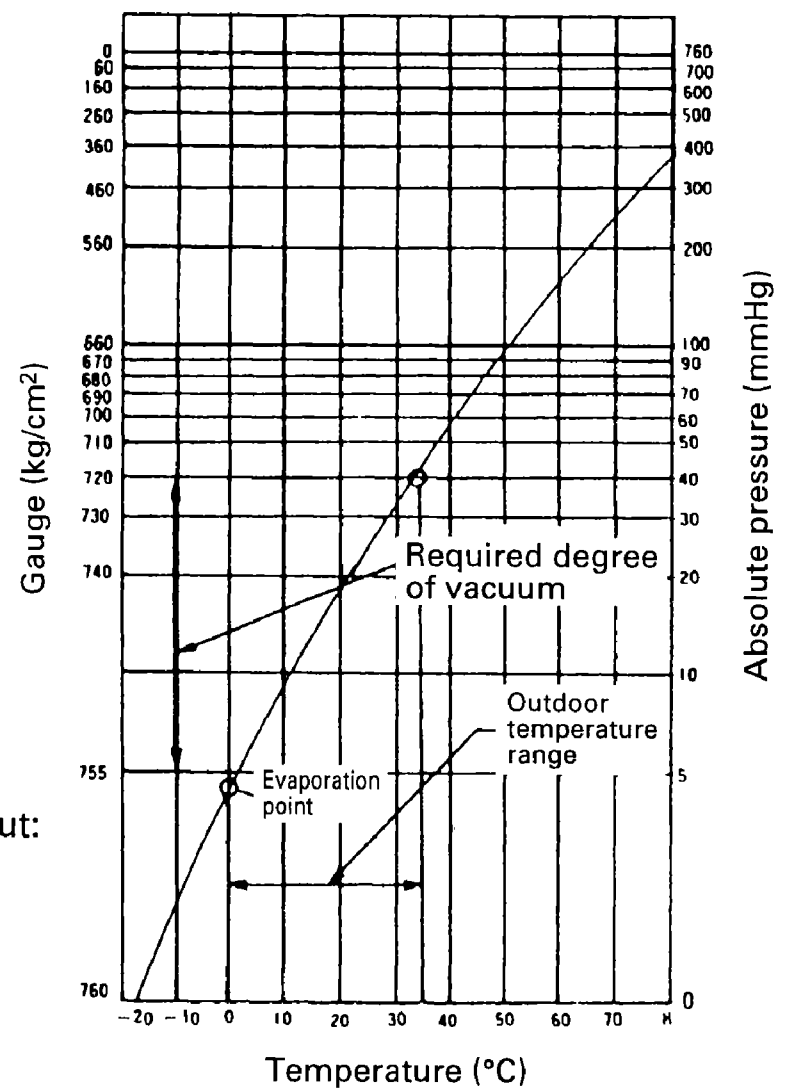

Vacuums requires that both of the following tasks be properly carried out:

1. Vacuum drying (moisture removal)
2. Objective is to discharge air from piping and nitrogen for airtight test.

### Work points

Vacuums must be carried out until 75.5 cmHg (667 Pa, 5 Torr) or less.

## 12. Additional Charge of Refrigerant

### NOTE

1. Refrigerant must be replenished for the VRV PLUS Series just as with past VRV Series.
2. If refrigerant is not replenished, the system will not operate properly.
3. For information on how to calculate the amount of refrigerant to be added, see the installation manual.

### Heat pump system example

Все каталоги и инструкции здесь: <https://splitsystema48.ru/instrukcii-po-ekspluatacii-kondicionerov.html>

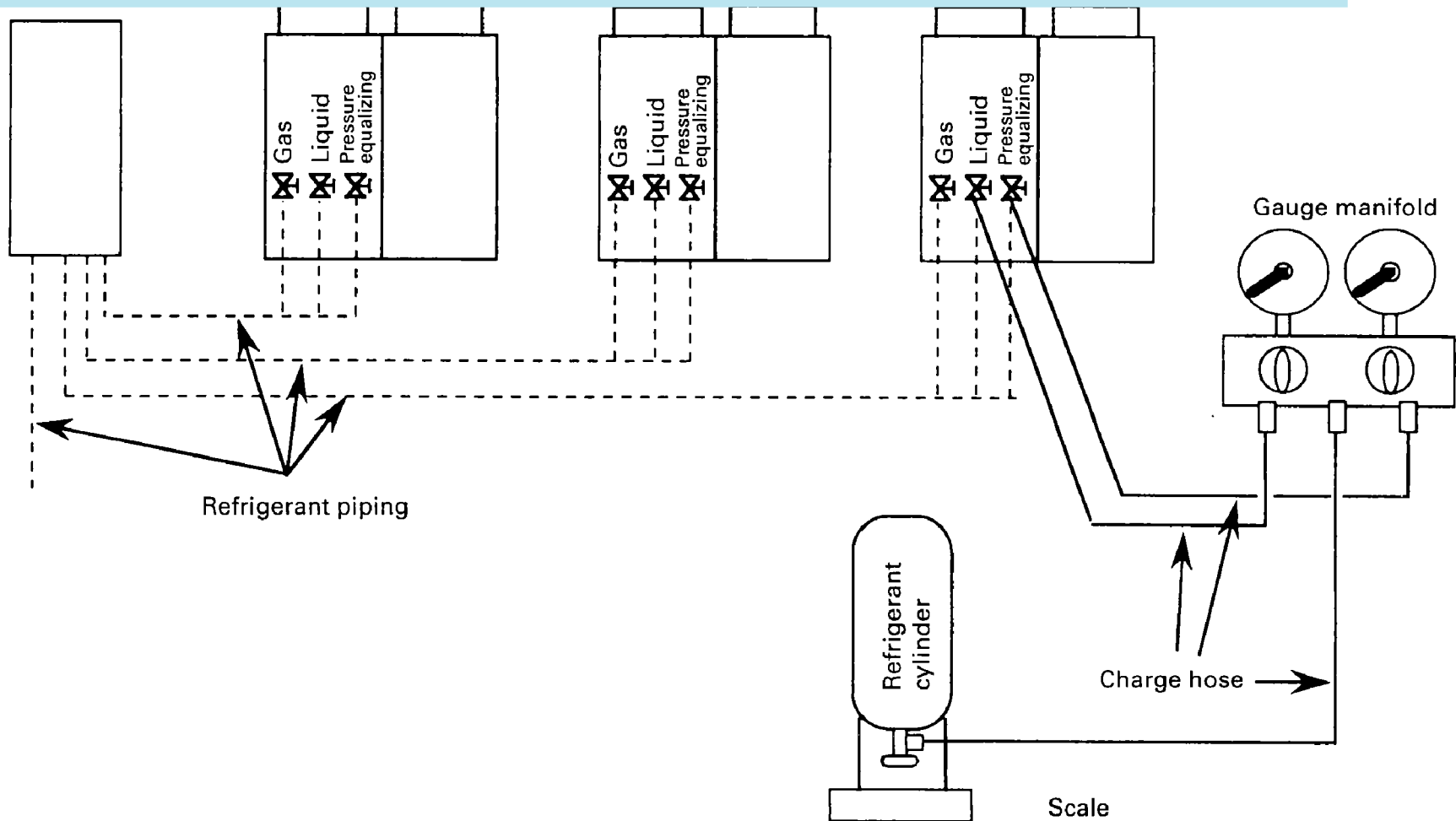

**For Heat-recovery systems, replenish refrigerant from the function unit.**

### Work points

1. Select a level spot to place the scale.
2. Invert the refrigerant cylinder and refill in liquid state.
3. Be careful not to get frostbitten by refrigerant when purging air from the charge hose.  
(About  $-40^{\circ}\text{C}$  in atmosphere for R22)
4. Refill from liquid pipe and pressure equalizing pipe simultaneously.
5. You don't have to replenish refrigerant for each unit.
6. Be sure to record the amount of refrigerant added on the label provided on the outdoor unit for that purpose as a reference for service or maintenance later on.
7. If refilling using a charging cylinder, be sure to read the charging cylinder's instructions before starting.

You must add refrigerant according to the length of piping in the field just as with previous VRV Series. It may be convenient to record the length of the piping after installation on the outdoor unit's label. When you are finished vacuuming the system, add refrigerant before opening the outdoor unit's stop valve. Amount of refrigerant is calculated according to the length of the liquid pipe.

Все каталоги и инструкции здесь: <https://splitsystema48.ru/instrukcii-po-ekspluatacii-kondicionerov.html>

22.2	0.36
19.1	0.27
15.9	0.17
12.7	0.1
9.5	0.05
6.4	0.025

For information concerning addition and replenishment of refrigerant, see the page about "Refrigerant Addition / Replenishment."

### Calculation of additional refrigerant

If function unit is BL2K (E) or BC2K (E)

$$\text{Amount of additional refrigerant (kg)} = \frac{\text{Total length of liquid pipe } \phi 19.1 \times 0.27}{(m) \times 0.27} + \frac{\text{Total length of liquid pipe } \phi 15.9 \times 0.17}{(m) \times 0.17} + \frac{\text{Total length of liquid pipe } \phi 12.7 \times 0.1}{(m) \times 0.1} + \frac{\text{Total length of liquid pipe } \phi 9.5 \times 0.05}{(m) \times 0.05} + \frac{\text{Total length of liquid pipe } \phi 6.4 \times 0.025}{(m) \times 0.025} + 2$$

If function unit is BL3K (E) or BC3K (E)

$$\text{Amount of additional refrigerant (kg)} = \frac{\text{Total length of liquid pipe } \phi 22.2 \times 0.36}{(m) \times 0.36} + \frac{\text{Total length of liquid pipe } \phi 19.1 \times 0.27}{(m) \times 0.27} + \frac{\text{Total length of liquid pipe } \phi 15.9 \times 0.17}{(m) \times 0.17} + \frac{\text{Total length of liquid pipe } \phi 12.7 \times 0.1}{(m) \times 0.1} + \frac{\text{Total length of liquid pipe } \phi 9.5 \times 0.05}{(m) \times 0.05} + \frac{\text{Total length of liquid pipe } \phi 6.4 \times 0.025}{(m) \times 0.025} + 3$$

If function unit is BR2K (E)

$$\text{Amount of additional refrigerant (kg)} = \frac{\text{Total length of liquid pipe } \phi 19.1 \times 0.27}{(m) \times 0.27} + \frac{\text{Total length of liquid pipe } \phi 15.9 \times 0.17}{(m) \times 0.17} + \frac{\text{Total length of liquid pipe } \phi 12.7 \times 0.1}{(m) \times 0.1} + \frac{\text{Total length of liquid pipe } \phi 9.5 \times 0.05}{(m) \times 0.05} + \frac{\text{Total length of liquid pipe } \phi 6.4 \times 0.025}{(m) \times 0.025} + 6$$

If function unit is BR3K (E)

$$\text{Amount of additional refrigerant (kg)} = \frac{\text{Total length of liquid pipe } \phi 22.2 \times 0.36}{(m) \times 0.36} + \frac{\text{Total length of liquid pipe } \phi 19.1 \times 0.27}{(m) \times 0.27} + \frac{\text{Total length of liquid pipe } \phi 15.9 \times 0.17}{(m) \times 0.17} + \frac{\text{Total length of liquid pipe } \phi 12.7 \times 0.1}{(m) \times 0.1} + \frac{\text{Total length of liquid pipe } \phi 9.5 \times 0.05}{(m) \times 0.05} + \frac{\text{Total length of liquid pipe } \phi 6.4 \times 0.025}{(m) \times 0.025} + 8$$

### Work points

When you finish calculating amount of refrigerant to be added, be sure to record the amount on the label.

**Все каталоги и инструкции здесь:** <https://splitsystema48.ru/instrukcii-po-ekspluatacii-kondicionerov.html>

(1) Heat pump system and Cooling only system (RX(Y))

Heat pump system		Branch using REFNET joint ①		Branch using REFNET joint and REFNET header ②		Branch using REFNET header ③																																																																
<p><b>EXAMPLE OF CONNECTION</b> (When 8 indoor units are connected)</p>																																																																						
Maximum allowable length	Between function and outdoor units	Actual pipe length	Pipe length between function and outdoor units 10m or less																																																																			
		Equivalent length	Equivalent pipe length between function and indoor units 12.5m or less																																																																			
Maximum allowable length	Between outdoor and indoor units	Actual pipe length	Pipe length between outdoor and indoor units 100m or less																																																																			
		Equivalent length	(Example) ⑧: $a + d + e + f + g + h + i + j + t \leq 100\text{m}$ (Example) ⑥: $a + d + e + k \leq 100\text{m}$ , ⑧: $a + d + m + p \leq 100\text{m}$ (Example) ⑧: $a + d + m \leq 100\text{m}$																																																																			
Allowable height length	Between adjacent outdoor units	Difference in height	Difference in height between adjacent outdoor units 4m or less																																																																			
	Between function and outdoor units	Difference in height	Difference in height between function and outdoor units 4m or less																																																																			
	Between outdoor and indoor units	Difference in height	Difference in height between outdoor and indoor units (H1) 50m or less (40m or less when outdoor unit is located in a lower position)																																																																			
	Between adjacent indoor units	Difference in height	Difference in height between adjacent indoor units (H2) 15m or less																																																																			
Allowable length after the branch	Actual pipe length		Pipe length from first refrigerant branch kit (either REFNET joint or REFNET header) to indoor unit 40m or less																																																																			
			(Example) ⑧: $e + f + g + h + i + j + t \leq 40\text{m}$ (Example) ⑥: $e + k \leq 40\text{m}$ , ⑦: $m + p \leq 40\text{m}$ (Example) ⑧: $m \leq 40\text{m}$																																																																			
Refrigerant branch kit selection			<p><b>How to select REFNET joint</b></p> <ul style="list-style-type: none"> <li>When using REFNET joints on the first branch counted from the function unit side. If system capacity is less than 500, use KHRJ26K40T+KHRJ26K40TP. If system capacity is 500 or greater, use KHRJ26K75T+KHRJ26K75TP.</li> <li>In the case of REFNET joints other than the first branch, select the proper branch kit model based on the total capacity sum (for computation) of the indoor units installed after the first branch using the following table. (For the total capacity, see the item 1 in the section under "COMBINATION" at the beginning.)</li> </ul> <table border="1"> <tr><td>Less than 100</td><td>KHRJ26K11T</td></tr> <tr><td>100 or more to 160 (160 excluded)</td><td>KHRJ26K18T</td></tr> <tr><td>160 or more to 330 (330 excluded)</td><td>KHRJ26K37T</td></tr> <tr><td>330 or more to 640 (640 excluded)</td><td>KHRJ26K40T + KHRJ26K40TP (Pipe Size Reducer)</td></tr> <tr><td>640 or more</td><td>KHRJ26K75T + KHRJ26K75TP (Pipe Size Reducer)</td></tr> </table>		Less than 100	KHRJ26K11T	100 or more to 160 (160 excluded)	KHRJ26K18T	160 or more to 330 (330 excluded)	KHRJ26K37T	330 or more to 640 (640 excluded)	KHRJ26K40T + KHRJ26K40TP (Pipe Size Reducer)	640 or more	KHRJ26K75T + KHRJ26K75TP (Pipe Size Reducer)	<p><b>How to select REFNET header</b></p> <ul style="list-style-type: none"> <li>Select the proper branch kit model based on the total capacity sum (for computation) of the indoor units installed after the header using the following table. (For the total capacity, see the item 1 in the section under "COMBINATION" at the beginning.)</li> <li>Branching is impossible between REFNET header and indoor unit.</li> </ul> <table border="1"> <tr><td>Less than 100</td><td>KHRJ26K11H (Max. 4 branches)</td></tr> <tr><td>100 or more to 160 (160 excluded)</td><td>KHRJ26K18H (Max. 6 branches)</td></tr> <tr><td>160 or more to 330 (330 excluded)</td><td>KHRJ26K37H (Max. 8 branches)</td></tr> <tr><td>330 or more to 640 (640 excluded)</td><td>KHRJ26K40H (Max. 8 branches) + KHRJ26K40HP (Pipe Size Reducer)</td></tr> </table> <p>For systems with a total capacity of 640 and over, connect a REFNET header after the REFNET joint branch.</p>			Less than 100	KHRJ26K11H (Max. 4 branches)	100 or more to 160 (160 excluded)	KHRJ26K18H (Max. 6 branches)	160 or more to 330 (330 excluded)	KHRJ26K37H (Max. 8 branches)	330 or more to 640 (640 excluded)	KHRJ26K40H (Max. 8 branches) + KHRJ26K40HP (Pipe Size Reducer)																																													
Less than 100	KHRJ26K11T																																																																					
100 or more to 160 (160 excluded)	KHRJ26K18T																																																																					
160 or more to 330 (330 excluded)	KHRJ26K37T																																																																					
330 or more to 640 (640 excluded)	KHRJ26K40T + KHRJ26K40TP (Pipe Size Reducer)																																																																					
640 or more	KHRJ26K75T + KHRJ26K75TP (Pipe Size Reducer)																																																																					
Less than 100	KHRJ26K11H (Max. 4 branches)																																																																					
100 or more to 160 (160 excluded)	KHRJ26K18H (Max. 6 branches)																																																																					
160 or more to 330 (330 excluded)	KHRJ26K37H (Max. 8 branches)																																																																					
330 or more to 640 (640 excluded)	KHRJ26K40H (Max. 8 branches) + KHRJ26K40HP (Pipe Size Reducer)																																																																					
Example of downstream indoor units			(Example) In case of REFNET joint C Indoor units ③ + ④ + ⑤ + ⑥ + ⑦ + ⑧.		(Example) In the case of REFNET joint B Indoor units ⑦ + ⑧. (Example) In the case of REFNET header Indoor units ① + ② + ③ + ④ + ⑤ + ⑥.		(Example) In the case of REFNET header Indoor units ① + ② + ③ + ④ + ⑤ + ⑥ + ⑦ + ⑧.																																																															
Outline of selecting pipe size			<p><b>Between function unit and outdoor unit</b></p> <ul style="list-style-type: none"> <li>Match the pipe size to that connected to outdoor unit.</li> </ul> <table border="1"> <caption>Pipe size connected to outdoor unit. (Unit: mm)</caption> <thead> <tr> <th rowspan="2">Outdoor system name</th> <th colspan="3">Pipe size (Outer diameter x minimum wall thickness)</th> </tr> <tr> <th>Liquid pipe</th> <th>Gas pipe</th> <th>Equalizing pipe</th> </tr> </thead> <tbody> <tr><td>RX(Y)8K(E)</td><td>φ12.7 x 10.8</td><td>φ25.4 x 11.2</td><td>φ19.1 x 11.0</td></tr> <tr><td>RX(Y)10K(E)</td><td>φ12.7 x 10.8</td><td>φ28.6 x 11.2</td><td>φ19.1 x 11.0</td></tr> <tr><td>RN(Y)8K(E)</td><td>φ12.7 x 10.8</td><td>φ25.4 x 11.2</td><td>φ19.1 x 11.0</td></tr> <tr><td>RN(Y)10K(E)</td><td>φ12.7 x 10.8</td><td>φ28.6 x 11.2</td><td>φ19.1 x 11.0</td></tr> </tbody> </table>		Outdoor system name	Pipe size (Outer diameter x minimum wall thickness)			Liquid pipe	Gas pipe	Equalizing pipe	RX(Y)8K(E)	φ12.7 x 10.8	φ25.4 x 11.2	φ19.1 x 11.0	RX(Y)10K(E)	φ12.7 x 10.8	φ28.6 x 11.2	φ19.1 x 11.0	RN(Y)8K(E)	φ12.7 x 10.8	φ25.4 x 11.2	φ19.1 x 11.0	RN(Y)10K(E)	φ12.7 x 10.8	φ28.6 x 11.2	φ19.1 x 11.0	<p><b>Between function unit and uppermost stream refrigerant branch kit</b></p> <ul style="list-style-type: none"> <li>Select pipe size according to outdoor system name.</li> </ul> <table border="1"> <caption>Pipe size connected to outdoor unit. (Unit: mm)</caption> <thead> <tr> <th rowspan="2">Outdoor system name</th> <th colspan="2">Pipe size (Outer diameter x minimum wall thickness)</th> </tr> <tr> <th>Liquid pipe</th> <th>Gas pipe</th> </tr> </thead> <tbody> <tr><td>RX(Y)16K</td><td>φ15.9 x 11.0</td><td>φ34.9 x 11.3</td></tr> <tr><td>RX(Y)18~20K</td><td>φ19.1 x 11.0</td><td>φ34.9 x 11.3</td></tr> <tr><td>RX(Y)24K</td><td>φ19.1 x 11.0</td><td>φ41.3 x 11.7</td></tr> <tr><td>RX(Y)26~30K</td><td>φ22.2 x 11.2</td><td>φ41.3 x 11.7</td></tr> </tbody> </table>		Outdoor system name	Pipe size (Outer diameter x minimum wall thickness)		Liquid pipe	Gas pipe	RX(Y)16K	φ15.9 x 11.0	φ34.9 x 11.3	RX(Y)18~20K	φ19.1 x 11.0	φ34.9 x 11.3	RX(Y)24K	φ19.1 x 11.0	φ41.3 x 11.7	RX(Y)26~30K	φ22.2 x 11.2	φ41.3 x 11.7	<p><b>Between two immediately adjacent refrigerant branch kit</b></p> <ul style="list-style-type: none"> <li>Select the proper pipe size based on the total capacity sum (for computation) of the indoor units connected downstream using the following table. (For the total capacity see the item in the selection under "COMBINATION" at the beginning.)</li> <li>Select connection pipe size according to outdoor unit (table on left). Do not select a larger size pipe.</li> </ul> <table border="1"> <caption>Connection pipe size of indoor unit (Unit: mm)</caption> <thead> <tr> <th rowspan="2">Indoor unit capacity sum of indoor units</th> <th colspan="2">Pipe size (Outer diameter x minimum wall thickness)</th> </tr> <tr> <th>Gas pipe</th> <th>Liquid pipe</th> </tr> </thead> <tbody> <tr><td>20 · 25 · 32 · 40</td><td>φ12.7 x 0.8</td><td>φ6.4 x 0.8</td></tr> <tr><td>50 · 63 · 80</td><td>φ15.9 x 1.0</td><td>φ9.5 x 0.8</td></tr> <tr><td>100 · 125</td><td>φ19.1 x 1.0</td><td></td></tr> <tr><td>200</td><td>φ25.4 x 1.2</td><td>φ12.7 x 0.8</td></tr> <tr><td>250</td><td>φ28.6 x 1.2</td><td>φ12.7 x 0.8</td></tr> </tbody> </table>		Indoor unit capacity sum of indoor units	Pipe size (Outer diameter x minimum wall thickness)		Gas pipe	Liquid pipe	20 · 25 · 32 · 40	φ12.7 x 0.8	φ6.4 x 0.8	50 · 63 · 80	φ15.9 x 1.0	φ9.5 x 0.8	100 · 125	φ19.1 x 1.0		200	φ25.4 x 1.2	φ12.7 x 0.8	250	φ28.6 x 1.2	φ12.7 x 0.8	<p><b>Between refrigerant branch kit and indoor unit</b></p> <ul style="list-style-type: none"> <li>Pipe size direct connection to indoor unit must be the same as the connection size of indoor unit.</li> </ul>	
Outdoor system name	Pipe size (Outer diameter x minimum wall thickness)																																																																					
	Liquid pipe	Gas pipe	Equalizing pipe																																																																			
RX(Y)8K(E)	φ12.7 x 10.8	φ25.4 x 11.2	φ19.1 x 11.0																																																																			
RX(Y)10K(E)	φ12.7 x 10.8	φ28.6 x 11.2	φ19.1 x 11.0																																																																			
RN(Y)8K(E)	φ12.7 x 10.8	φ25.4 x 11.2	φ19.1 x 11.0																																																																			
RN(Y)10K(E)	φ12.7 x 10.8	φ28.6 x 11.2	φ19.1 x 11.0																																																																			
Outdoor system name	Pipe size (Outer diameter x minimum wall thickness)																																																																					
	Liquid pipe	Gas pipe																																																																				
RX(Y)16K	φ15.9 x 11.0	φ34.9 x 11.3																																																																				
RX(Y)18~20K	φ19.1 x 11.0	φ34.9 x 11.3																																																																				
RX(Y)24K	φ19.1 x 11.0	φ41.3 x 11.7																																																																				
RX(Y)26~30K	φ22.2 x 11.2	φ41.3 x 11.7																																																																				
Indoor unit capacity sum of indoor units	Pipe size (Outer diameter x minimum wall thickness)																																																																					
	Gas pipe	Liquid pipe																																																																				
20 · 25 · 32 · 40	φ12.7 x 0.8	φ6.4 x 0.8																																																																				
50 · 63 · 80	φ15.9 x 1.0	φ9.5 x 0.8																																																																				
100 · 125	φ19.1 x 1.0																																																																					
200	φ25.4 x 1.2	φ12.7 x 0.8																																																																				
250	φ28.6 x 1.2	φ12.7 x 0.8																																																																				
Outline of how to computer quantity of refrigerant to be charged additionally.			<p>When using BL2K (E) BC2K(E) function unit</p> $\text{Quantity of additional charge (kg)} = \left( \frac{\text{Total length of 19.1mm dia. liquid line}}{(m) \times 0.27} \right) + \left( \frac{\text{Total length of 15.9mm dia. liquid line}}{(m) \times 0.17} \right) + \left( \frac{\text{Total length of 12.7mm dia. liquid line}}{(m) \times 0.1} \right) + \left( \frac{\text{Total length of 9.5mm dia. liquid line}}{(m) \times 0.05} \right) + \left( \frac{\text{Total length of 6.4mm dia. liquid line}}{(m) \times 0.025} \right) + 2$		<p>When using BL3K (E) BC3K(E) function unit</p> $\text{Quantity of additional charge (kg)} = \left( \frac{\text{Total length of 22.2mm dia. liquid line}}{(m) \times 0.36} \right) + \left( \frac{\text{Total length of 19.1mm dia. liquid line}}{(m) \times 0.27} \right) + \left( \frac{\text{Total length of 15.9mm dia. liquid line}}{(m) \times 0.17} \right) + \left( \frac{\text{Total length of 12.7mm dia. liquid line}}{(m) \times 0.1} \right) + \left( \frac{\text{Total length of 9.5mm dia. liquid line}}{(m) \times 0.05} \right) + \left( \frac{\text{Total length of 6.4mm dia. liquid line}}{(m) \times 0.025} \right) + 3$ <p style="text-align: center;">* Addition refrigerant charge: 0.1 kg (Round off to nearest 1/10th)</p>																																																																	
<p>(Example) For refrigerant branch ② using REFNET joint and REFNET header</p> <table border="1"> <tr><td>a : φ12.7 x 10m</td><td>d : φ22.2 x 30m</td><td>g : φ 6.4 x 10m</td><td>j : φ 9.5 x 10m</td><td>n : φ12.7 x 10m</td></tr> <tr><td>b : φ12.7 x 7m</td><td>e : φ15.9 x 10m</td><td>h : φ 9.5 x 10m</td><td>k : φ 9.5 x 20m</td><td>p : φ12.7 x 9m</td></tr> <tr><td>c : φ12.7 x 4m</td><td>f : φ 6.4 x 9m</td><td>i : φ 9.5 x 10m</td><td>m : φ15.9 x 10m</td><td></td></tr> </table> $[30 \times 0.36] + [20 \times 0.17] + [40 \times 0.1] + [50 \times 0.05] + [19 \times 0.025] + 3 = 24.175$ <table border="1"> <tr><td>d</td><td>e+m</td><td>a+b+c+n+p</td><td>h+i+j+k</td><td>f+g</td></tr> <tr><td>↑</td><td>↑</td><td>↑</td><td>↑</td><td>↑</td></tr> <tr><td></td><td></td><td></td><td></td><td>24.2 kg</td></tr> </table>								a : φ12.7 x 10m	d : φ22.2 x 30m	g : φ 6.4 x 10m	j : φ 9.5 x 10m	n : φ12.7 x 10m	b : φ12.7 x 7m	e : φ15.9 x 10m	h : φ 9.5 x 10m	k : φ 9.5 x 20m	p : φ12.7 x 9m	c : φ12.7 x 4m	f : φ 6.4 x 9m	i : φ 9.5 x 10m	m : φ15.9 x 10m		d	e+m	a+b+c+n+p	h+i+j+k	f+g	↑	↑	↑	↑	↑					24.2 kg																																	
a : φ12.7 x 10m	d : φ22.2 x 30m	g : φ 6.4 x 10m	j : φ 9.5 x 10m	n : φ12.7 x 10m																																																																		
b : φ12.7 x 7m	e : φ15.9 x 10m	h : φ 9.5 x 10m	k : φ 9.5 x 20m	p : φ12.7 x 9m																																																																		
c : φ12.7 x 4m	f : φ 6.4 x 9m	i : φ 9.5 x 10m	m : φ15.9 x 10m																																																																			
d	e+m	a+b+c+n+p	h+i+j+k	f+g																																																																		
↑	↑	↑	↑	↑																																																																		
				24.2 kg																																																																		

## (2) Heat recovery System (REY)

Heat recovery system		Branch using REFNET joint ①		Branch using REFNET joint and REFNET header ②		Branch using REFNET header ③																																																																																																		
<p><b>EXAMPLE OF CONNECTION</b> (When 8 indoor units are connected)</p>																																																																																																								
Maximum allowable length	Between function and outdoor units	Actual pipe length	Pipe length between function and outdoor units 10m or less																																																																																																					
		Equivalent length	Equivalent pipe length between function and indoor units 12.5m or less																																																																																																					
	Between outdoor and indoor units	Actual pipe length	Pipe length between outdoor and indoor units 100m or less																																																																																																					
		Equivalent length	Equivalent pipe length between outdoor and indoor units 125m or less (Assume equivalent pipe length of function unit to be 5m, that of function unit to be 0.5m, that of REFNET header to be 1m, computation purposes)																																																																																																					
Allowable height length	Between adjacent outdoor units	Difference in height	Difference in height between adjacent outdoor units 4m or less																																																																																																					
	Between function and outdoor units	Difference in height	Difference in height between function and outdoor units 4m or less																																																																																																					
	Between outdoor and indoor units	Difference in height	Difference in height between outdoor and indoor units (H1) 50m or less (40m or less when outdoor unit is located in a lower position)																																																																																																					
	Between adjacent indoor units	Difference in height	Difference in height between adjacent indoor units (H2) 15m or less																																																																																																					
Allowable length after the branch	Actual pipe length	Pipe length from first refrigerant branch kit (either REFNET joint or REFNET header) to indoor unit 40m or less																																																																																																						
		(Example) ⑧: e + f + g + h + w ≤ 40m		(Example) ⑥: i + t ≤ 40m, ⑧: e + f + h ≤ 40m		(Example) ⑧: m ≤ 40m																																																																																																		
Refrigerant branch kit selection		<p><b>How to select REFNET joint</b></p> <ul style="list-style-type: none"> <li>When using REFNET joints on the first branch counted from the function unit side. If system capacity is less than 500, use KHRJ25K40T + KHRJ26K40TP. If system capacity is 500 or greater, use KHRJ25K75T + KHRJ25K75TP.</li> <li>In the case of REFNET joints other than the first branch, select the proper branch kit model based on the total capacity sum (for computation) of the indoor units installed after the first branch using the following table. (For the total capacity, see the item 1 in the section under "COMBINATION" at the beginning.)</li> </ul> <table border="1"> <tr> <td>Less than 160</td> <td>KHRJ25K18T</td> </tr> <tr> <td>160 or more to 330 (330 excluded)</td> <td>KHRJ25K37T</td> </tr> <tr> <td>330 or more to 640 (640 excluded)</td> <td>KHRJ25K40T + KHRJ26K40TP (Pipe Size Reducer)</td> </tr> <tr> <td>640 or more</td> <td>KHRJ25K75T + KHRJ25K75TP (Pipe Size Reducer)</td> </tr> </table>		Less than 160	KHRJ25K18T	160 or more to 330 (330 excluded)	KHRJ25K37T	330 or more to 640 (640 excluded)	KHRJ25K40T + KHRJ26K40TP (Pipe Size Reducer)	640 or more	KHRJ25K75T + KHRJ25K75TP (Pipe Size Reducer)	<p><b>How to select REFNET header</b></p> <ul style="list-style-type: none"> <li>Select the proper branch kit model based on the total capacity sum (for computation) of the indoor units after the header using the following table. (For the total capacity, see the item 1 in the section under "COMBINATION" at the beginning.)</li> <li>Branching is impossible between REFNET header and indoor unit.</li> </ul> <table border="1"> <tr> <td>Less than 160</td> <td>KHRJ25K18H (Max. 6 branches)</td> </tr> <tr> <td>160 or more to 330 (330 excluded)</td> <td>KHRJ25K38H (Max. 8 branches)</td> </tr> <tr> <td>330 or more to 640 (640 excluded)</td> <td>KHRJ25K40H (Max. 8 branches) + KHRJ26K40HP (Pipe Size Reducer)</td> </tr> </table> <p>For systems with a total capacity of 640 and over, connect a REFNET header after the REFNET joint.</p>		Less than 160	KHRJ25K18H (Max. 6 branches)	160 or more to 330 (330 excluded)	KHRJ25K38H (Max. 8 branches)	330 or more to 640 (640 excluded)	KHRJ25K40H (Max. 8 branches) + KHRJ26K40HP (Pipe Size Reducer)																																																																																					
Less than 160	KHRJ25K18T																																																																																																							
160 or more to 330 (330 excluded)	KHRJ25K37T																																																																																																							
330 or more to 640 (640 excluded)	KHRJ25K40T + KHRJ26K40TP (Pipe Size Reducer)																																																																																																							
640 or more	KHRJ25K75T + KHRJ25K75TP (Pipe Size Reducer)																																																																																																							
Less than 160	KHRJ25K18H (Max. 6 branches)																																																																																																							
160 or more to 330 (330 excluded)	KHRJ25K38H (Max. 8 branches)																																																																																																							
330 or more to 640 (640 excluded)	KHRJ25K40H (Max. 8 branches) + KHRJ26K40HP (Pipe Size Reducer)																																																																																																							
Example of downstream indoor units		(Example) In case of REFNET joint C Indoor units ⑤ + ⑥ + ⑦ + ⑧		(Example) In case of REFNET joint B Indoor units ⑦ + ⑧. (Example) In the case of REFNET header Indoor units ① + ② + ③ + ④ + ⑤ + ⑥.		(Example) In the case of REFNET header Indoor units ① + ② + ③ + ④ + ⑤ + ⑥ + ⑦ + ⑧																																																																																																		
Outline of selecting pipe size		<p><b>Between function unit and outdoor unit</b></p> <ul style="list-style-type: none"> <li>Match the pipe size to that connected to outdoor unit.</li> </ul> <p>Pipe size connected to outdoor unit. (Unit: mm)</p> <table border="1"> <thead> <tr> <th>Outdoor system name</th> <th>Liquid pipe</th> <th>Gas pipe</th> <th>Equalizing pipe</th> </tr> </thead> <tbody> <tr> <td>RXY8K(E)</td> <td>φ12.7 x 10.8</td> <td>φ25.4 x 11.2</td> <td>φ19.1 x 11.0</td> </tr> <tr> <td>RXY10K(E)</td> <td>φ12.7 x 10.8</td> <td>φ28.6 x 11.2</td> <td>φ19.1 x 11.0</td> </tr> <tr> <td>RNY8K(E)</td> <td>φ12.7 x 10.8</td> <td>φ25.4 x 11.2</td> <td>φ19.1 x 11.0</td> </tr> <tr> <td>RNY10K(E)</td> <td>φ12.7 x 10.8</td> <td>φ28.6 x 11.2</td> <td>φ19.1 x 11.0</td> </tr> </tbody> </table>		Outdoor system name	Liquid pipe	Gas pipe	Equalizing pipe	RXY8K(E)	φ12.7 x 10.8	φ25.4 x 11.2	φ19.1 x 11.0	RXY10K(E)	φ12.7 x 10.8	φ28.6 x 11.2	φ19.1 x 11.0	RNY8K(E)	φ12.7 x 10.8	φ25.4 x 11.2	φ19.1 x 11.0	RNY10K(E)	φ12.7 x 10.8	φ28.6 x 11.2	φ19.1 x 11.0	<p><b>Between function unit and uppermost stream refrigerant branch kit</b></p> <ul style="list-style-type: none"> <li>Select pipe size according to outdoor system.</li> </ul> <p>Pipe size connected to outdoor unit. (Unit: mm)</p> <table border="1"> <thead> <tr> <th>Outdoor system name</th> <th>Liquid pipe</th> <th>Suction gas pipe</th> <th>Discharge Gas pipe</th> </tr> </thead> <tbody> <tr> <td>REY16K</td> <td>φ15.9 x 11.0</td> <td>φ34.9 x 11.3</td> <td>φ25.4 x 11.2</td> </tr> <tr> <td>REY18-20K</td> <td>φ19.1 x 11.0</td> <td>φ34.9 x 11.3</td> <td>φ25.4 x 11.2</td> </tr> <tr> <td>REY24K</td> <td>φ19.1 x 11.0</td> <td>φ41.3 x 11.7</td> <td>φ28.6 x 11.2</td> </tr> <tr> <td>REY26K</td> <td>φ22.2 x 11.2</td> <td>φ41.3 x 11.7</td> <td>φ28.6 x 11.2</td> </tr> <tr> <td>REY28-30K</td> <td>φ22.2 x 11.2</td> <td>φ41.3 x 11.7</td> <td>φ34.9 x 11.3</td> </tr> </tbody> </table>		Outdoor system name	Liquid pipe	Suction gas pipe	Discharge Gas pipe	REY16K	φ15.9 x 11.0	φ34.9 x 11.3	φ25.4 x 11.2	REY18-20K	φ19.1 x 11.0	φ34.9 x 11.3	φ25.4 x 11.2	REY24K	φ19.1 x 11.0	φ41.3 x 11.7	φ28.6 x 11.2	REY26K	φ22.2 x 11.2	φ41.3 x 11.7	φ28.6 x 11.2	REY28-30K	φ22.2 x 11.2	φ41.3 x 11.7	φ34.9 x 11.3	<p><b>Between two immediately adjacent refrigerant branch kit and BS unit</b></p> <ul style="list-style-type: none"> <li>Select the proper pipe size based on the total capacity sum (for computation) of the indoor units connected downstream using the following table. (For the total capacity see the item in the selection under "COMBINATION" at the beginning.)</li> <li>Select connection pipe size according to outdoor unit (table on left). Do not select a larger size pipe.</li> </ul> <p>(Unit: mm)</p> <table border="1"> <thead> <tr> <th rowspan="2">Outdoor system name</th> <th colspan="3">Pipe size (Outer diameter x minimum wall thickness)</th> </tr> <tr> <th>Liquid pipe</th> <th>Suction gas pipe</th> <th>Discharge Gas pipe</th> </tr> </thead> <tbody> <tr> <td>Less than 50</td> <td>φ6.4 x 10.8</td> <td>φ12.7 x 10.8</td> <td>φ9.5 x 10.8</td> </tr> <tr> <td>50 or more to 100 (100 excluded)</td> <td>φ9.5 x 10.8</td> <td>φ15.9 x 11.0</td> <td>φ12.7 x 10.8</td> </tr> <tr> <td>100 or more to 160 (160 excluded)</td> <td>φ9.5 x 10.8</td> <td>φ19.1 x 11.0</td> <td>φ15.9 x 11.0</td> </tr> <tr> <td>160 or more to 330 (330 excluded)</td> <td>φ12.7 x 10.8</td> <td>φ25.4 x 11.2</td> <td>φ19.1 x 11.0</td> </tr> <tr> <td>330 or more to 480 (480 excluded)</td> <td>φ15.9 x 11.0</td> <td>φ34.9 x 11.3</td> <td>φ25.4 x 11.2</td> </tr> <tr> <td>480 or more to 640 (640 excluded)</td> <td>φ19.1 x 11.0</td> <td>φ34.9 x 11.3</td> <td>φ25.4 x 11.2</td> </tr> <tr> <td>640 or more to 700 (700 excluded)</td> <td>φ19.1 x 11.0</td> <td>φ41.3 x 11.7</td> <td>φ25.4 x 11.2</td> </tr> <tr> <td>700 or more</td> <td>φ19.1 x 11.0</td> <td>φ41.3 x 11.7</td> <td>φ34.9 x 11.3</td> </tr> </tbody> </table>		Outdoor system name	Pipe size (Outer diameter x minimum wall thickness)			Liquid pipe	Suction gas pipe	Discharge Gas pipe	Less than 50	φ6.4 x 10.8	φ12.7 x 10.8	φ9.5 x 10.8	50 or more to 100 (100 excluded)	φ9.5 x 10.8	φ15.9 x 11.0	φ12.7 x 10.8	100 or more to 160 (160 excluded)	φ9.5 x 10.8	φ19.1 x 11.0	φ15.9 x 11.0	160 or more to 330 (330 excluded)	φ12.7 x 10.8	φ25.4 x 11.2	φ19.1 x 11.0	330 or more to 480 (480 excluded)	φ15.9 x 11.0	φ34.9 x 11.3	φ25.4 x 11.2	480 or more to 640 (640 excluded)	φ19.1 x 11.0	φ34.9 x 11.3	φ25.4 x 11.2	640 or more to 700 (700 excluded)	φ19.1 x 11.0	φ41.3 x 11.7	φ25.4 x 11.2	700 or more	φ19.1 x 11.0	φ41.3 x 11.7	φ34.9 x 11.3	<p><b>Between BS unit (refrigerant branch kit) and indoor unit</b></p> <ul style="list-style-type: none"> <li>Pipe size direct connection to indoor unit is the same as the connection size of indoor unit.</li> </ul> <p>Connection pipe size of indoor unit</p> <table border="1"> <thead> <tr> <th>Indoor unit capacity sum of indoor units</th> <th>Pipe size (Outer diameter x minimum wall thickness)</th> </tr> </thead> <tbody> <tr> <td>* 20 · 25 · 32 · 40</td> <td>φ12.7 x 0.8</td> </tr> <tr> <td>50 · 63 · 80</td> <td>φ15.9 x 1.0</td> </tr> <tr> <td>100 · 125</td> <td>φ19.1 x 1.0</td> </tr> <tr> <td>200</td> <td>φ25.4 x 1.2</td> </tr> <tr> <td>250</td> <td>φ28.6 x 1.2</td> </tr> </tbody> </table> <p>* mark indicates the BS unit (BSV10) connection pipe are different sizes. Units are included with the BS unit.</p>		Indoor unit capacity sum of indoor units	Pipe size (Outer diameter x minimum wall thickness)	* 20 · 25 · 32 · 40	φ12.7 x 0.8	50 · 63 · 80	φ15.9 x 1.0	100 · 125	φ19.1 x 1.0	200	φ25.4 x 1.2	250	φ28.6 x 1.2
Outdoor system name	Liquid pipe	Gas pipe	Equalizing pipe																																																																																																					
RXY8K(E)	φ12.7 x 10.8	φ25.4 x 11.2	φ19.1 x 11.0																																																																																																					
RXY10K(E)	φ12.7 x 10.8	φ28.6 x 11.2	φ19.1 x 11.0																																																																																																					
RNY8K(E)	φ12.7 x 10.8	φ25.4 x 11.2	φ19.1 x 11.0																																																																																																					
RNY10K(E)	φ12.7 x 10.8	φ28.6 x 11.2	φ19.1 x 11.0																																																																																																					
Outdoor system name	Liquid pipe	Suction gas pipe	Discharge Gas pipe																																																																																																					
REY16K	φ15.9 x 11.0	φ34.9 x 11.3	φ25.4 x 11.2																																																																																																					
REY18-20K	φ19.1 x 11.0	φ34.9 x 11.3	φ25.4 x 11.2																																																																																																					
REY24K	φ19.1 x 11.0	φ41.3 x 11.7	φ28.6 x 11.2																																																																																																					
REY26K	φ22.2 x 11.2	φ41.3 x 11.7	φ28.6 x 11.2																																																																																																					
REY28-30K	φ22.2 x 11.2	φ41.3 x 11.7	φ34.9 x 11.3																																																																																																					
Outdoor system name	Pipe size (Outer diameter x minimum wall thickness)																																																																																																							
	Liquid pipe	Suction gas pipe	Discharge Gas pipe																																																																																																					
Less than 50	φ6.4 x 10.8	φ12.7 x 10.8	φ9.5 x 10.8																																																																																																					
50 or more to 100 (100 excluded)	φ9.5 x 10.8	φ15.9 x 11.0	φ12.7 x 10.8																																																																																																					
100 or more to 160 (160 excluded)	φ9.5 x 10.8	φ19.1 x 11.0	φ15.9 x 11.0																																																																																																					
160 or more to 330 (330 excluded)	φ12.7 x 10.8	φ25.4 x 11.2	φ19.1 x 11.0																																																																																																					
330 or more to 480 (480 excluded)	φ15.9 x 11.0	φ34.9 x 11.3	φ25.4 x 11.2																																																																																																					
480 or more to 640 (640 excluded)	φ19.1 x 11.0	φ34.9 x 11.3	φ25.4 x 11.2																																																																																																					
640 or more to 700 (700 excluded)	φ19.1 x 11.0	φ41.3 x 11.7	φ25.4 x 11.2																																																																																																					
700 or more	φ19.1 x 11.0	φ41.3 x 11.7	φ34.9 x 11.3																																																																																																					
Indoor unit capacity sum of indoor units	Pipe size (Outer diameter x minimum wall thickness)																																																																																																							
* 20 · 25 · 32 · 40	φ12.7 x 0.8																																																																																																							
50 · 63 · 80	φ15.9 x 1.0																																																																																																							
100 · 125	φ19.1 x 1.0																																																																																																							
200	φ25.4 x 1.2																																																																																																							
250	φ28.6 x 1.2																																																																																																							
Outline of how to computer quantity of refrigerant to be charged additionally.		<p>When using BR2K (E) function unit</p> <p>Quantity of additional charge (kg) = <math>\frac{\text{Total length of 19.1mm dia. liquid line}}{(m) \times 0.27} \times 0.27 + \frac{\text{Total length of 15.9mm dia. liquid line}}{(m) \times 0.17} \times 0.17 + \frac{\text{Total length of 12.7mm dia. liquid line}}{(m) \times 0.1} \times 0.1 + \frac{\text{Total length of 9.5mm dia. liquid line}}{(m) \times 0.05} \times 0.05 + \frac{\text{Total length of 6.4mm dia. liquid line}}{(m) \times 0.025} \times 0.025 + 6</math></p> <p>When using BR3K (E) function unit</p> <p>Quantity of additional charge (kg) = <math>\frac{\text{Total length of 22.2mm dia. liquid line}}{(m) \times 0.36} \times 0.36 + \frac{\text{Total length of 19.1mm dia. liquid line}}{(m) \times 0.27} \times 0.27 + \frac{\text{Total length of 15.9mm dia. liquid line}}{(m) \times 0.17} \times 0.17 + \frac{\text{Total length of 12.7mm dia. liquid line}}{(m) \times 0.1} \times 0.1 + \frac{\text{Total length of 9.5mm dia. liquid line}}{(m) \times 0.05} \times 0.05 + \frac{\text{Total length of 6.4mm dia. liquid line}}{(m) \times 0.025} \times 0.025 + 8</math></p> <p>* Addition refrigerant charge. 0.1 kg (Round off to nearest 1/10th)</p>		<p>(Example) For refrigerant branch ② using REFNET joint and REFNET header</p> <p>a: φ12.7 x 10m   d: φ22.2 x 30m   g: φ12.7 x 9m   j: φ6.4 x 4m   m: φ6.4 x 5m   q: φ12.7 x 7m   e: φ15.9 x 5m   h: φ12.7 x 10m   k: φ6.4 x 5m   n: φ9.5 x 5m   r: φ12.7 x 4m   f: φ15.9 x 9m   i: φ15.9 x 10m   l: φ6.4 x 5m   p: φ9.5 x 5m   s: φ12.7 x 4m</p> <p>30 x 0.36 + 20 x 0.17 + 40 x 0.1 + 50 x 0.05 + 19 x 0.025 + 6 = 19.175 kg</p>																																																																																																				

### (3) Field refrigerant piping VRV PLUS Series – Heat Pump and Cooling only model

(1) The following materials should be used for all refrigerant piping:

- Materials: Deoxidized phosphorous seamless copper pipe

(for external diameters of 25.4mm or more G1230T 0.6)

Все каталоги и инструкции здесь: <https://splitsystema48.ru/instrukcii-po-ekspluatacii-kondicionerov.html>

(2) The tips for insulation:

- Gas piping must be insulated.
- If it is considered likely that the air conditioner will be operated at temperatures between 0°C and 10°C in cooling mode then the liquid pipes must also be insulated.
- Materials: Glass fiber or heat resistant polyethylene foam.  
Thickness: 10mm or more  
Heat resistance: Gas pipe – 120°C or more/  
Liquid pipe – 70°C or more

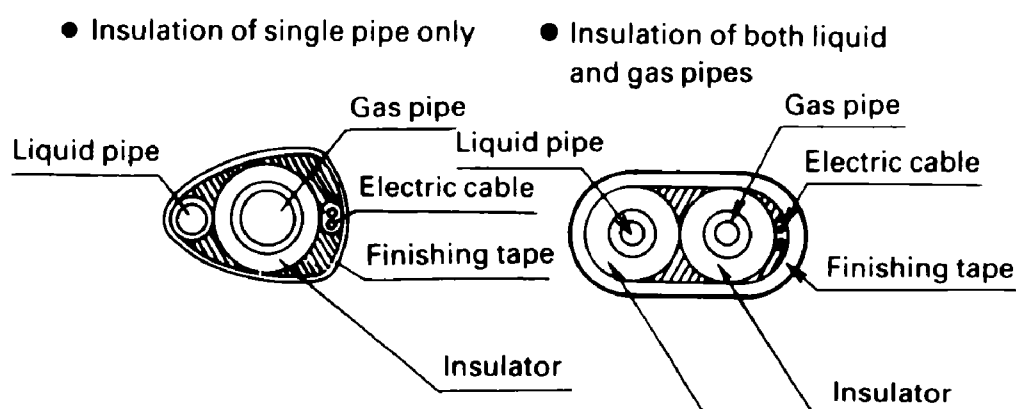

### (4) Field refrigerant piping VRV PLUS Series – Heat Recovery

- Example of thermal insulation work
- 3 piping section (between outdoor unit and BS unit)

- 2 piping section (between BS unit and indoor unit)

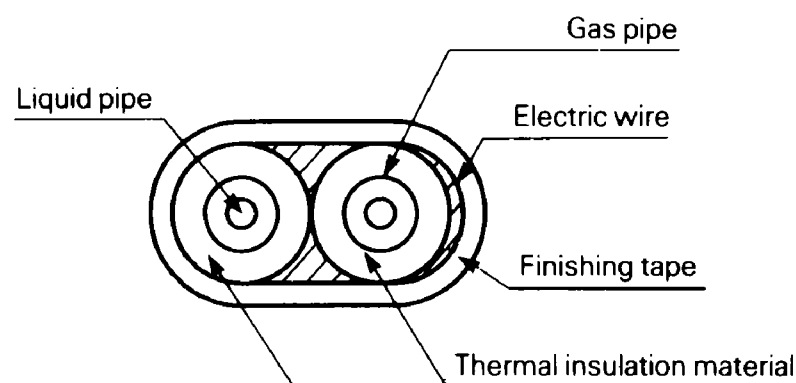
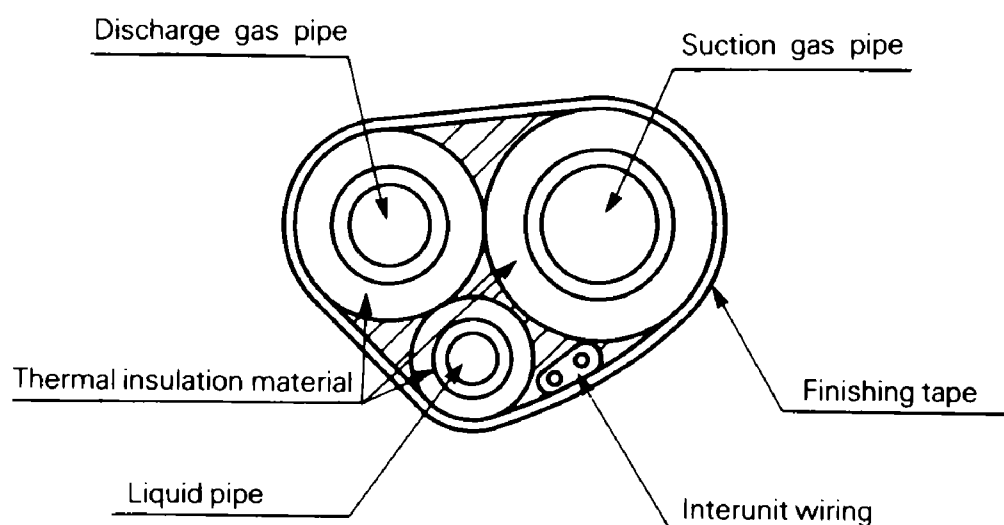

#### Key point 1

Normally only the gas pipes between the BS unit and the indoor unit are thermally insulated, but in cases where the cooling function may be used at outdoor air temperatures of between -5.0°C and +10°C, it is necessary that the liquid pipes are also thermally insulated.

(As the outdoor air temperature falls so too does the temperature of the refrigerant in the liquid pipes. If, under these circumstances, the moisture content in the air condenses out onto the surface of the piping and then drips, this could result in water leaks from the unit)

#### Key point 2

Unlike the Inverter Series, there are three pipes connecting the outdoor unit and the BS unit and it is therefore of particular importance to ensure that the piping connections are all made correctly.

# 13. Electrical Work for Power Supply

## Rough drawings

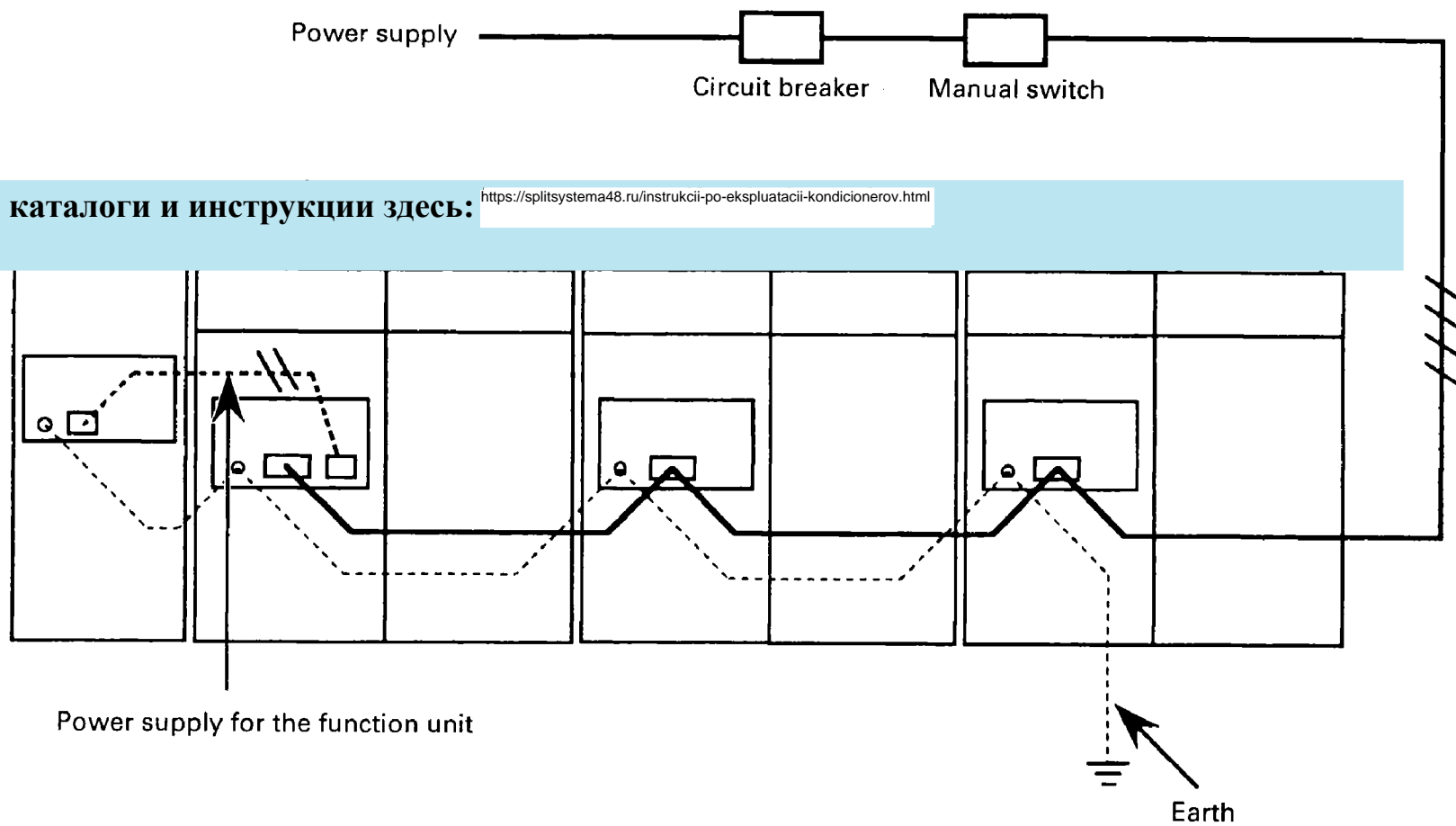

Все каталоги и инструкции здесь: <https://splitsystema48.ru/instrukcii-po-ekspluatacii-kondicionerov.html>

## Switch box

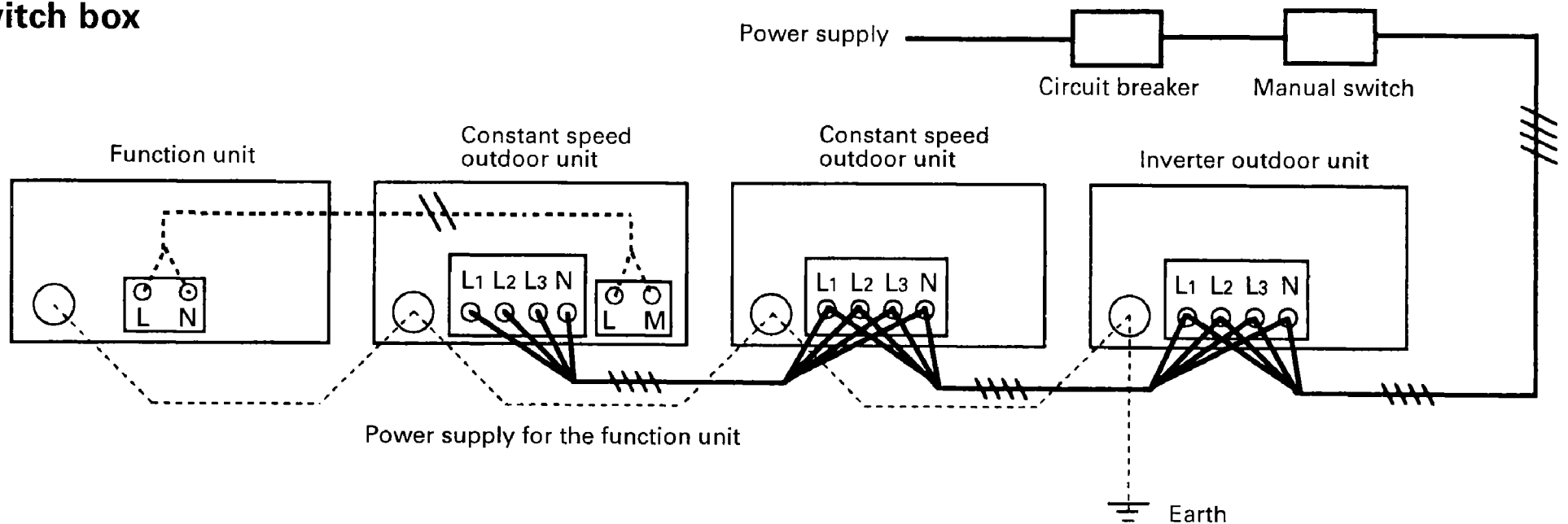

### Terminal block (Inverter type outdoor unit)

Terminal block capacity of the outdoor unit is all same. Therefore power supply wiring can be connected from any outdoor unit.

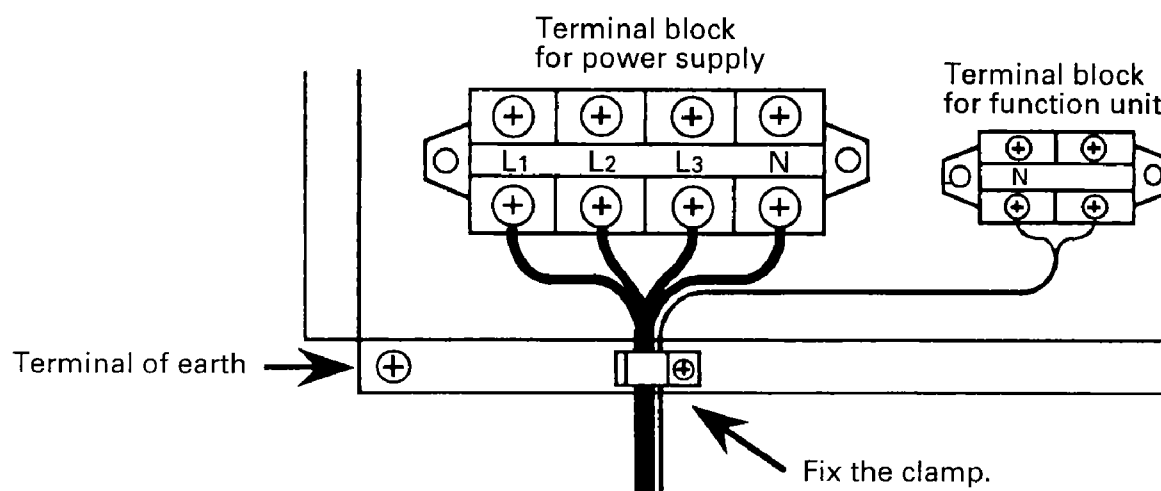

### Work points

- Connect power supply wiring for the outdoor unit and the function unit as shown above. However, connect small capacity outdoor unit at downstream. (Please refer to the engineering data about detail.)
- Be sure to connect power supply wiring to the terminal block and cramp it.
- Do not attach phase advance condenser.



# 14. Electrical Work for Transmission Line

## EXAMPLE OF TRANSMISSION WIRING

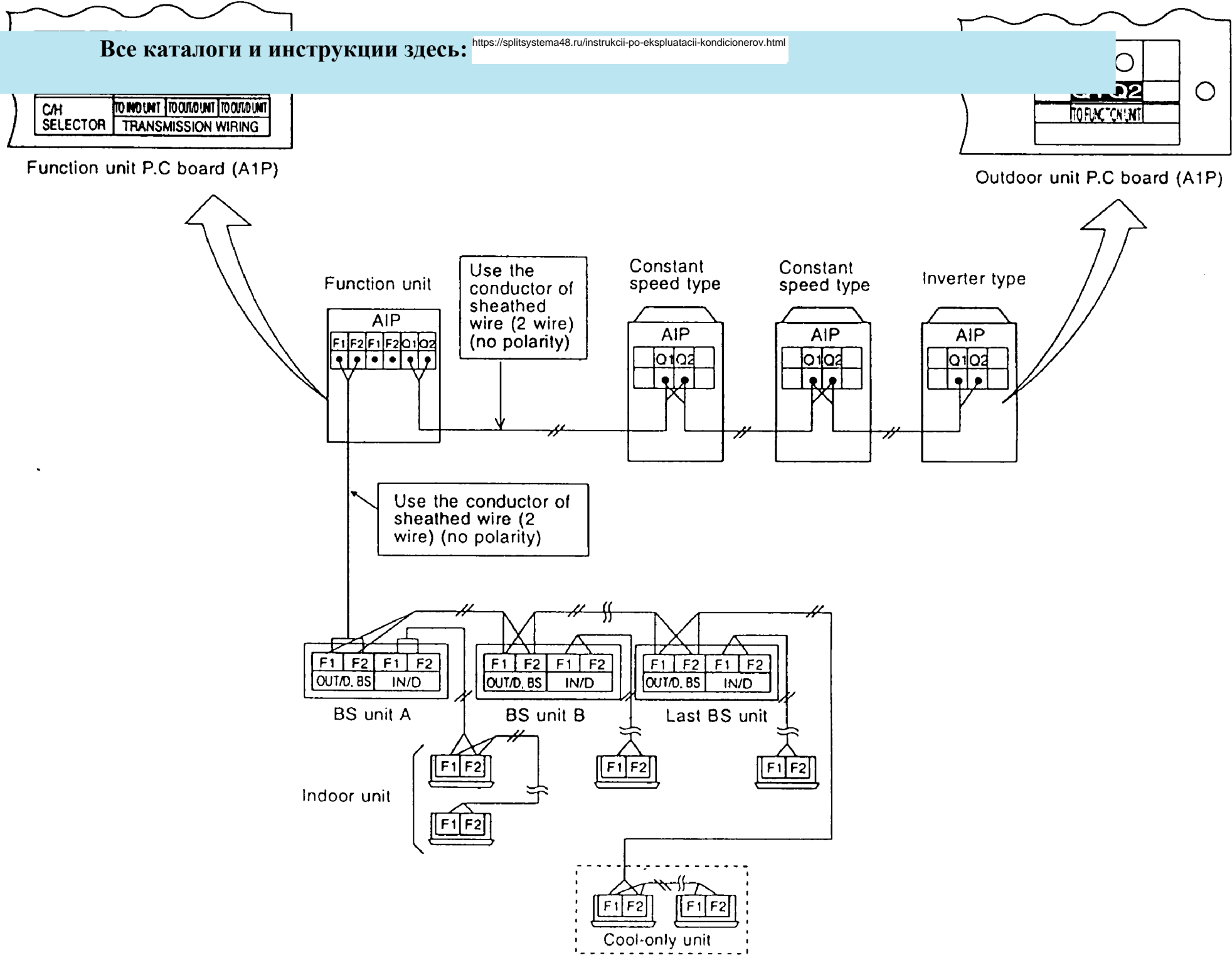

### (CAUTIONS)

- Be sure to follow the limits below. If the unit-to-unit cables are beyond these limits, it may result in malfunction of transmission.
  - Max wiring length: 1000m
  - Total wiring length: 2000m
  - Max branches No. of branches: 16
  - Max. number of outdoor units: 10
- Do not include the function unit in the number of connected units. (Ex. The REY30KY1 takes 3 outdoor units.)
- Up to 16 branches are possible for unit-to-unit cabling. No branching is allowed after branching.

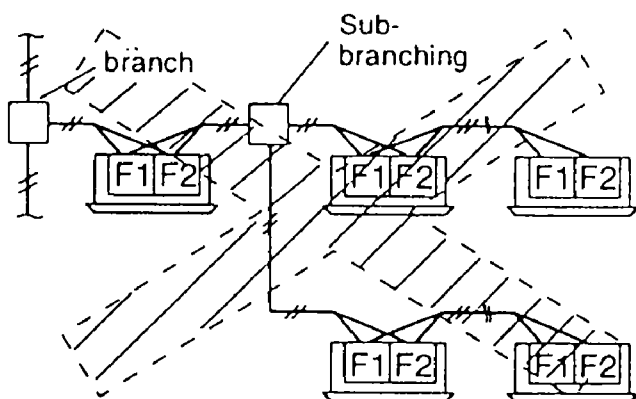

- Never connect the power supply to the unit-to-unit cabling terminal block. Otherwise the entire system may break down.

# 15. Switch Settings according to Number of Outdoor Units

- With the BL3K, BC3K and BR3K, set the OUT/D UNIT selector switch (SS3) on the function unit PC board according to the number of outdoor units in the system.

Set the switch before turning ON the power.

(1) For 3 outdoor units

Leave the OUT/D UNIT selector switch (SS3) at the factory setting.

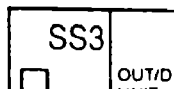

Все каталоги и инструкции здесь: <https://splitsystema48.ru/instrukcii-po-ekspluatacii-kondicionerov.html>

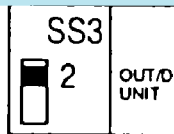

- Set switch SS2 on the PC board for constant speed type ① and ② as shown below.

(1) With 3 outdoor units

(2) With 2 outdoor units

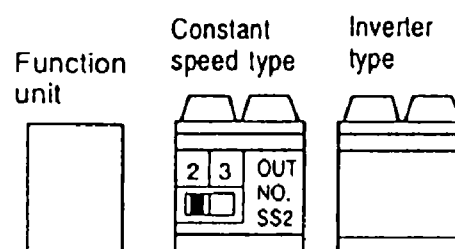
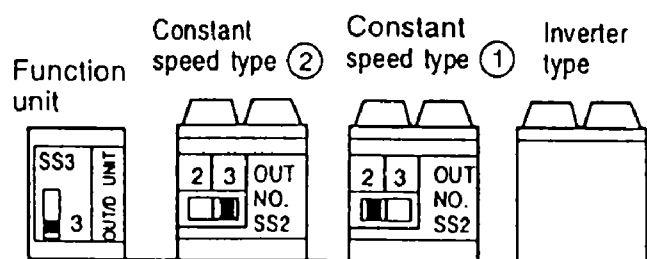

- Note) 1. Switch SS2 on constant speed type is factory-set to "2".  
 2. Observe the following when using 3 outdoor units.  
 Constant speed type ① capacity  $\geq$  Constant speed type ② capacity

**NOTE:** There is no switch for setting the number of outdoor units (SS3) for BL2K, BC2K and BR2K.

# 16. Test Operation

## 1 Procedure and points

The operation sequence is the most important thing for test operation. Follow the following outline.

### (1) Check the following before turning power on.

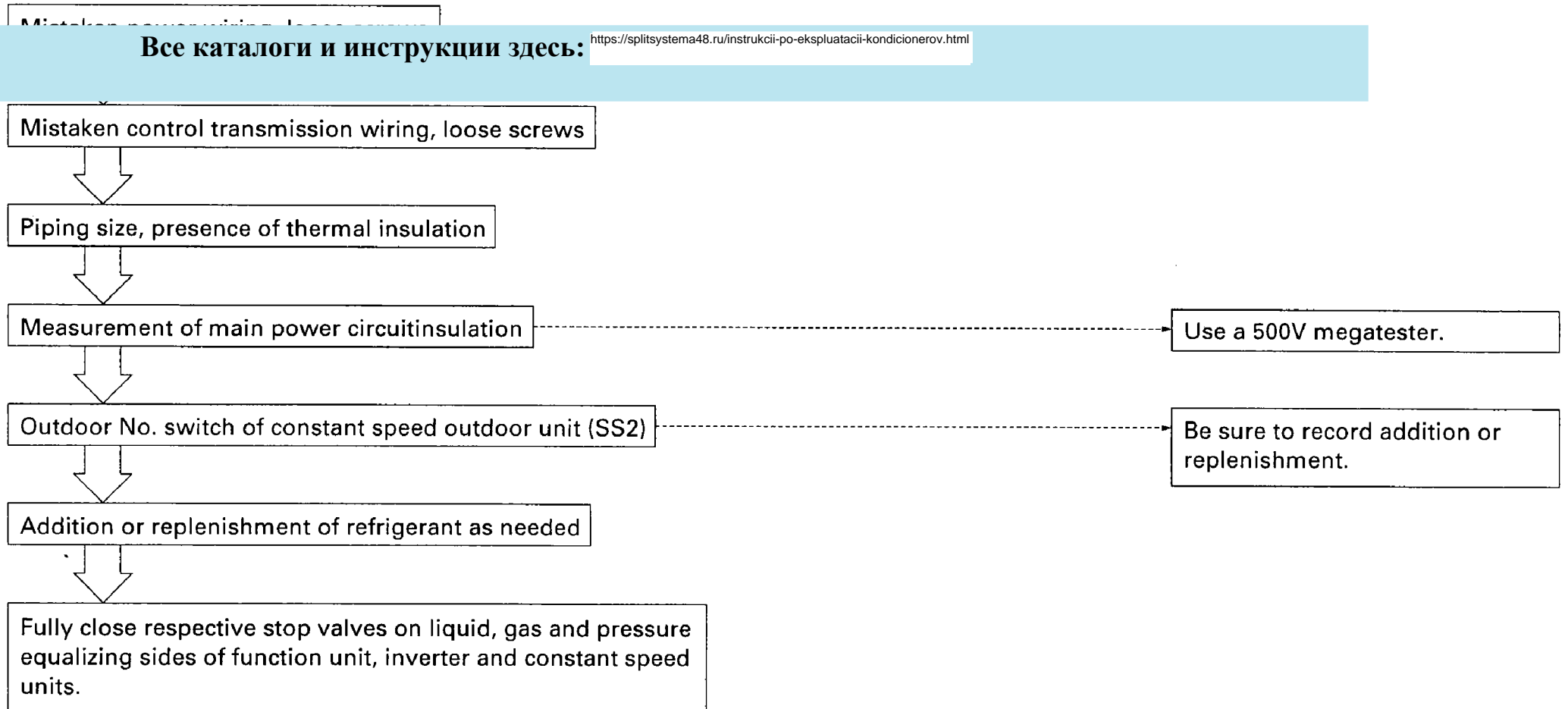

### (2) Turn power on.

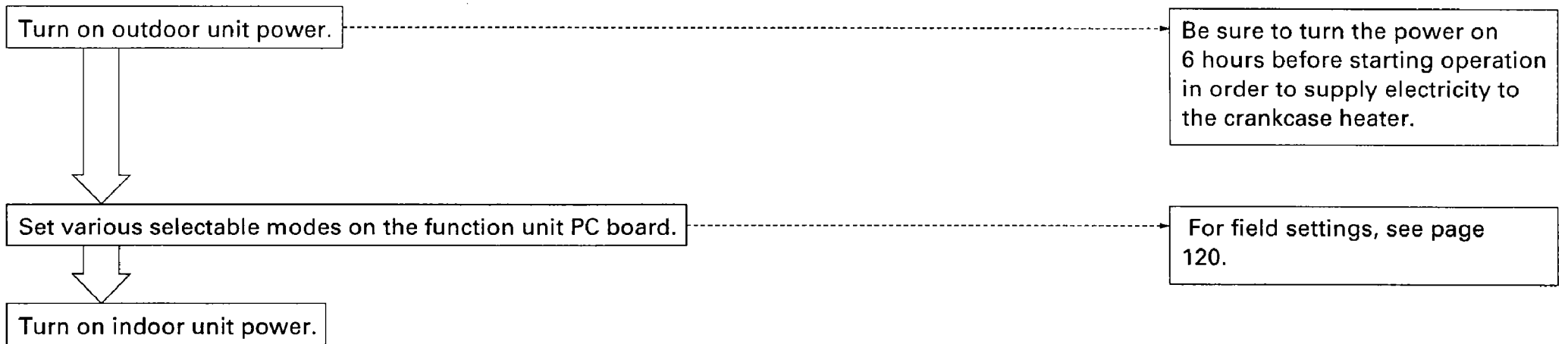

### (3) Check operation.

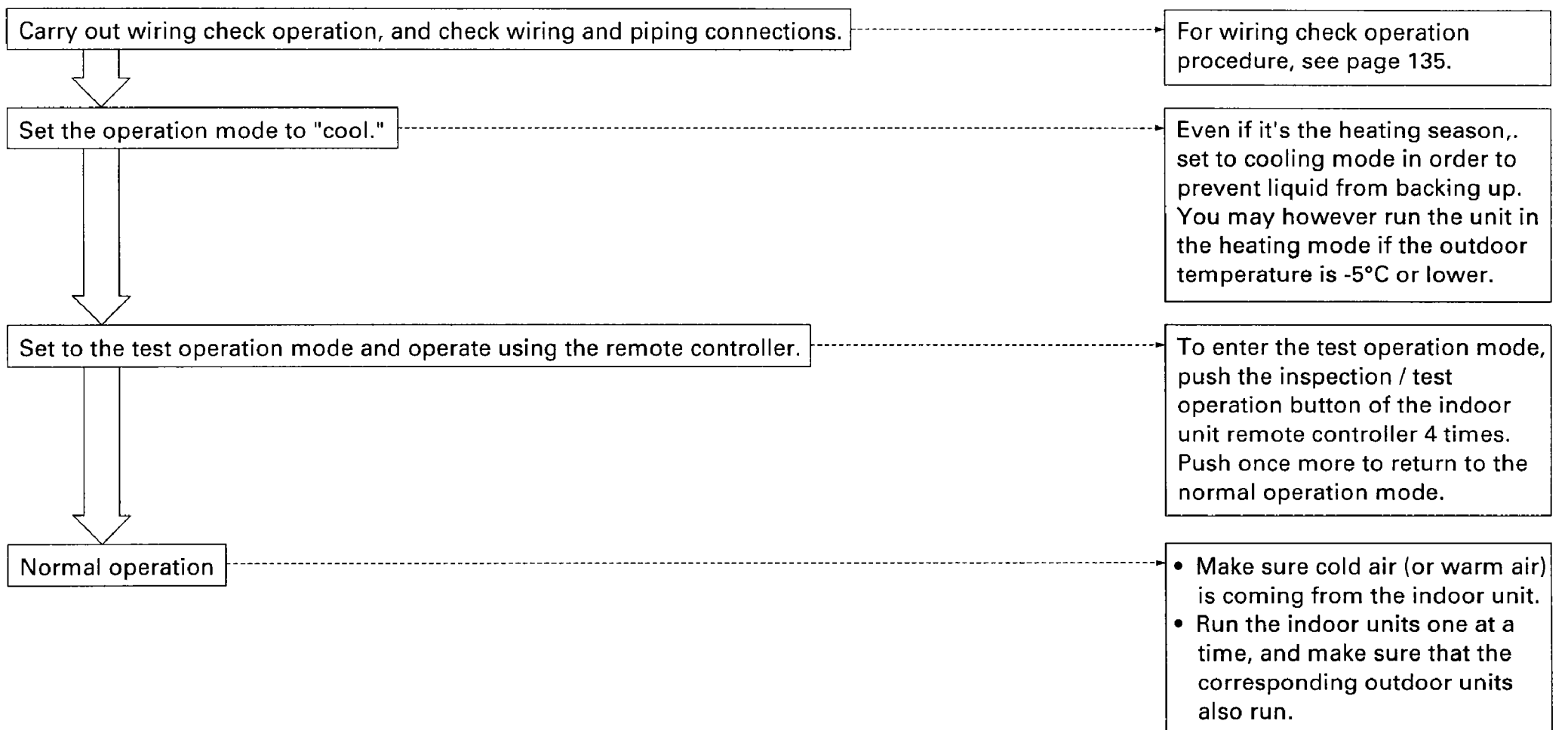

## 2 Action when Power On

### \*When turning on power for first time

The unit cannot be run for up to 12 minutes to automatically set the master power and address (indoor-outdoor address, etc.).

Все каталоги и инструкции здесь: <https://splitsystema48.ru/instrukcii-po-ekspluatacii-kondicionerov.html>

- Outdoor unit ...Warning lamp (HWL) lights
- Indoor unit.....If ON button is pushed during operation described above, the "UH" malfunction indicator blinks.  
(Returns to normal when automatic setting is complete.)

### \*When turning on power the second time and subsequent

Tap the wiring change button on the function unit PC board. Operation becomes possible after setting up for about 2 minutes. If you do not push the wiring change button, the unit cannot be run for up to 10 minutes to automatically set master power.

- Function unit ..Test lamp (H2P)  
Can also be set during operation described above.
- Outdoor unit ...Warning lamp (HWL) lights
- Indoor unit.....If ON button is pushed during operation described above, the operation lamp lights but the compressor does not operate. (Returns to normal when automatic setting is complete.)

### \*When an outdoor unit, indoor unit or BS unit has been added, or indoor unit PC Board has been changed

Be sure to push and hold the wiring change button for 5 seconds or longer. If not, the addition cannot be recognized. In this case, the unit cannot be run for up to 12 minutes to automatically set the address (indoor-outdoor address, etc.).

- Function unit....Test lamp (H2P) goes off
- Outdoor unit ...Warning lamp (HWL) lights
- Indoor unit.....If ON button is pushed during operation described above, the "UH" or "U4" malfunction indicator blinks.  
(Returns to normal when automatic setting is complete.)

#### [NOTE]

##### Concerning compressor frequency when starting

Starting control is executed to stop operation frequency from rising to protect the compressor, and is carried out in accordance with the time elapsed since turning on the power, how long the compressors have been stopped, and outdoor temperature. The operating frequency of the compressor is held down during this time, and is not a malfunction.

(1) When cooling: Max. 7 minutes if outdoor temp. is low

(2) When heating: Max. 33 minutes if starting first time since turning power on

Max. 15 minutes is starting second time or subsequent since turning power on

### 3 Function Unit / Outdoor Unit P.C Board Ass'y

■ Function unit

BL BC

■ Outdoor unit (Inverter type)

RXY

Outdoor unit external control adaptor (CN24)

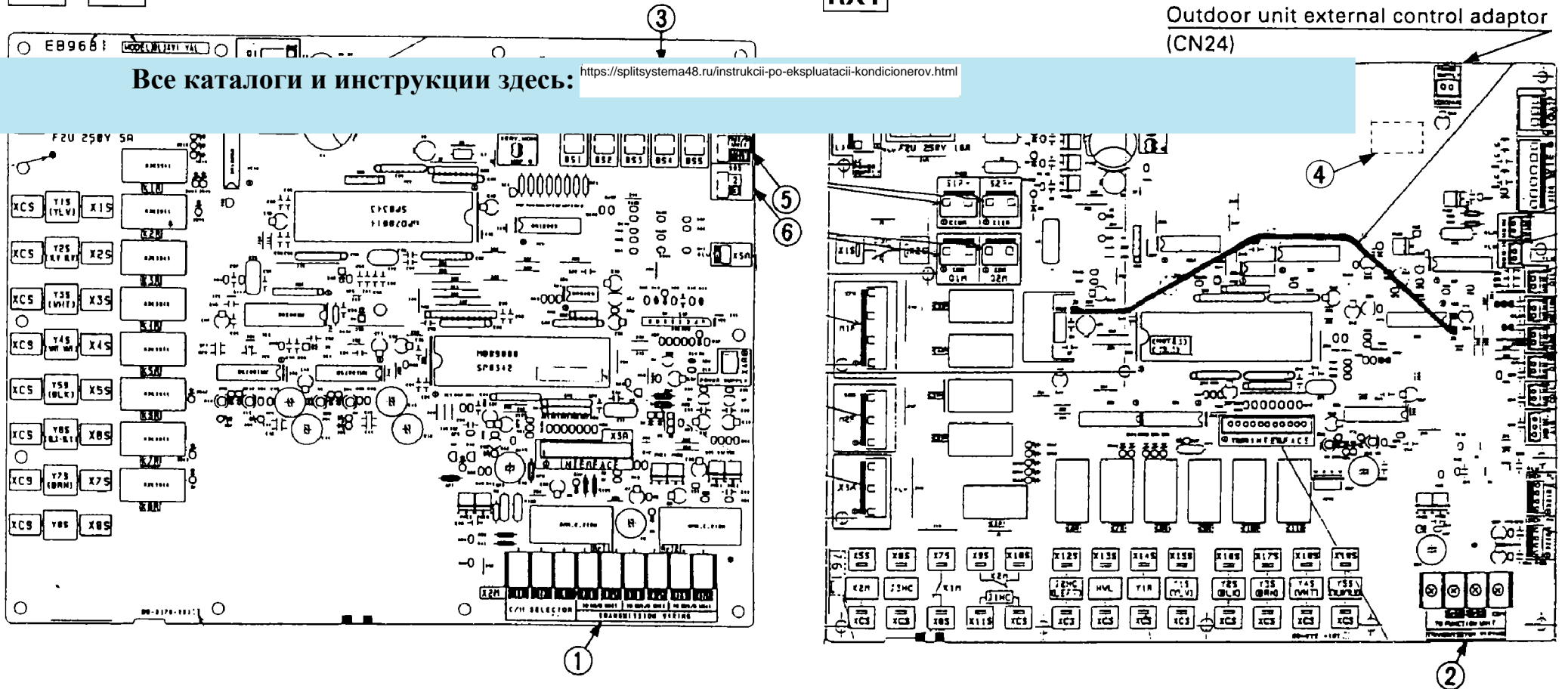

①	<p>Transmission terminal (Indoor unit, Cool/Heat selector) Outdoor - Outdoor</p> <p>Note: The R unit is not provided with the cool/heat select remote control terminals.</p>	
②	<p>Transmission terminal (Function unit - Each outdoor unit) Series connection</p>	
③	<p>Function of setting mode</p>	
④	<p>Outdoor unit No. setting (SS2)</p> <p>Note: This setting is not available on the inverter type</p>	<p>Pre-settable for constant-speed outdoor unit only: 2: Second unit, 3: Third unit</p>
⑤	<p>Function of setting between cooling and heating (※ Except for Cooling only system)</p>	
⑥	<p>Outdoor unit connections setting (SS3)</p> <p>Note: This setting is not available on the BL2K and BR2K.</p>	<p>Set the number of outdoor units being connected.</p>

## 4 Setting Modes

There are the following three setting modes.

- ① Setting mode 1 (H1P off): Used to select the cool/heat setting, low-noise run and sequential start.
- ② Setting mode 2 (H1P on): Used to modify the running status and to program addresses, etc. Usually used in

Все каталоги и инструкции здесь: <https://splitsystema48.ru/instrukcii-po-ekspluatacii-kondicionerov.html>

of units being

### Functions of pushbutton switches

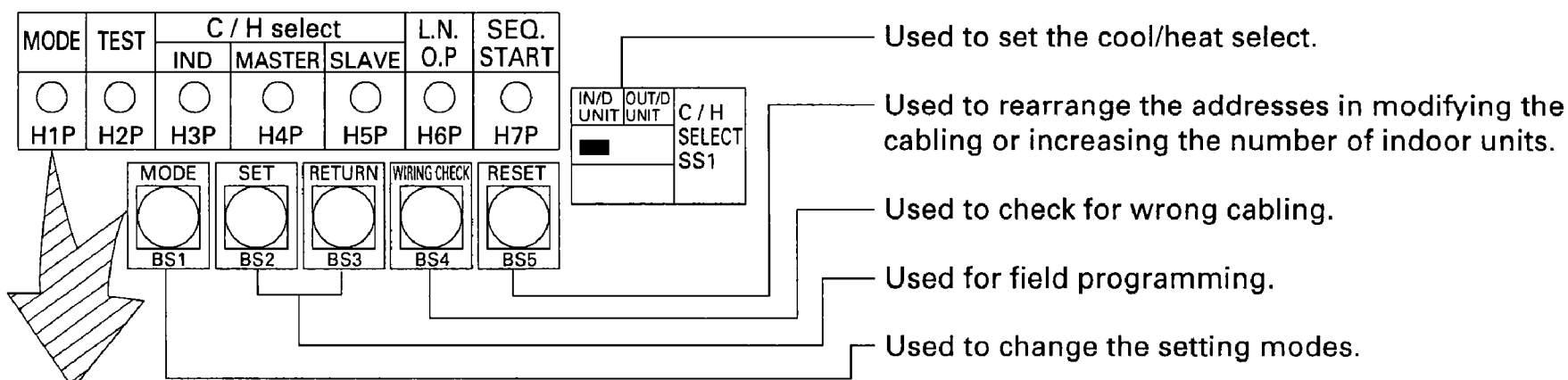

### Mode change

Using the MODE button, the modes can be changed as follows.

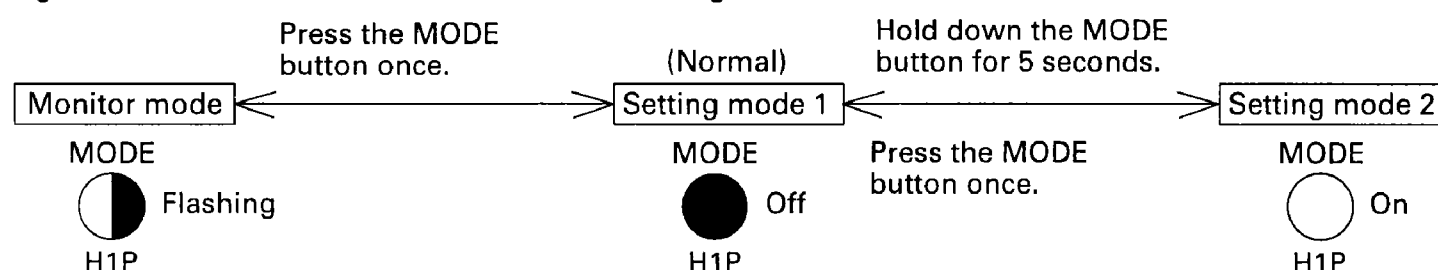

### Mode changing procedure

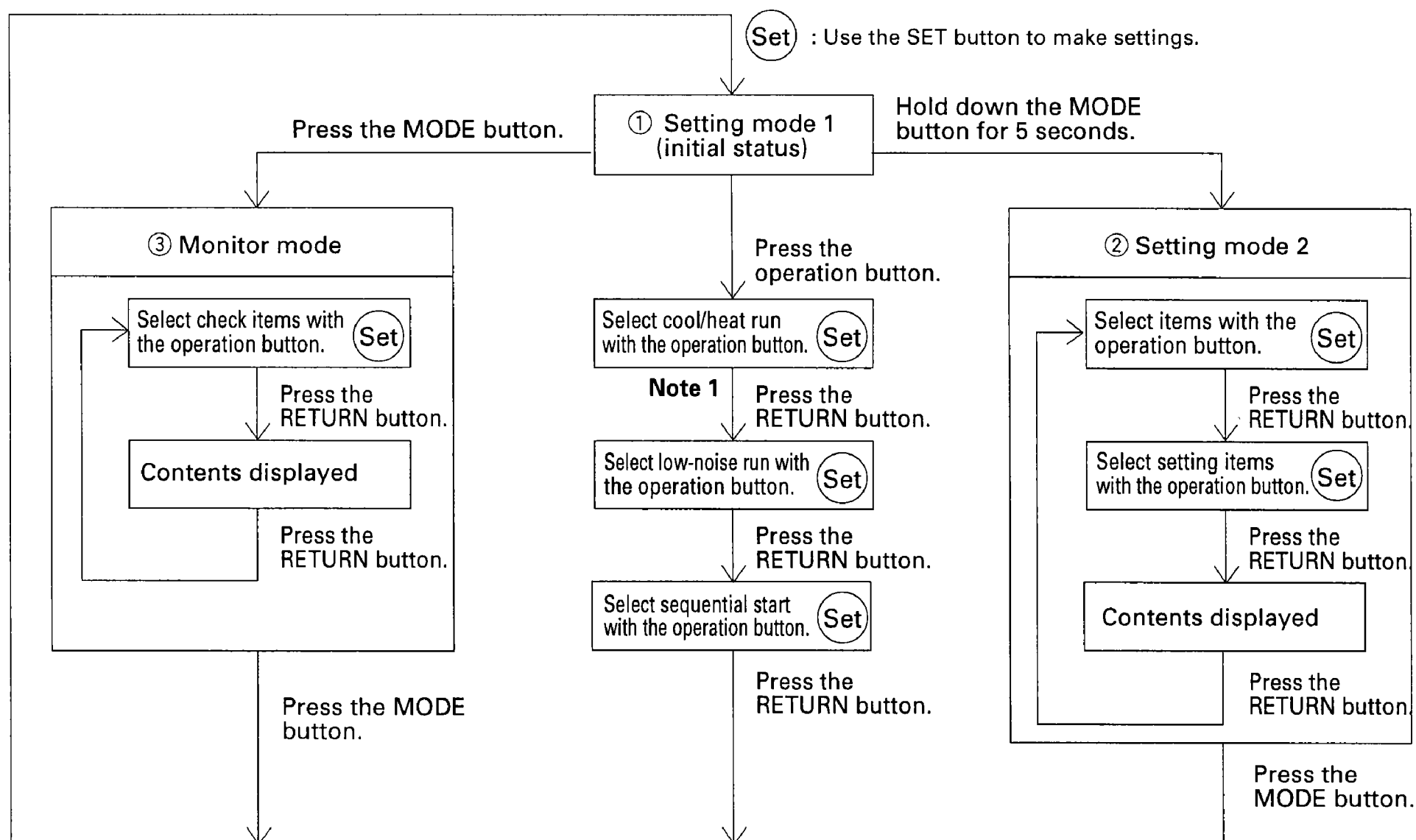

Note 1 : No cool / Heat selection for cooling only system.

# (1) Setting Mode 1

Cool/heat selection setting (SS1) If carried out from the indoor unit remote controller: If carried out from the cool/heat selector:

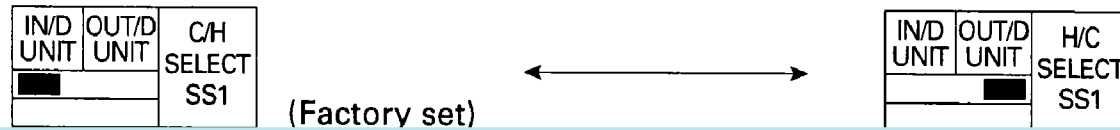

Все каталоги и инструкции здесь: <https://splitsystema48.ru/instrukcii-po-ekspluatacii-kondicionerov.html>

MODE	TEST	C/H SELECT			L.N.O.P.	SEQ. START
		IND	MASTER	SLAVE		
H1P	H2P	H3P	H4P	H5P	H6P	H7P

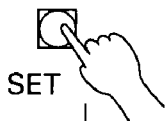

The factory settings are:  
 Individual (C/H SELECT), OFF (L.N.O.P.), ON (SEQ. START)  
 You can change the cool/heat selection permission, low noise and sequential start settings by pushing the SET switch.  
 To skip settings you don't want to change, push the RETURN switch and go to the next setting.

Change cool/heat selection to MASTER.

An optional adaptor for outside control of outdoor units is required if you have set cool/heat selection to MASTER or SLAVE.

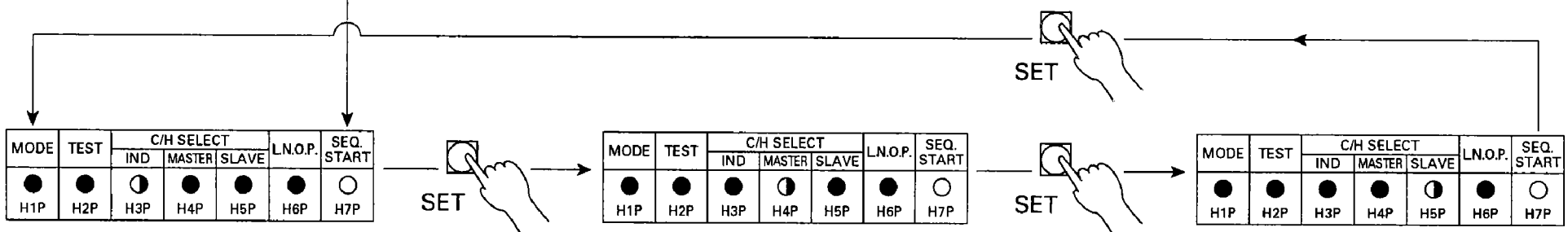

Change low noise operation to "ON".

External control adaptor for outdoor unit is required if low noise operation is set to "ON".

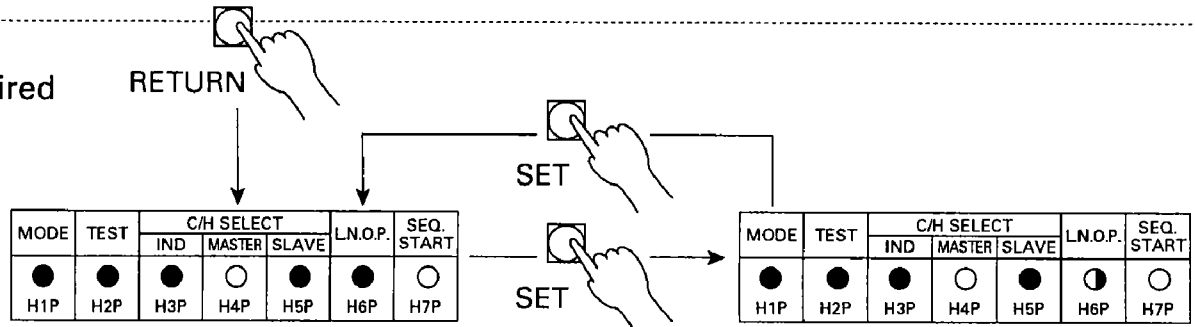

Change sequential start to "OFF".

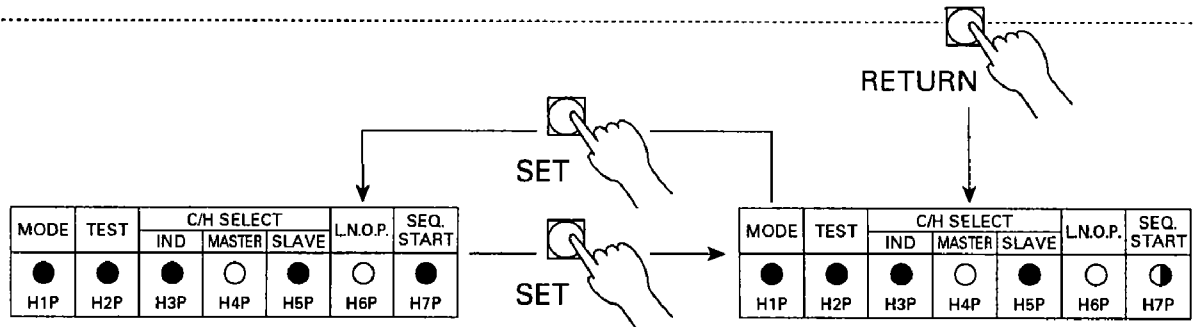

Setting complete

GROUP MASTER (cool/heat selection), ON (low noise), OFF (sequential start)

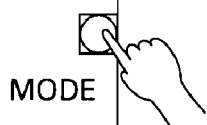
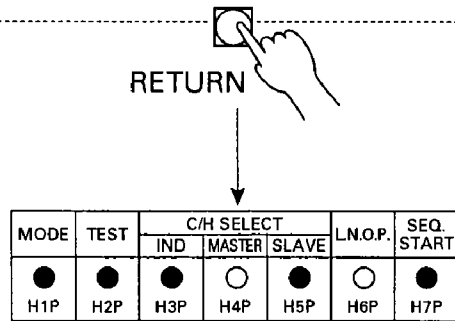

Monitor mode

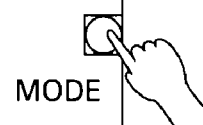

Push and hold for 5 sec.

Setting mode 2

**NOTE:** 1. External control adaptor for outdoor unit is required if cool/heat selection set to MASTER or SLAVE, or if low noise operation is set to ON.

## (2) Setting Mode 2

To switch from setting mode 1 (normal) to setting mode 2, you must push and hold the next page button (BS1) for 5 seconds. (You cannot enter setting mode 2 while setting mode 1 is set.)

### Setting procedure

### Setting items

Все каталоги и инструкции здесь: <https://splitsystema48.ru/instrukcii-po-ekspluatacii-kondicionerov.html>

- (LED display). (All 10 settings)
- ↓
- ② Push the RETURN button (BS3) and the present settings flicker (LED display).
- ↓
- ③ Push the SET button (BS2) and match with each setting (LED flicker display).
- ↓
- ④ Push the RETURN button (BS3) and enter the settings.
- ↓
- ⑤ Push the RETURN button (BS3) and return to the initial status.

Note: ● If you become unsure of how to proceed, push the MODE button (BS1) and return to setting mode 1.

- The initial status of setting mode 2 is the status of setting item No. 1 in mode 2.

**Note 1:**  
TC setting and Defrost setting are not applicable to cooling only system.

					LED display							
					H1P	H2P	H3P	H4P	H5P	H6P	H7P	
<p>1</p> <p>EMG (Emergency operation 1)</p> <p>Emergency operation when inverter type outdoor unit malfunctions.</p> <p>○ ● ● ● ● ● ●</p> <p>○ ● ● ● ● ● ● ●</p>	Emergency operation	○ ● ● ● ● ● ●	(Operates by constant speed outdoor unit only.)	Normal operation	○ ● ● ● ● ● ●	○						
	<p>2</p> <p>Cool/heat unified address</p> <p>Address for cool/heat unified operation</p> <p>○ ● ● ● ● ● ○</p>	Address	0	○ ● ● ● ● ● ● ●	Binary number	1	○ ● ● ● ● ● ●	○				
		2	○ ● ● ● ● ● ○ ●	}	31	○ ● ○ ○ ○ ○ ○ ○						
		31	○ ● ○ ○ ○ ○ ○ ○									
		3 <p>Low noise / demand address</p> <p>Address for low noise / demand operation.</p> <p>○ ● ● ● ● ● ○ ●</p>	Address	0	○ ● ● ● ● ● ● ●	Binary number	1	○ ● ● ● ● ● ●	○			
	2	○ ● ● ● ● ● ○ ●	}	31	○ ● ○ ○ ○ ○ ○ ○							
	31	○ ● ○ ○ ○ ○ ○ ○										
	<p>4</p> <p>Forced fan switch</p> <p>Indoor unit fan turns while unit is stopped.</p> <p>○ ● ● ● ○ ● ○</p>	Forced fan operation (H tap)	○ ● ● ● ● ● ○ ●	Normal operation	○ ● ● ● ● ● ●	○						
		<p>5</p> <p>Indoor unit forced operation</p> <p>Allows operation of indoor unit from outdoor unit.</p> <p>○ ● ● ● ○ ○ ●</p>	Indoor unit forced operation	○ ● ● ● ● ● ○ ●	Normal operation	○ ● ● ● ● ● ●	○					
	<p>6</p> <p>Frequency fix</p> <p>Fixes compressor frequency. INV : (60Hz+OFF) STD1: (ON+OFF) STD2: (ON+OFF)</p> <p>○ ● ● ● ○ ○ ○</p>		Frequency fix	○ ● ● ● ● ● ○ ●	Normal operation	○ ● ● ● ● ● ●	○					
		<p>7</p> <p>TE setting</p> <p>Low pressure setting for cooling.</p> <p>○ ● ● ○ ● ● ○</p>	High	○ ● ● ● ● ○ ● ●	Normal (factory set)	○ ● ● ● ● ● ○ ●						
	<p>8</p> <p>TC setting</p> <p>High pressure setting for heating</p> <p>○ ● ● ○ ● ○ ●</p> <p><b>Note 1</b></p>		Low	○ ● ● ● ● ● ○								
		<p>9</p> <p>Defrost setting</p> <p>Temperature setting for defrost.</p> <p>○ ● ● ○ ○ ● ○</p> <p><b>Note 1</b></p>	Quick defrost	○ ● ● ● ● ○ ● ●	Normal (factory set)	○ ● ● ● ● ● ○ ●	○					
	<p>10</p> <p>Air NET address</p> <p>Address for Air NET</p> <p>○ ● ● ○ ○ ● ○</p>		Address	0	○ ● ● ● ● ● ● ●	Binary number	1	○ ● ● ● ● ● ●	○			
2			○ ● ● ● ● ● ○ ●	}	63	○ ○ ○ ○ ○ ○ ○ ○						
<p>11</p> <p>Pump down operation 1</p> <p>Pump down operation of INV outdoor unit.</p> <p>○ ● ● ○ ○ ○ ●</p>	Pump down operation	○ ● ● ● ● ● ○ ●										
		<p>12</p> <p>Pump down operation 2</p> <p>Pump down operation of STD 1 outdoor unit.</p> <p>○ ● ● ○ ○ ○ ○</p>	Normal operation	○ ● ● ● ● ● ●	○							
			<p>13</p> <p>Pump down operation 3</p> <p>Pump down operation of STD 2 outdoor unit.</p> <p>○ ● ○ ● ● ● ●</p>									
<p>14</p> <p>Forced backup operation (Emergency operation 2)</p> <p>Executes emergency operation when constant speed outdoor unit is faulty.</p> <p>○ ● ○ ● ○ ● ●</p>	When constant speed outdoor unit 2 is faulty:	○ ● ● ● ● ○ ● ●	When constant speed outdoor unit 1 is faulty:	○ ● ● ● ● ● ○	○							
	Normal operation	○ ● ● ● ● ● ●										
		○ ● ● ● ● ● ○										



No	Setting item	Description	LED display H1P H2P H3P H4P H5P H6P H7P	LED display H1P H2P H3P H4P H5P H6P H7P	LED display H1P H2P H3P H4P H5P H6P H7P
1	EMG (Emergency operation 1)	Emergency operation when Inverter type outdoor unit malfunctions.		Emergency operation Normal operation	
2	Cool/heat	Address for		Address 0 Binary number 1 (6 digits) 2 31	
3	Low noise / demand address	Address for low noise / demand operation		Address 0 Binary number 1 (6 digits) 2 31	
4	Forced fan switch	Indoor unit fan turns while unit is stopped.		Forced fan operation (H tap) Normal operation	
5	Indoor unit forced operation	Allows operation of indoor unit from outdoor unit		Forced fan operation (H tap) Normal operation	
6	Frequency fix	Fixes compressor frequency. INV : (60Hz+OFF) STD 1 : (ON+OFF) STD 2 : (ON+OFF)		Frequency fix Normal operation	
7	TE setting	Low pressure setting for cooling		High Normal (factory set) Low	
8	TC setting Note 1	High pressure setting for heating		Quick defrost Normal (factory set) Slow defrost	
9	Defrost setting Note 1	Temperature setting for defrost		Address 0 Binary number 1 (6 digits) 2 63	
10	Air Net address	Address for Air Net		Pump down operation Normal operation	
11	Pump down operation 1	Pump down operation of INV outdoor unit		Constant speed outdoor unit 2 has broken Constant speed outdoor unit 1 has broken Normal operation	
12	Pump down operation 2	Pump down operation of STD 1 outdoor unit			
13	Pump down operation 3	Pump down operation of STD 2 outdoor unit			
14	Forced back up operation (Emergency operation 2)	Executes emergency operation when constant speed outdoor unit is faulty.			

Все каталоги и инструкции здесь: <https://splitsystema48.ru/instrukcii-po-ekspluatacii-kondicionerov.html>

Initial setting (EMG)

Initial setting (EMG)

RETURN BUTTON  
 SET BUTTON

### (3) Monitor Mode

MODE	TEST	C/H SELECT			L.N.O.P.	SEQ. START
		IND	MASTER	SLAVE		
<input checked="" type="radio"/> H1P	<input checked="" type="radio"/> H2P	<input type="radio"/> H3P	<input checked="" type="radio"/> H4P	<input checked="" type="radio"/> H5P	<input checked="" type="radio"/> H6P	<input type="radio"/> H7P

To enter the monitor mode, push the MODE button when in setting mode 1.

Все каталоги и инструкции здесь: <https://splitsystema48.ru/instrukcii-po-ekspluatacii-kondicionerov.html>

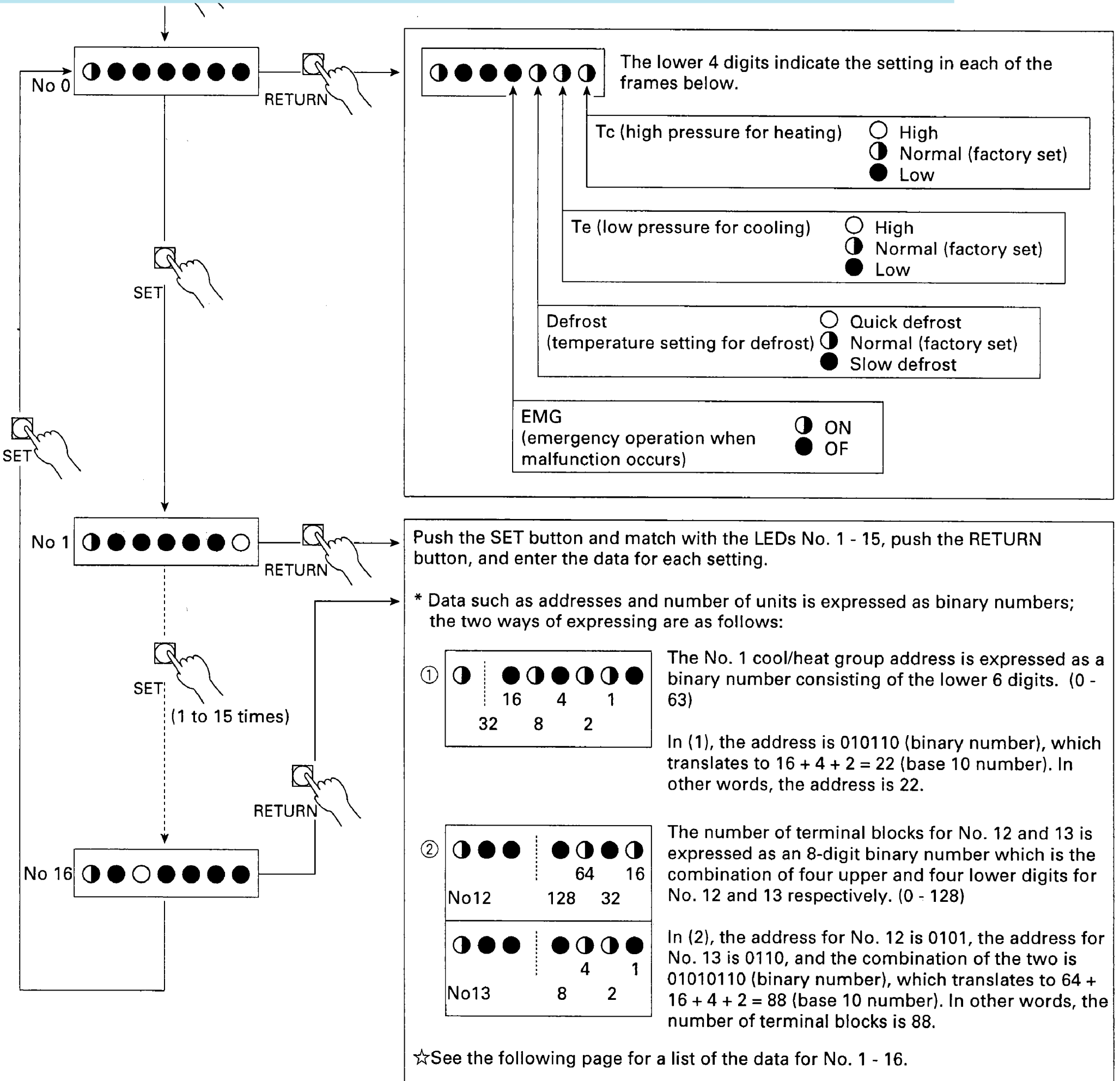

☆ After making sure the data is correct, push the RETURN button and return to No. 0, or push the MODE button and return to setting mode 1.

● Monitor Mode Data

Mode No.	LED	Data	Display method	Size (binary number)
No 1	● ● ● ● ● ● ○	Cool/heat group address	0 ~ 31	Lower 6 digits
No 2	● ● ● ● ● ○ ●	Low noise / demand address	0 ~ 31	Lower 6 digits
No 3	○ ● ● ● ● ○ ○	Not used		
<p>Все каталоги и инструкции здесь: <a href="https://splitsystema48.ru/instrukcii-po-ekspluatacii-kondicionerov.html">https://splitsystema48.ru/instrukcii-po-ekspluatacii-kondicionerov.html</a></p>				6 digits
No 5	○ ● ● ● ○ ● ○	Number of connected units	0 ~ 63 units	Lower 6 digits
No 6	○ ● ● ● ○ ○ ●	Number of connected BS units	0 ~ 63 units	Lower 6 digits
No 7	○ ● ● ● ○ ○ ○	Number of connected zone units (excluding outdoor and BS units)	0 ~ 63 units	Lower 6 digits
No 8	○ ● ● ○ ● ● ●	Number of outdoor units	0 ~ 63 units	Lower 6 digits
No 9	○ ● ● ○ ● ● ○	Number of BS units	0 ~ 128 units	Lower 4 digits, upper
No 10	○ ● ● ○ ● ○ ●	Number of BS units	0 ~ 128 units	Lower 4 digits, lower
No 11	○ ● ● ○ ● ○ ○	Number of zone units (excluding outdoor and BS units)	0 ~ 63 units	Lower 6 digits
No 12	○ ● ● ○ ○ ● ●	Number of terminal blocks	0 ~ 128 units	Lower 4 digits, upper
No 13	○ ● ● ○ ○ ● ○	Number of terminal blocks	0 ~ 128 units	Lower 4 digits, lower
No 14	○ ● ● ○ ○ ○ ●	Not used		
No 15	○ ● ● ○ ○ ○ ○	Not used		
No 16	○ ● ○ ● ● ● ●	Not used		

## 5 Sequential Start

- Separates path timing of commercial power supply compressors by 3 seconds each in order to prevent overcurrent when several compressors are to be started at the same time.
- Improved wiring system enables sequential start of up to 5 function units and 10 outdoor units.

Все каталоги и инструкции здесь: <https://splitsystema48.ru/instrukcii-po-ekspluatacii-kondicionerov.html>

own below.

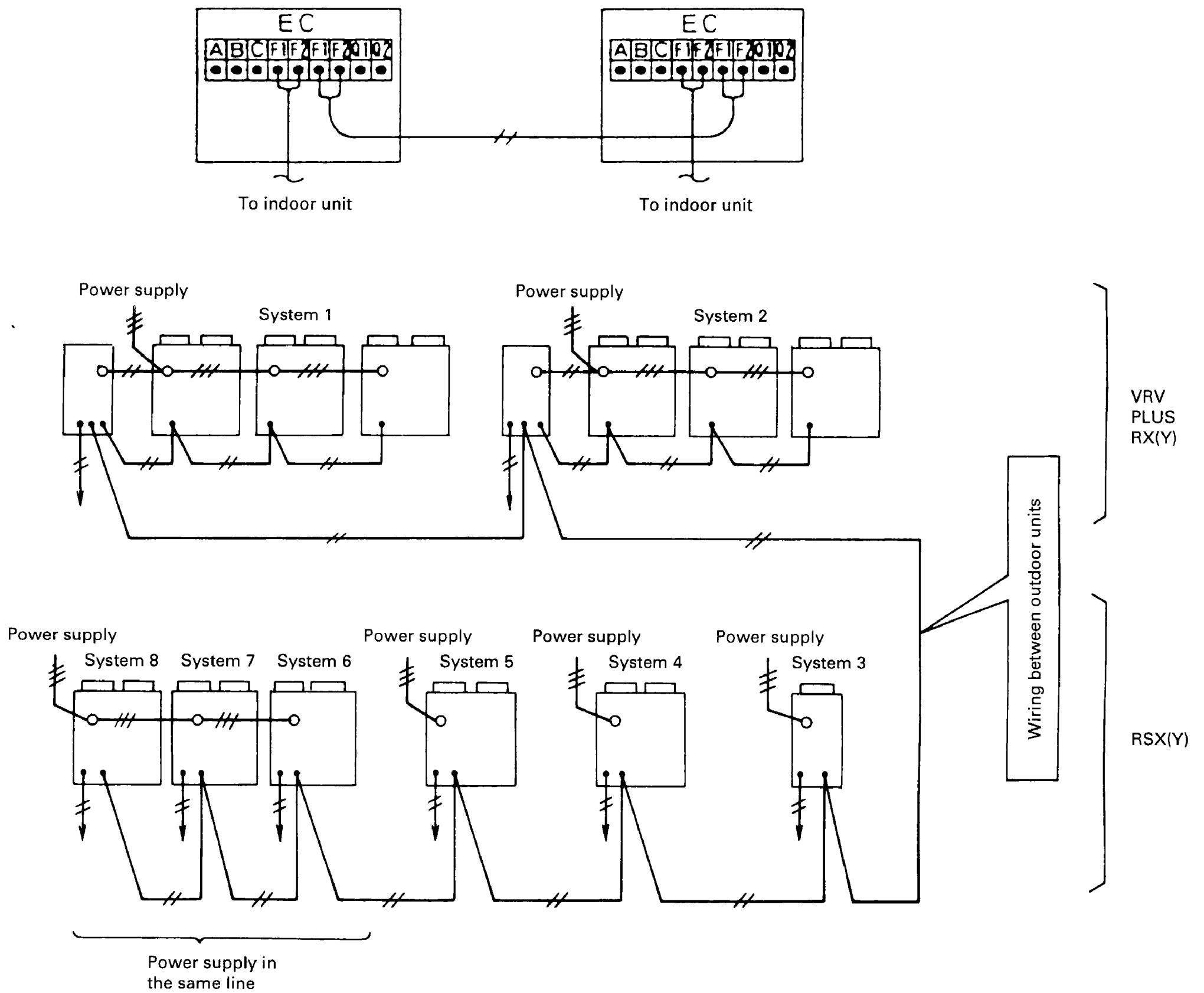

## 6 External Control Adaptor for Outdoor Units (DTA104A61-DTA104A62)

<Objective/use>

By adding an adaptor for outside control of outdoor units to BS units or indoor units connected in a DIII-NET, you can simultaneously select cool/heat mode for several outdoor units in the system, and it enables demand control and low

Все каталоги и инструкции здесь: <https://splitsystema48.ru/instrukcii-po-ekspluatacii-kondicionerov.html>

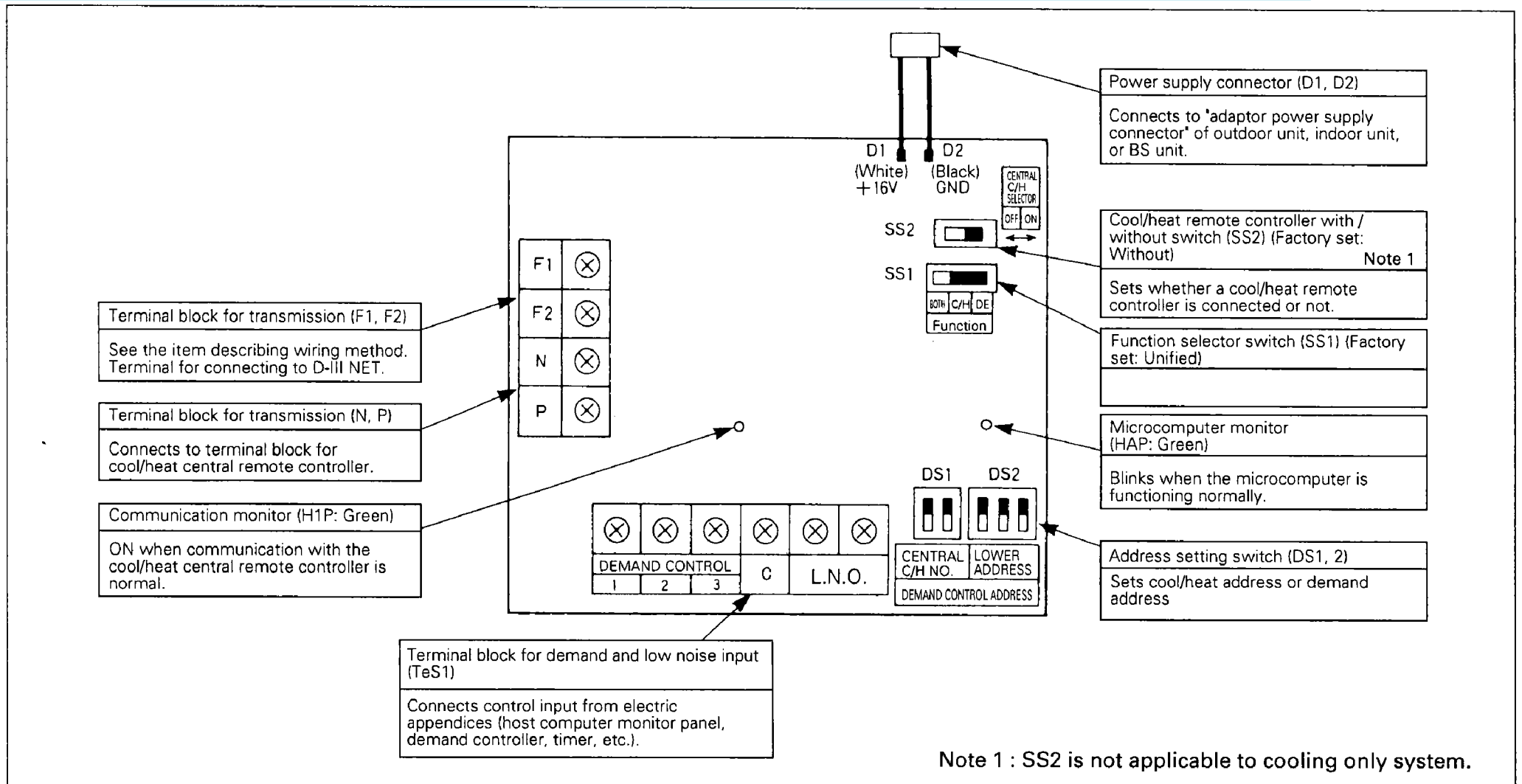

### (1) Cool/heat mode unified selection (For detailed example of wiring, see the page describing cool/heat mode control.)

<System outline>

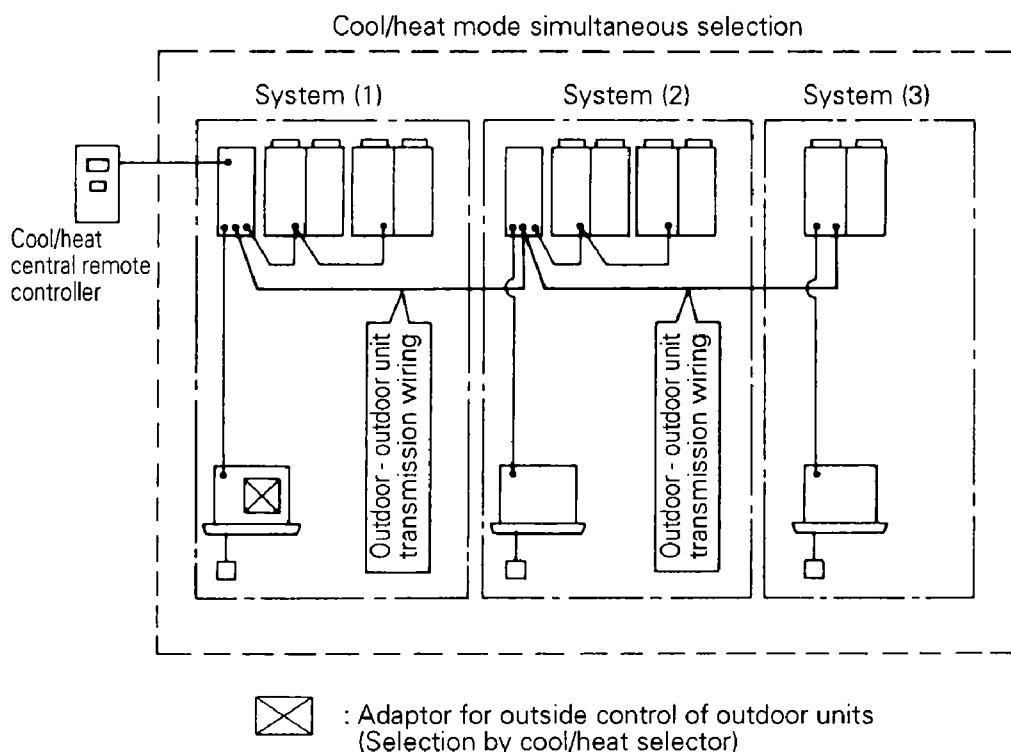

<Settings of switches on the PC board adaptor>

- SS1 C / H ("BOTH" is selected when demand control is carried out at the same time.)
- SS2 OFF
- DS1-2 Set the same address as the cool/heat mode address of the function unit.

<NOTE> ... For PLUS series.

- Set the SS1 cool/heat selector switch on the function unit to "outdoor." You must also set cool/heat selector "master" or "slave" by pushbutton switch.

## (2) Demand / low noise control

Connecting control input to the adaptor for outside control of outdoor units enables demand and low noise control.

### ■ Demand control (figures indicate demand rate)

When short circuit between (1) and (C): Approx. 70% as a guideline

When short circuit between (2) and (C): Approx. 40%

When short circuit between (3) and (C): Forced fan operation

<System outline>

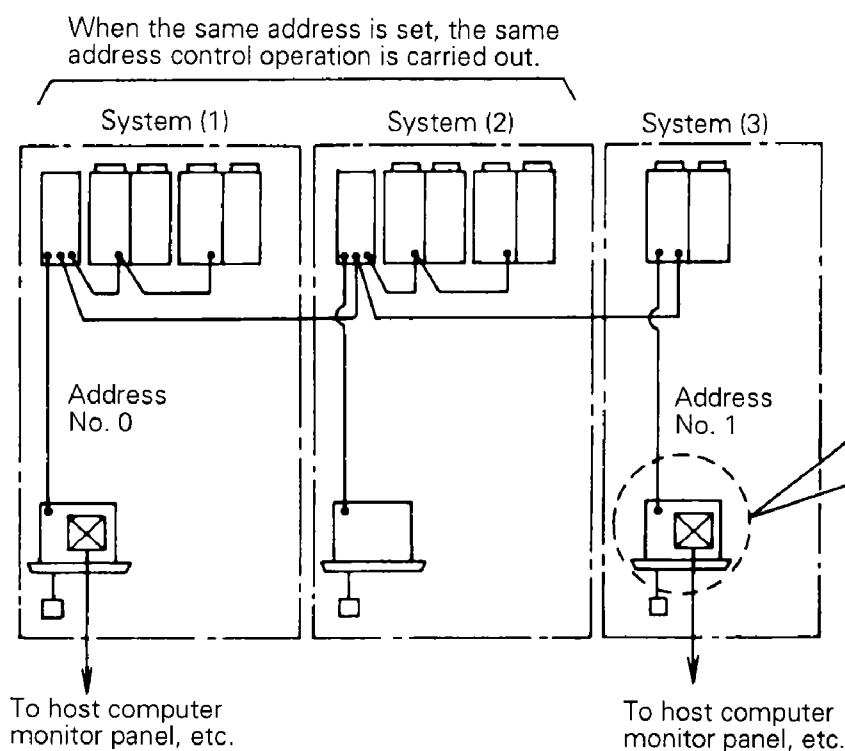

### ■ Low noise control (Outdoor unit)

Running noise can be reduced by 2~ 3dB by controlling capacity of outdoor unit.

Все каталоги и инструкции здесь: <https://splitsystema48.ru/instrukcii-po-ekspluatacii-kondicionerov.html>

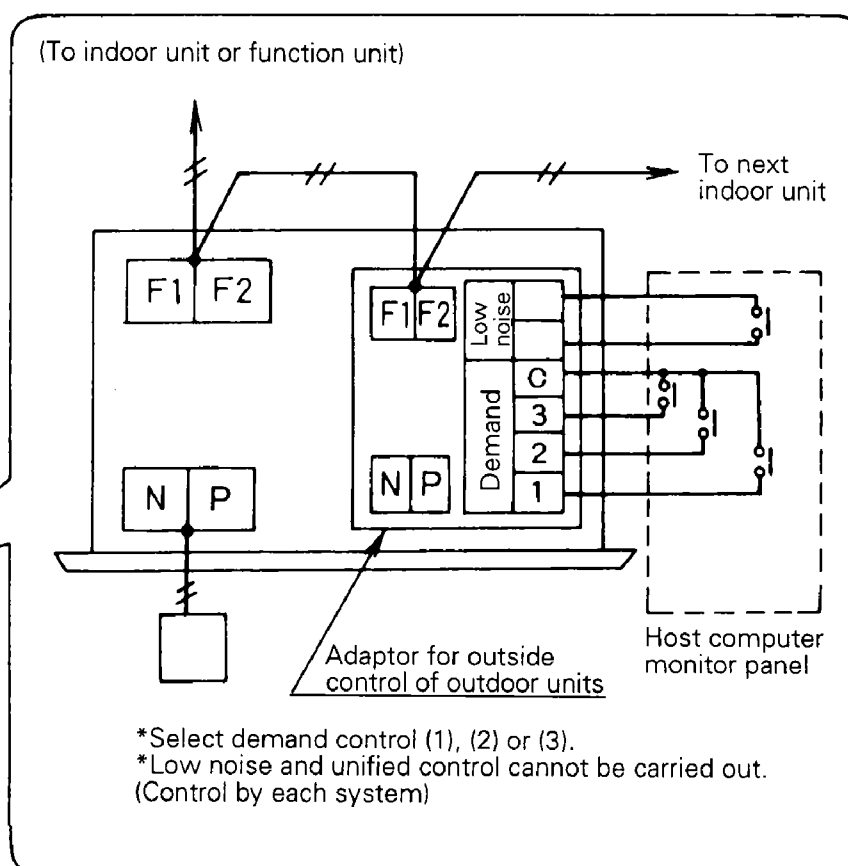

### 【Common】

#### <Address setting (DS1 / DS2)>

Decide the address for each control unit from 0~9 and set.

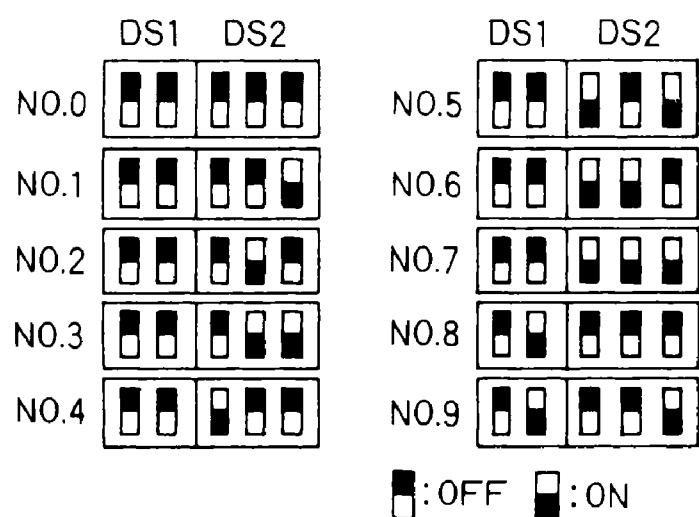

### NOTES

- Setting is within 8 groups when using a cool/heat central remote controller. Set from No. 0~No. 7.
- Be sure to make the address No. of the PC board adaptor described above match the address No. of function unit or outdoor unit (BS unit if using cool/heat simultaneous selection type).  
(For detailed settings, see the installation manual.)

#### <Control input specifications>

##### ■ Input signal

Constant contact a

Input current is approx. 12 - 24 VDC, 10 mA per contact.

Use a micro-current contact for the relay contact.  
(Max. 12 VDC, 1 mA)

##### ■ Outside wiring specifications

Recommended electric wiring: Sheathed vinyl cord or cable 0.75~1.25 mm<sup>2</sup> (double core)

Wiring length: Max. 150 m

Run separate from power line in order to prevent malfunction.

## 7 Cool/Heat Mode selection (※ Except for cooling only system)

The VRV PLUS Series offers the following four cool/heat mode selections.

- (1) Setting of cool/heat by individual outdoor unit system by indoor unit remote controller
- (2) Setting of cool/heat by individual outdoor unit system by cool/heat selector

Все каталоги и инструкции здесь: <https://splitsystema48.ru/instrukcii-po-ekspluatacii-kondicionerov.html>

indoor unit

- (4) Setting of cool/heat by outdoor unit system group in accordance with group master outdoor unit by cool/heat selector

Each of these setting methods is explained in detail below.

(For (3) and (4), be sure to perform power supply reset after changing settings.)

### (1) Setting of cool/heat by individual outdoor unit system by indoor unit remote controller

- Doesn't matter whether or not there is outdoor - outdoor unit wiring.
- Set SS1 of the outdoor unit PCB to "IN / D UNIT" (factory set).
- In setting mode 1, set cool/heat selection to "IND" (factory set).

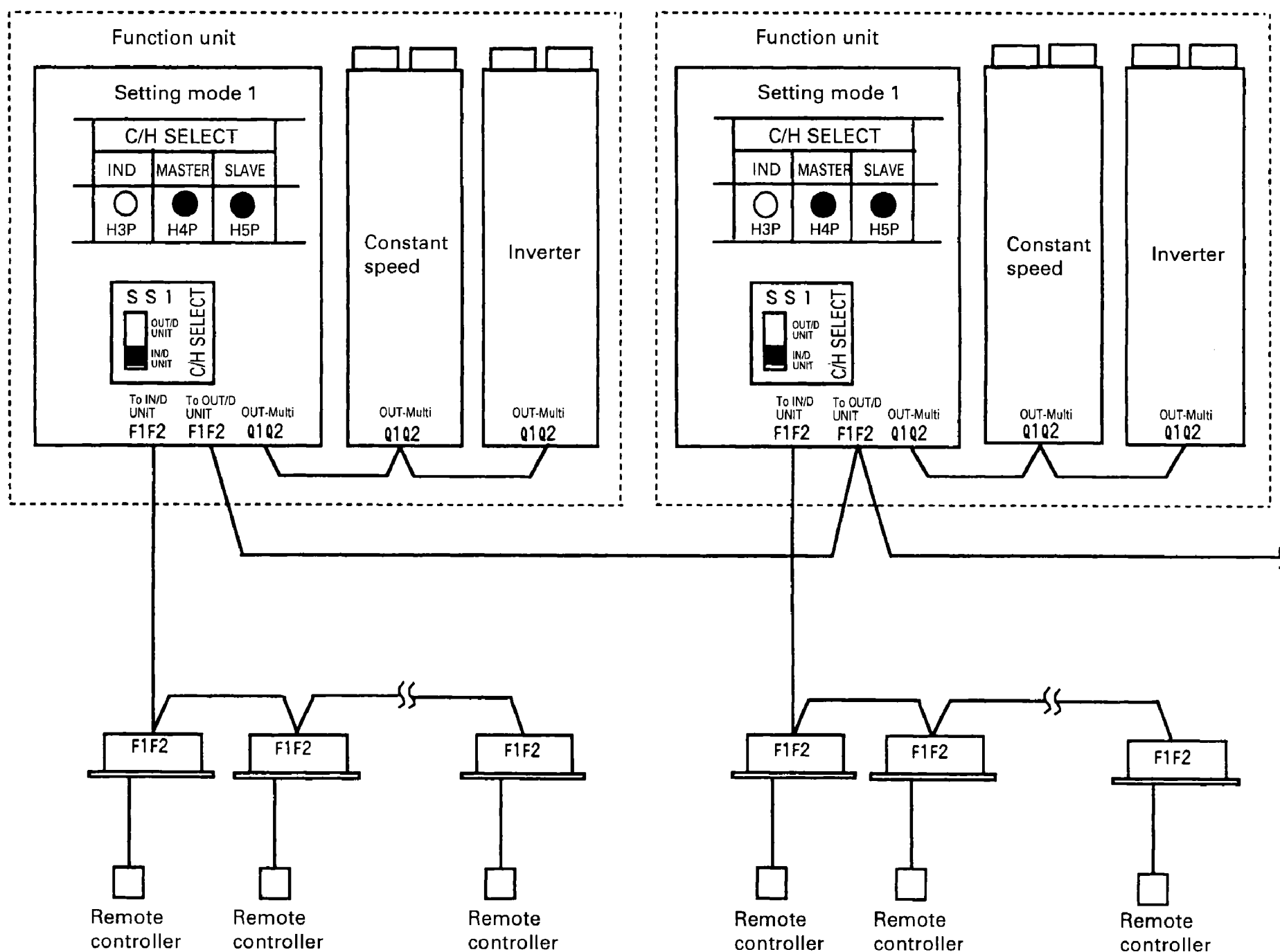

One of the remote controllers is given cool/heat selection permission.

One of the remote controllers is given cool/heat selection permission.

## (2) Setting of cool/heat by individual outdoor unit system by cool/heat selector

- Doesn't matter whether or not there is outdoor - outdoor unit wiring.
- Set SS1 of the outdoor unit PC board to "OUT / D UNIT".
- In setting mode 1, set cool/heat selection to "IND" (factory set).

Все каталоги и инструкции здесь: <https://splitsystema48.ru/instrukcii-po-ekspluatacii-kondicionerov.html>

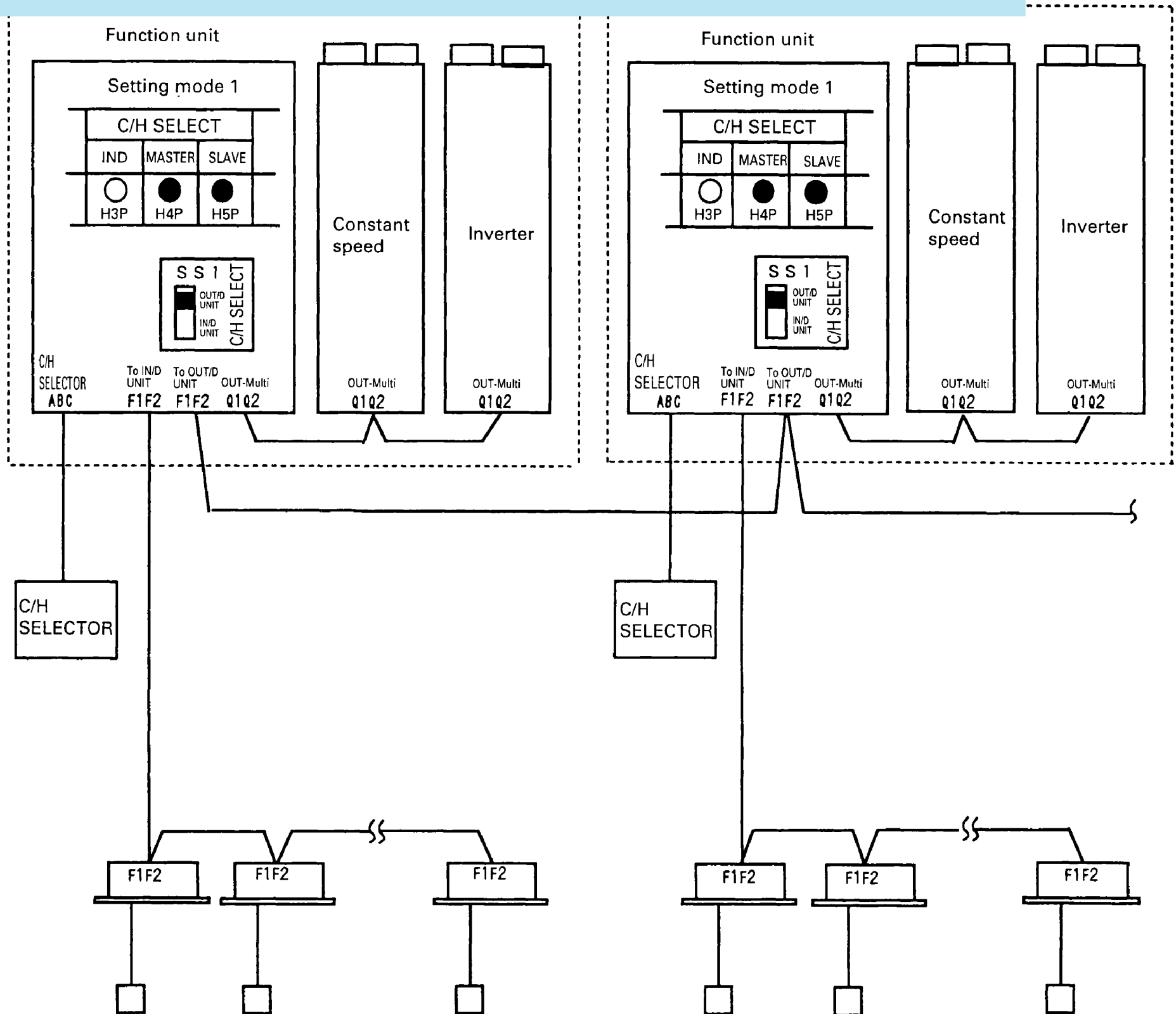



### (3) Setting of cool/heat by outdoor unit system group in accordance with group master outdoor unit by indoor unit remote controller

- Install the External control adaptor for outdoor unit on either the outdoor - outdoor, indoor - outdoor, or indoor - indoor transmission line.
- Set SS1 of the outdoor unit PCB to "IN / D UNIT" (factory set).
- In setting mode 1, set the outdoor unit you want to give cool/heat selection permission to as the group master, and

Все каталоги и инструкции здесь: <https://splitsystema48.ru/instrukcii-po-ekspluatacii-kondicionerov.html>

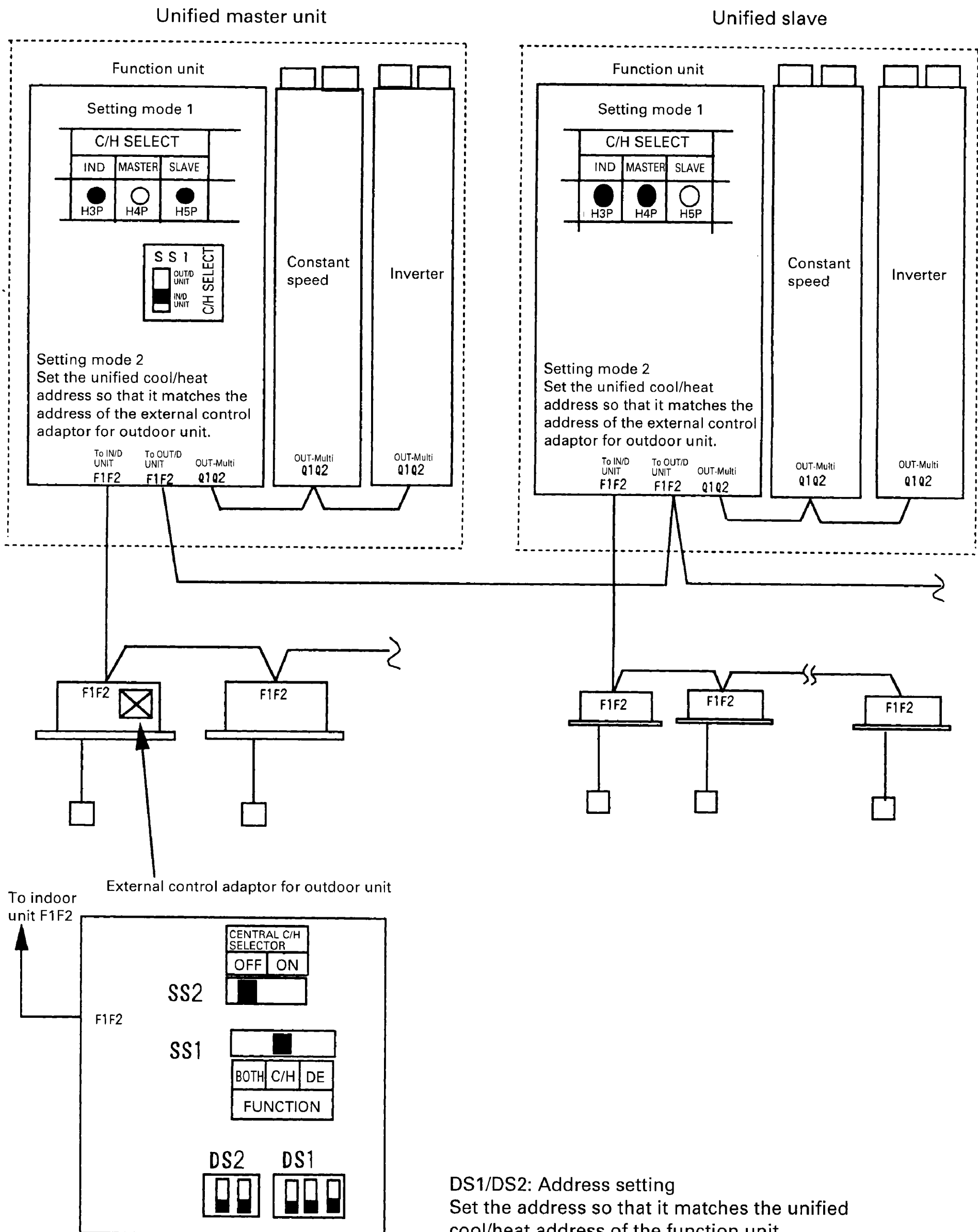

**(4) Setting of cool/heat by outdoor unit system group in accordance with group master outdoor unit by cool/heat selector**

- In addition to (3), change the following:
- Install a cool/heat selector to the group master outdoor unit.
- Set SS1 of the group master outdoor unit's PCB to "OUT / D UNIT."

Все каталоги и инструкции здесь: <https://splitsystema48.ru/instrukcii-po-ekspluatacii-kondicionerov.html>

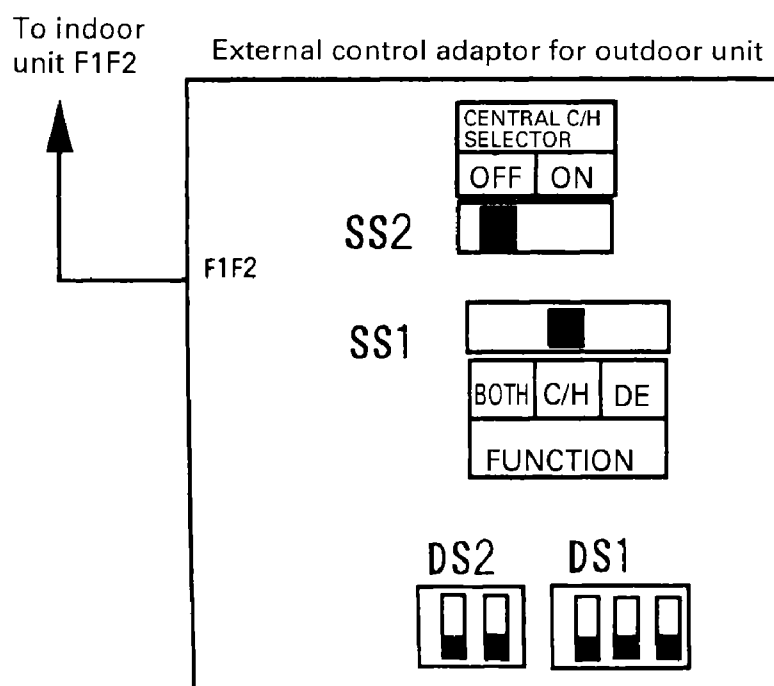
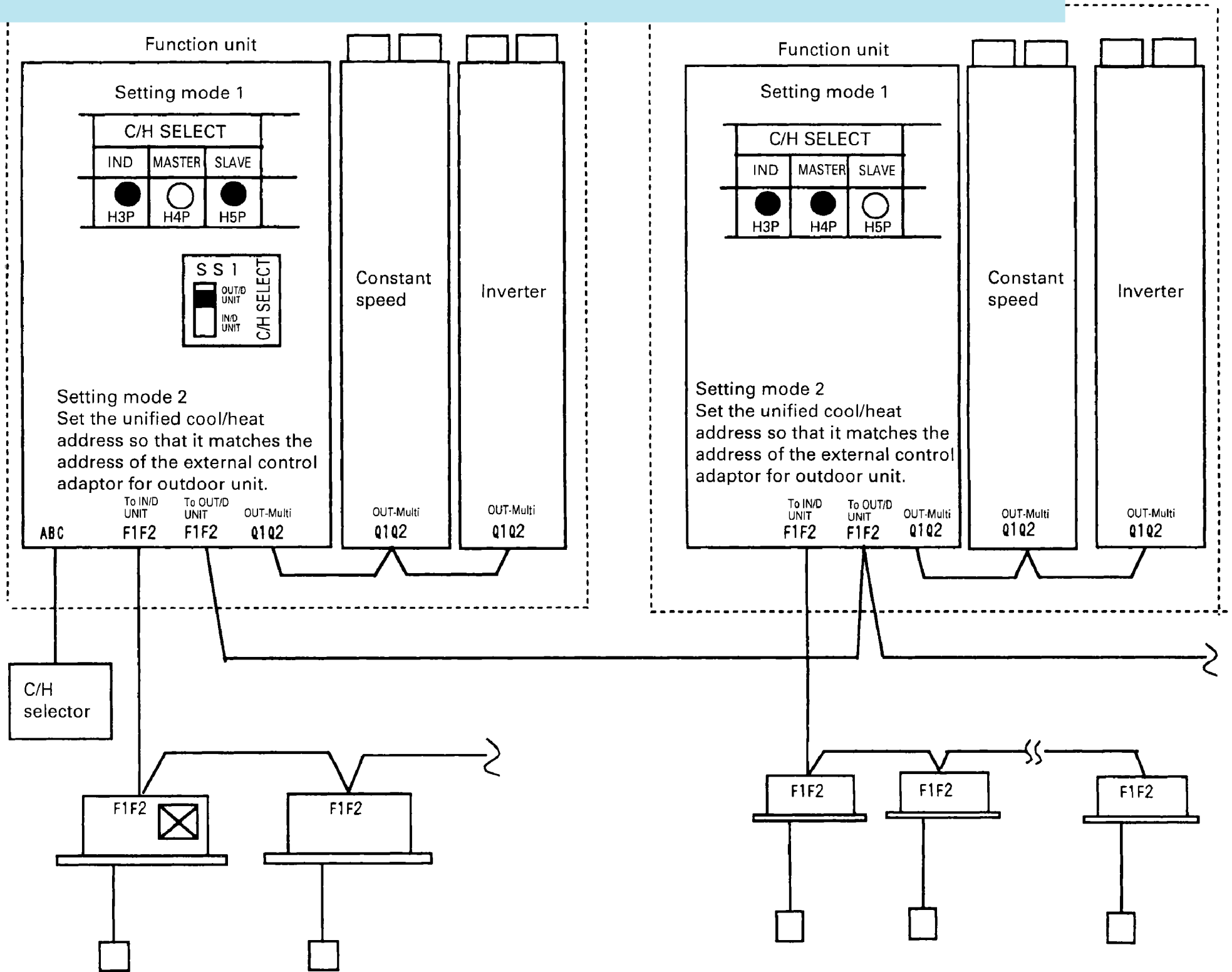

DS1/DS2: Address setting  
Set the address so that it matches the unified cool/heat address of the function unit.

## 8 Low Noise Operation

By connecting the external contact input to the low noise input of the external control adaptor for outdoor unit (optional), you can save power and lower operating noise by 2 -3 dB.

Все каталоги и инструкции здесь: <https://splitsystema48.ru/instrukcii-po-ekspluatacii-kondicionerov.html>

- Setting mode 2 : Match low noise operation and demand control address with address of external control adaptor for outdoor unit.

### 2. Outdoor unit external control adaptor setting

- Function switch (SS1)  
Set to "BOTH" or "DE."
- Address setting switches (DS1, DS2)  
Match with outdoor unit low noise operation and demand control address.

### 3. Short-circuit the outdoor unit external control adaptor's low noise input.

[Low noise control system example]

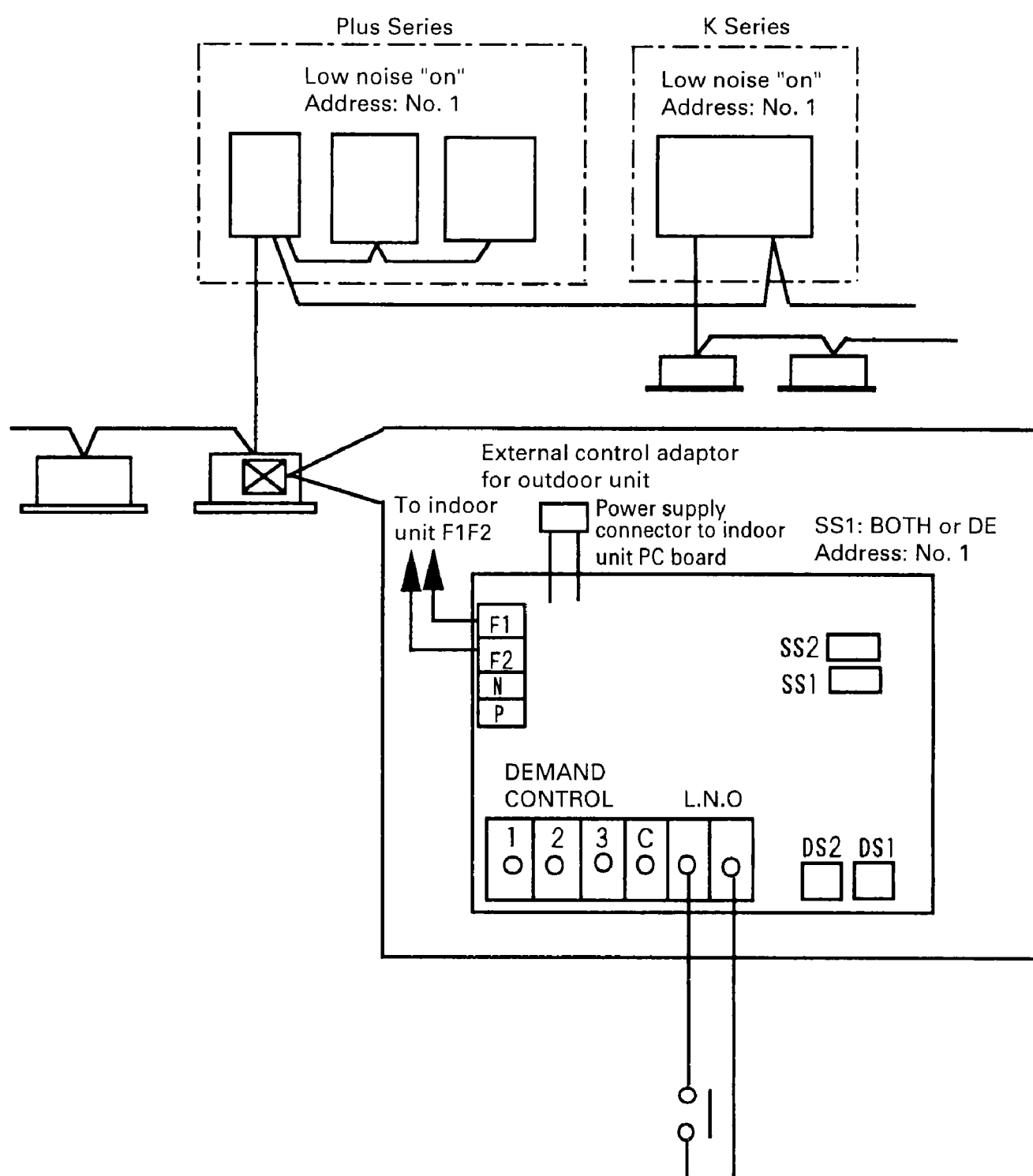

## 9 Demand Control

By connecting the external contact input to the Demand control input of the external control adaptor for outdoor unit (option), you can save power with limit of compressor frequency.

Все каталоги и инструкции здесь: <https://splitsystema48.ru/instrukcii-po-ekspluatacii-kondicionerov.html>

(3) Demand 3: Forced OFF by thermostat

### 1. Outdoor unit field setting

- Setting mode 1 : Set low noise operation to "ON."
- Setting mode 2 : Match low noise operation and demand control address with address of external control adaptor for outdoor unit.

### 2. Outdoor unit external control adaptor setting

- Function switch (SS1)  
Set to "BOTH" or "DE."
- Address setting switches (DS1, DS2)  
Match with outdoor unit low noise operation and demand control address.

### 3. Select demand input and short circuit it.

- ① Demand 1 : Short circuit between 1 and C.
- ② Demand 2 : Short circuit between 2 and C.
- ③ Demand 3 : Short circuit between 3 and C.

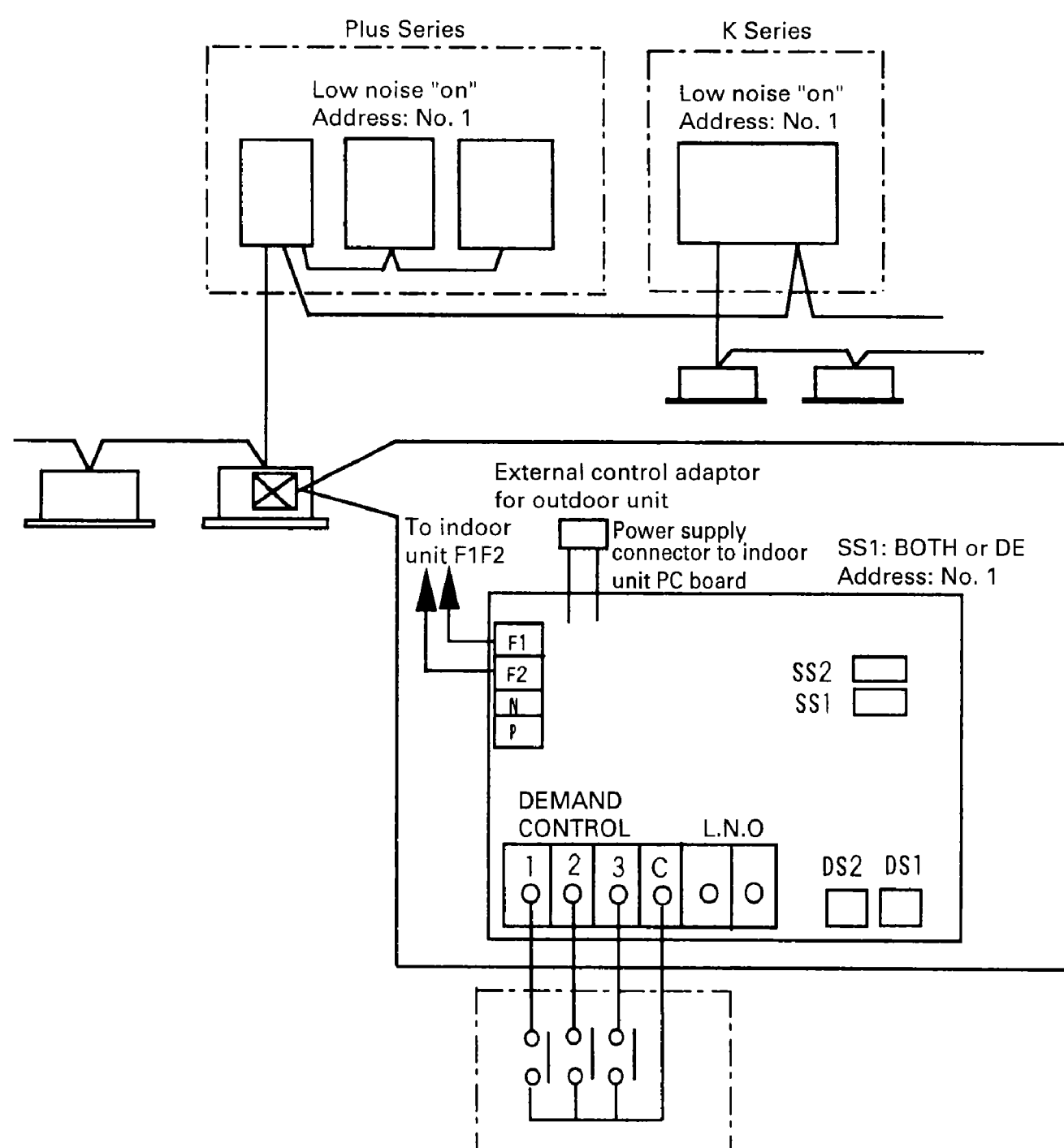

## 10 Wiring Check Operation

If within 12 hours of stopping cooling or heating, be sure to run all indoor units in the system you want to check in the fan mode for about 60 minutes in order to prevent mis-detection.

Все каталоги и инструкции здесь: <https://splitsystema48.ru/instrukcii-po-ekspluatacii-kondicionerov.html>

1. In the monitor mode, check the number of connected indoor units. (See monitor mode.)
2. Push and hold the WIRING CHECK button (BS4) for 5 seconds to perform wiring check operation. While running, TEST (H2P) lights and goes off when finished. If TEST (H2P) flickers (wiring check operation failure), push and hold the RESET button (BS5) for 5 seconds, and then repeat the procedure from the beginning.
3. About 1 minute after you finish running the system, once again check the number of connected indoor units in the monitor mode and make sure the number agrees with the first time you checked. If not, it indicates that there is a wiring mistake. Fix the wiring of the indoor unit whose remote controller displays "UF" when its ON/OFF switch is turned ON.

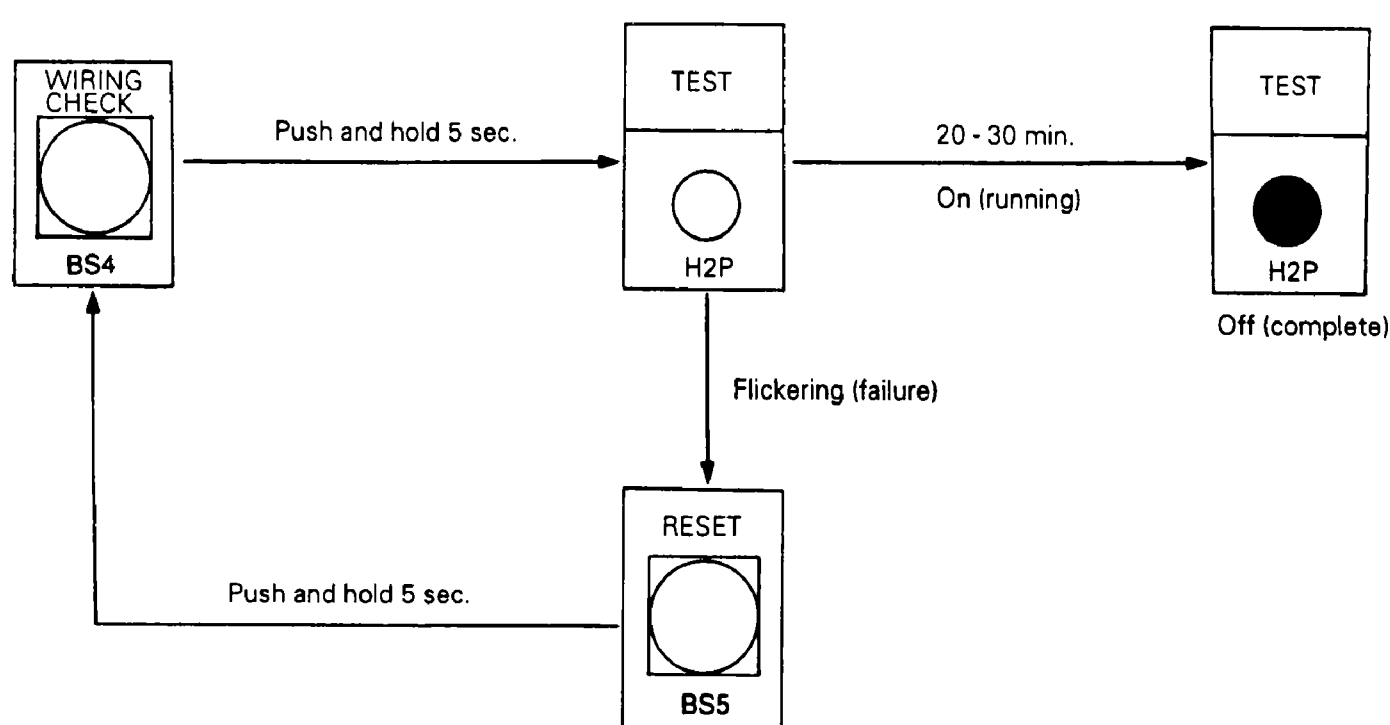

NOTE: Other settings are not accepted during wiring check operation.

# (Reference) Starting Control

## 1. Soft start

Starts inverter type by low operation frequency in order to prevent refrigerant pump down when the compressor starts for both cooling and heating.

Все каталоги и инструкции здесь:

<https://splitsystema48.ru/instrukcii-po-ekspluatacii-kondicionerov.html>

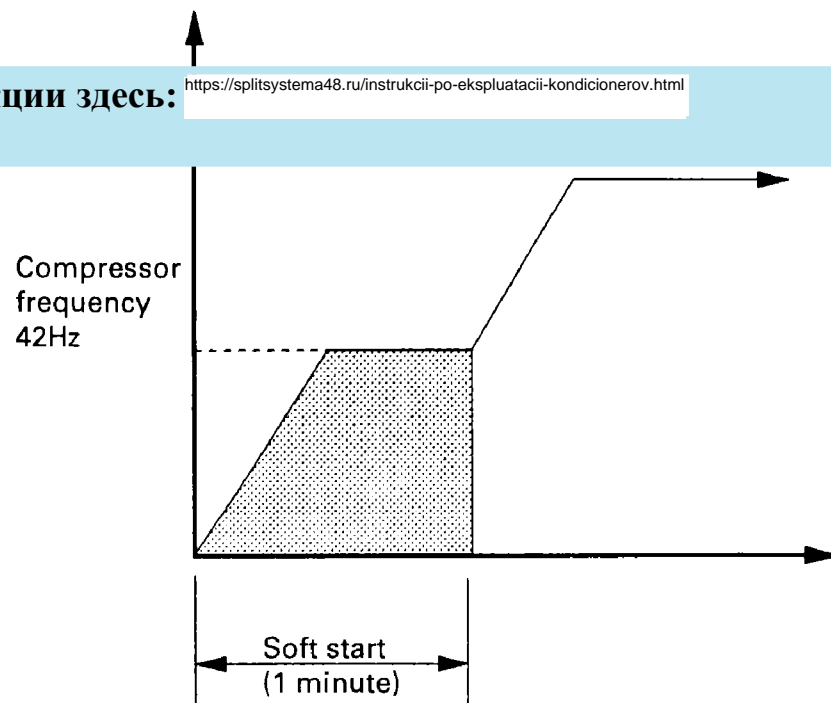

## 2. Cooling start following layup

When starting cooling operation under the following conditions, temporarily starts all outdoor units in order to discharge refrigerant from the low pressure line and accumulator when outdoor temperature is low.

- (1) If starting for first time after turning power on, or if outdoor temperature is 10°C or below.
- (2) If the compressor has been off for 24 hours or more, and the outdoor temperature is 0°C or below.

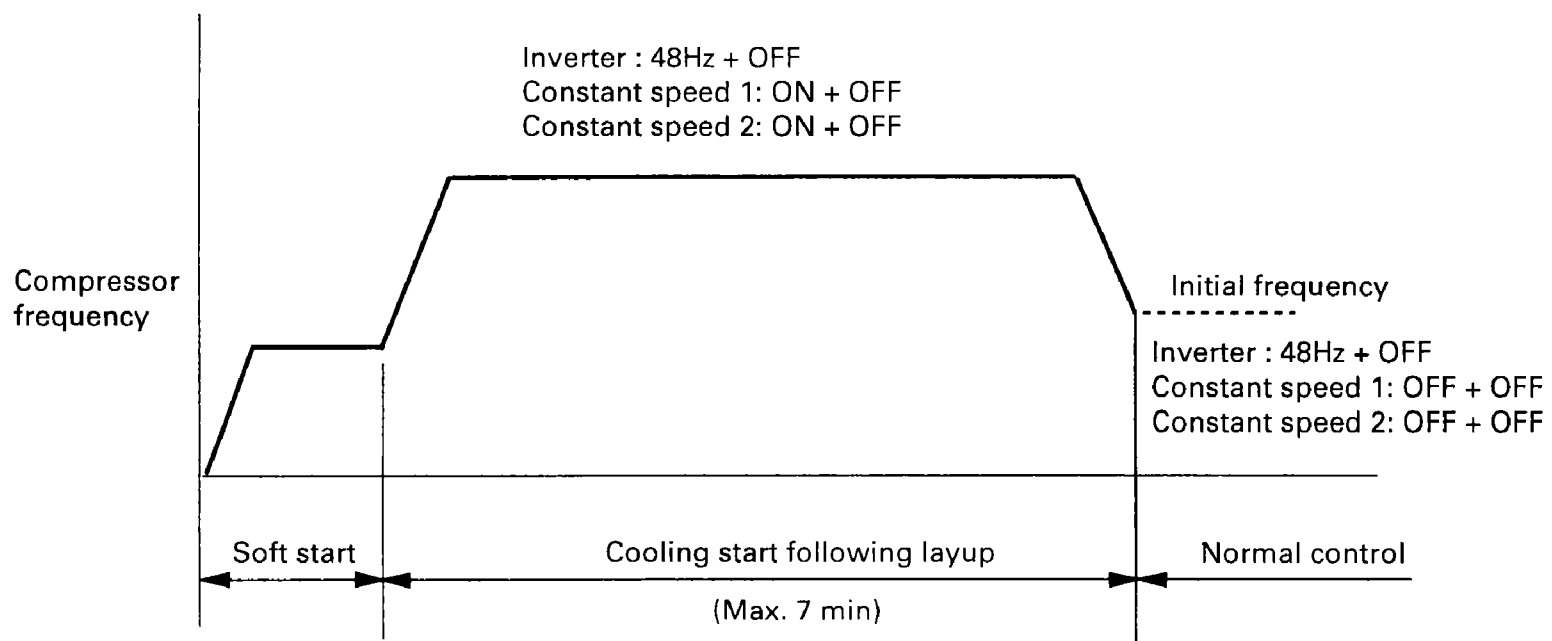

### Supplementary explanation

Inverter: 48Hz + OFF

- Indicates operating frequency of standard compressor.
- Indicates operating frequency of inverter compressor.

Constant speed 1: ON + OFF  
Constant speed 2: ON + OFF

- Indicates operating status of 2 standard compressors of constant speed type unit.
- ON + ON : Both compressors operating
- ON + OFF : 1 of the 2 compressors operating
- OFF + OFF : Both compressors off

### 3. Starting control when heating (※Except for cooling only system)

In addition to normal starting control, there are 3 types of starting control according to conditions when starting.

#### (1) Starting for first time after turning power on

Conditions when starting	Starting control
<p>Все каталоги и инструкции здесь: <a href="https://splitsystema48.ru/instrukcii-po-ekspluatacii-kondicionerov.html">https://splitsystema48.ru/instrukcii-po-ekspluatacii-kondicionerov.html</a></p>	
(2) Oil temperature of inverter type compressor is 15°C or more higher than the outdoor temperature.	Heating start following layup
(3) Discharge pipe temperature of inverter type compressor is 10°C or more higher than the outdoor temperature. (Outdoor temp. $\geq 0^\circ\text{C}$ )	
(4) Discharge pipe temperature of inverter type compressor is 10°C or higher. (Outdoor temp. $< 0^\circ\text{C}$ )	
(5) Other	Heating power on start

#### (2) Starting for second time and subsequent after turning power on

Conditions when starting	Starting control
(1) 3 hours has elapsed since compressor stopped running.	Heating start following layup
(2) Pump down operation was performed when the compressor stopped the previous time.	Heating pump down start
(3) Defrost, retry during oil return	
(4) Other	Normal start (Soft start only)

#### Heating start following layup

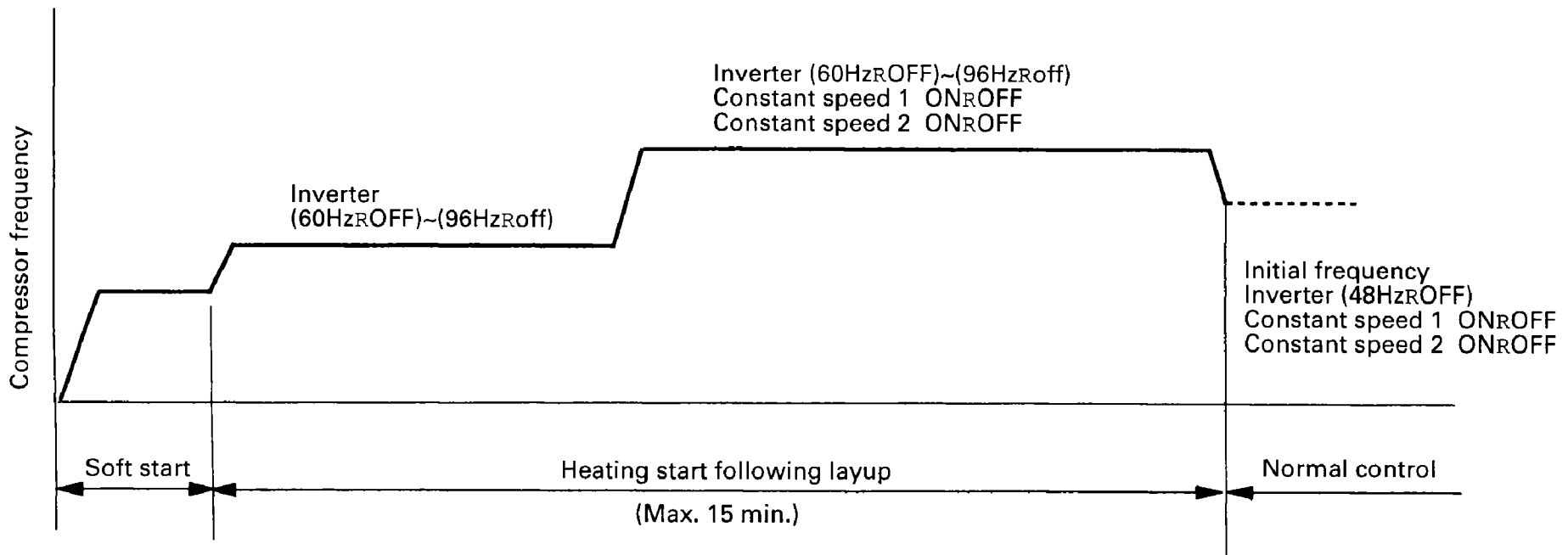

**Heating power on start**

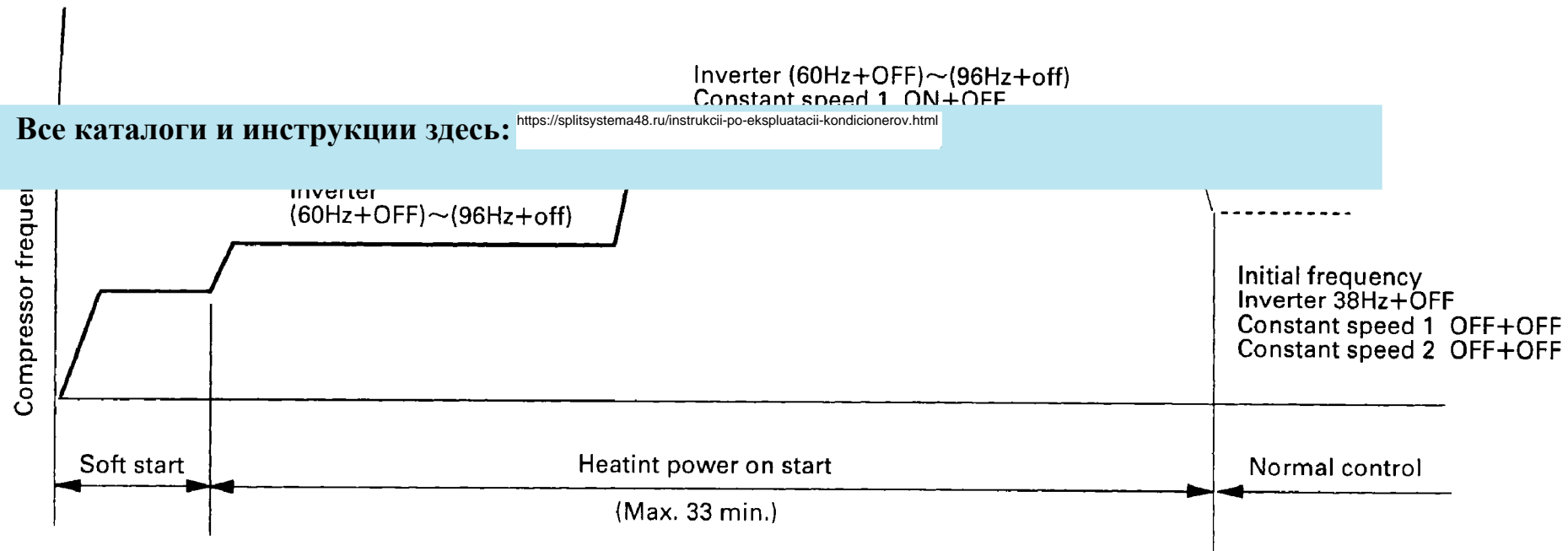

**Heating pump down start**

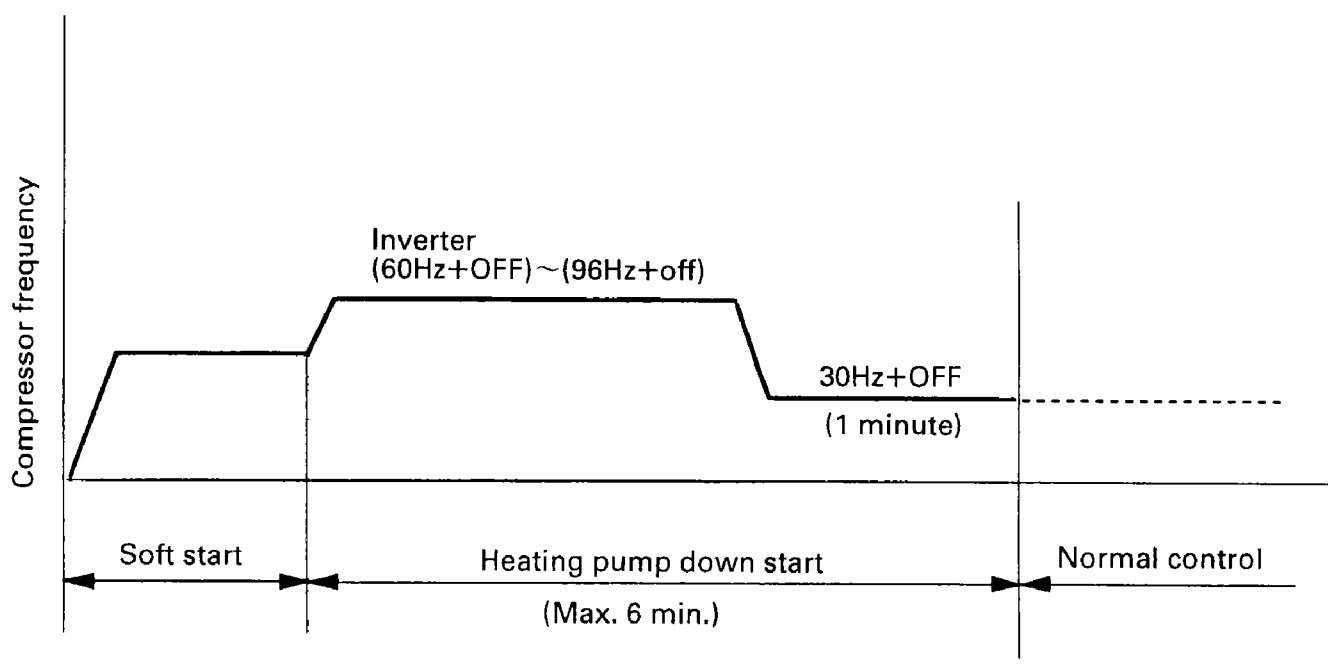



## 17. Installation Examples

The following are typical examples of PLUS Series installation.

Outdoor unit layout is one of the most important things. If improperly laid out, refrigerant pipes will cross each other making the work difficult. This also makes for a sloppy appearance.

We hope the following installation examples will help you to do a perfect job.

Все каталоги и инструкции здесь: <https://splitsystema48.ru/instrukcii-po-ekspluatacii-kondicionerov.html>

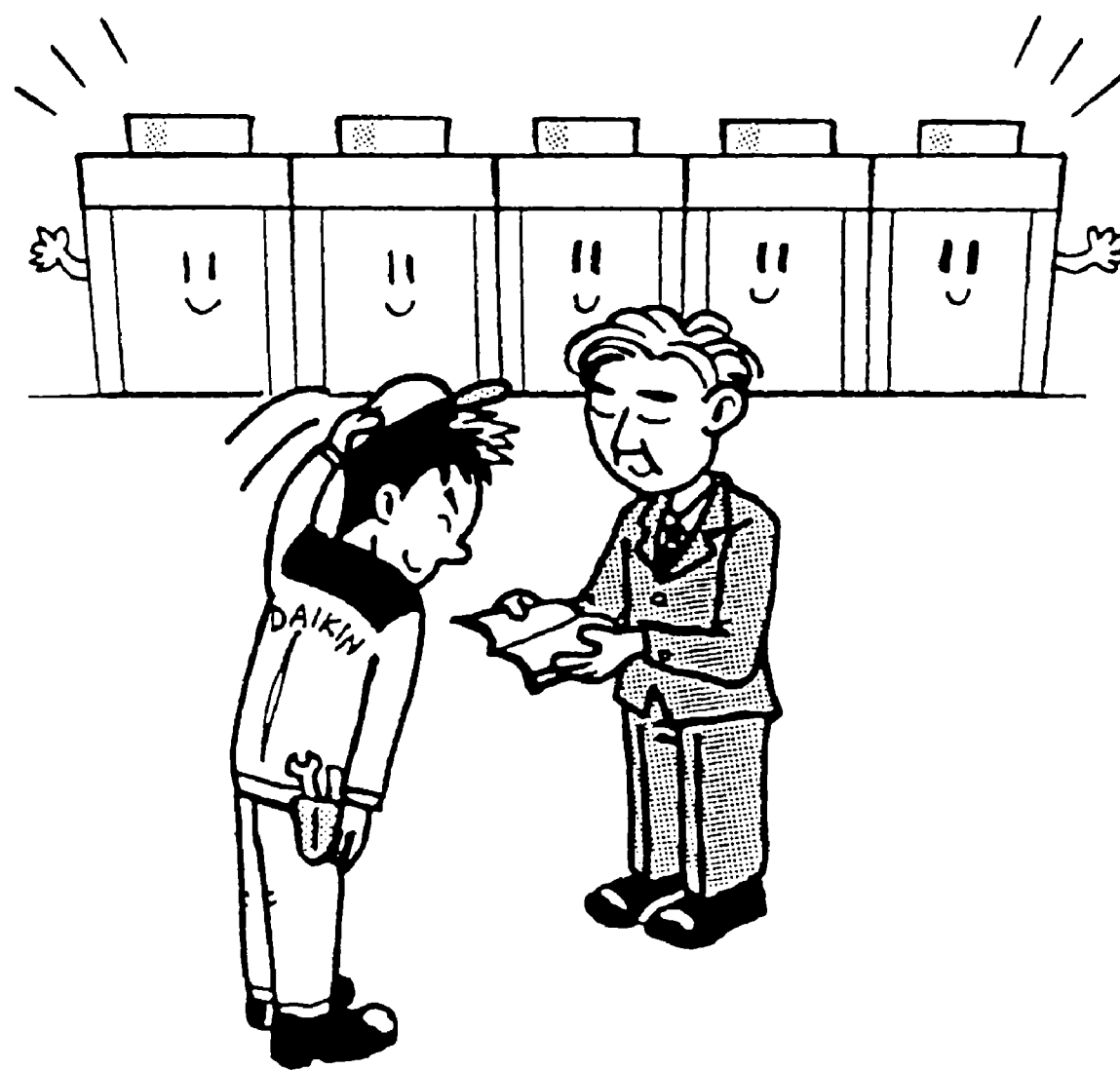

## Installation Example 1

There should be sufficient space in front of the outdoor unit.

Все каталоги и инструкции здесь: <https://splitsystema48.ru/instrukcii-po-ekspluatacii-kondicionerov.html>

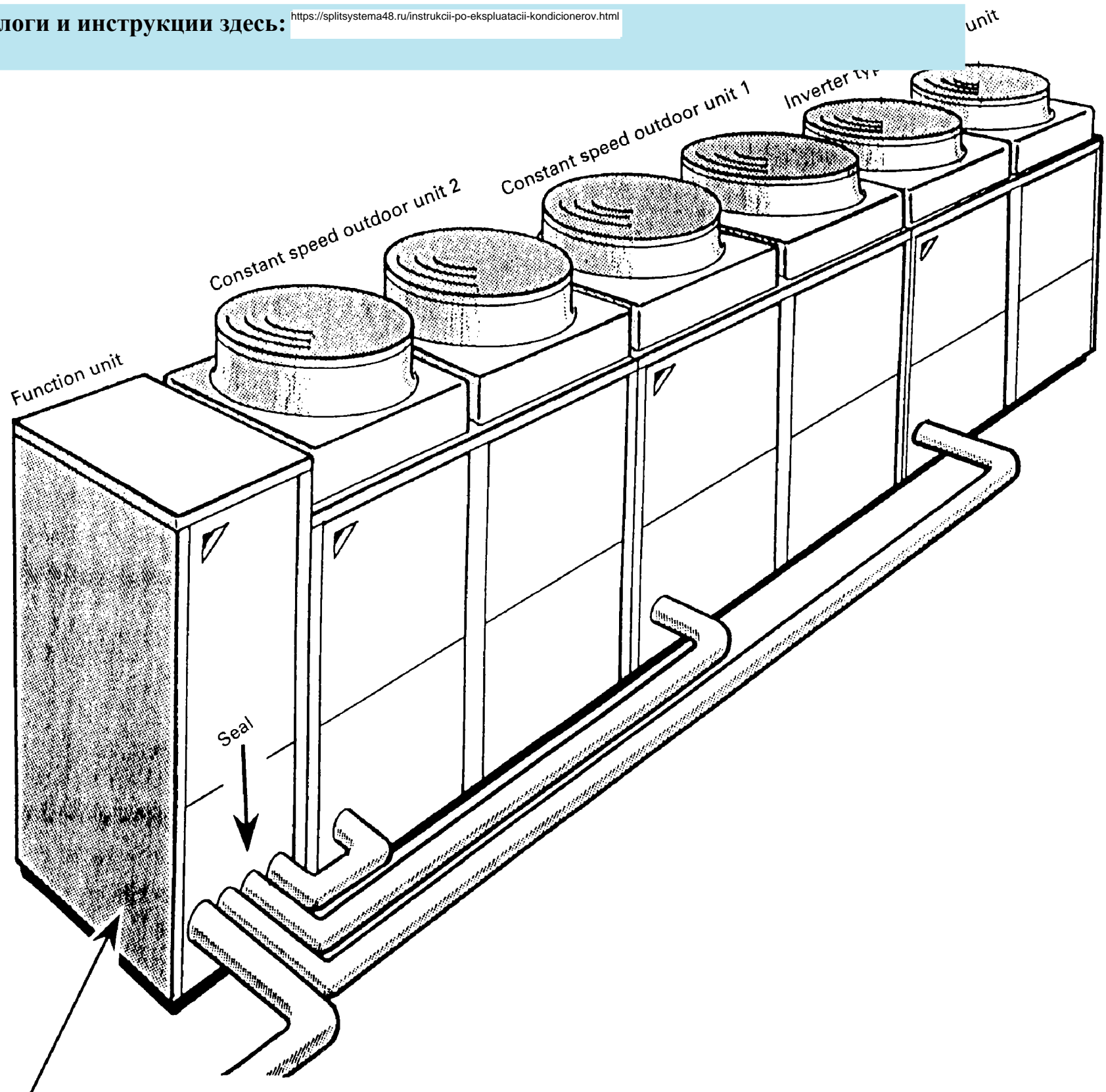

You can run piping between the function unit and indoor units by drilling a hole in left side panel of the function unit. (The hole must be drilled in the field.)

### Work points

- Work is carried out using the attached piping.
- Drill a hole for piping in the bottom panel of the function unit and seal it.

## Installation Example 2

Installation is carried out in the same manner as in installation example 1, except the piping is run internally between the constant speed outdoor unit and function unit by drilling a hole on the right side of the function unit.

Все каталоги и инструкции здесь: <https://splitsystema48.ru/instrukcii-po-ekspluatacii-kondicionerov.html>

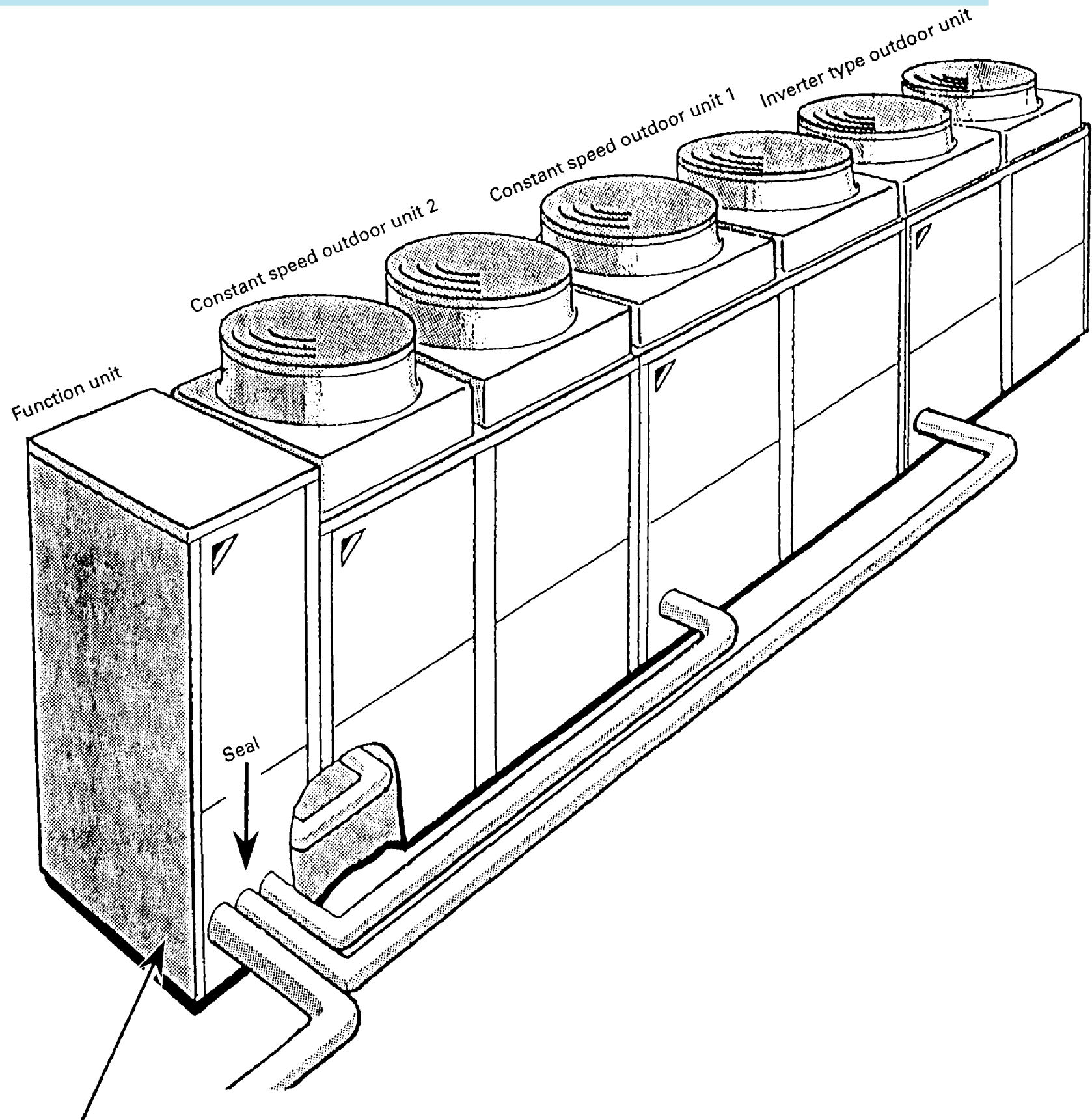

You can run piping between the function unit and indoor units by drilling a hole in left side panel of the function unit. (The hole must be drilled in the field.)

### Work points

- Drill holes on the right side and bottom panels of the function unit.

## Installation Example 3

You can run piping from the bottom of the outdoor unit if there is not enough space in the front.

Все каталоги и инструкции здесь: <https://splitsystema48.ru/instrukcii-po-ekspluatacii-kondicionerov.html>

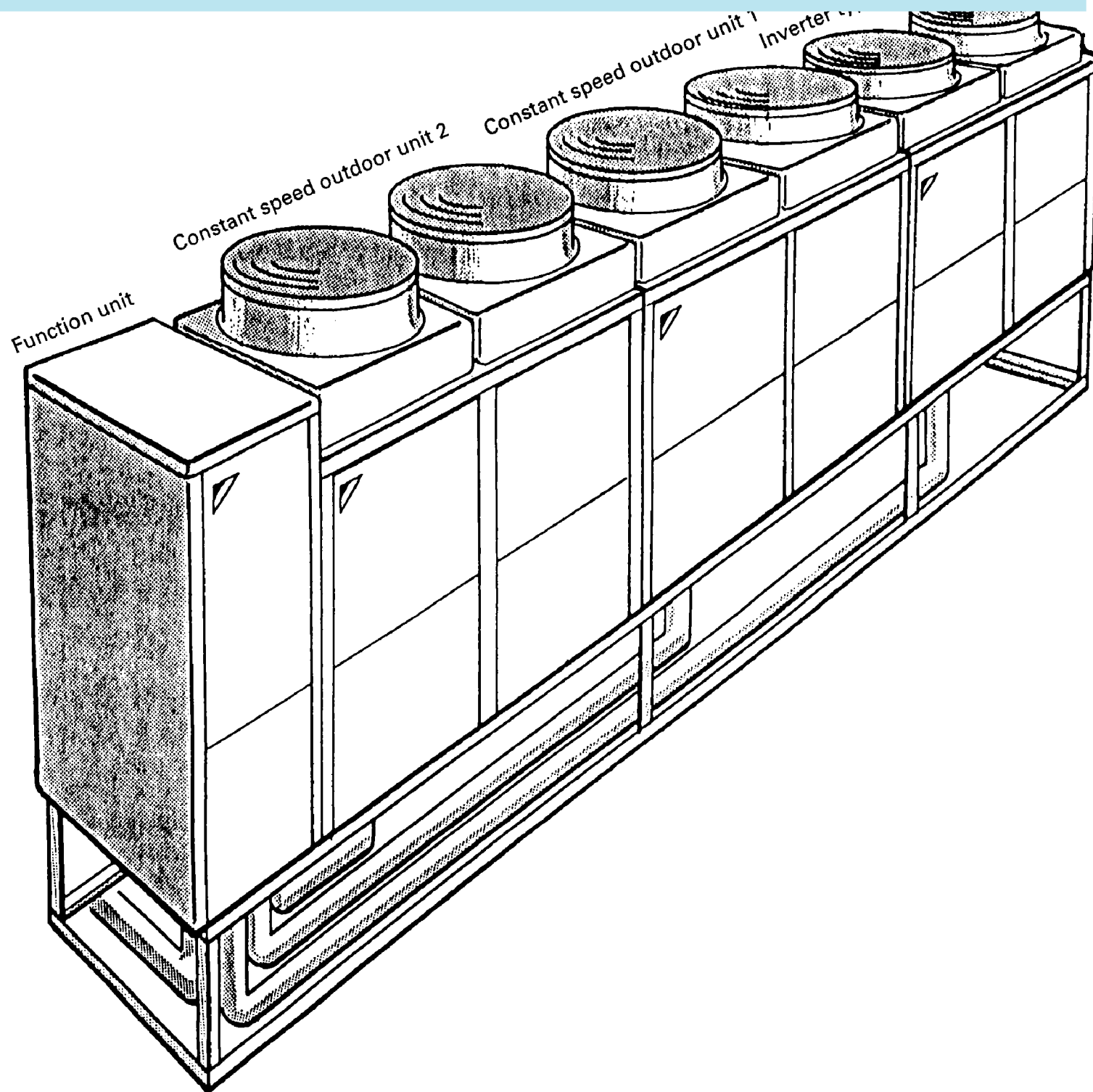

### Work points

- There is a hole for piping in the bottom of outdoor units.
- You can install piping in the field without using the attached piping. You can also modify some of the attached piping. Piping insulation work can be facilitated by providing about 300 - 400 mm of space below the outdoor unit when installing piping.
- Some commercially available vibration isolators may block the opening for piping in the bottom of the unit. (We therefore recommend you use DAIKIN genuine parts.)

## Installation Example 4

You can run a refrigerant piping duct from the function unit if many outdoor units are to be installed.

Все каталоги и инструкции здесь: <https://splitsystema48.ru/instrukcii-po-ekspluatacii-kondicionerov.html>

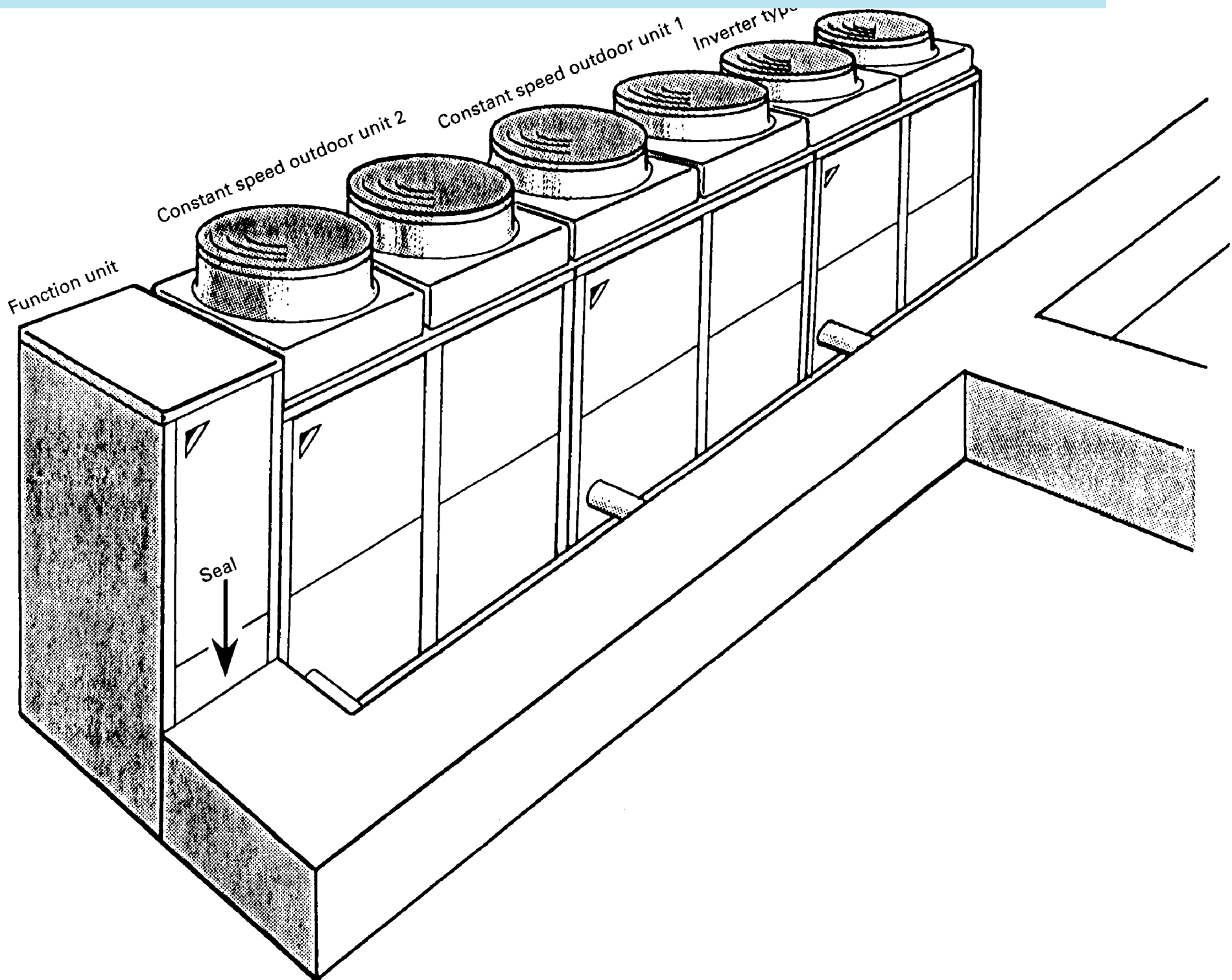

### Work points

- At least 500 mm of service space should be provided between outdoor units and the duct.
- You can connect the duct by removing or cutting the bottom panel of the function unit.
- Seal the duct after installing.

## Installation Example 5

Installing piping as shown below due to lack of space in front of outdoor units makes maintenance of constant speed type outdoor units difficult.

Все каталоги и инструкции здесь: <https://splitsystema48.ru/instrukcii-po-ekspluatacii-kondicionerov.html>

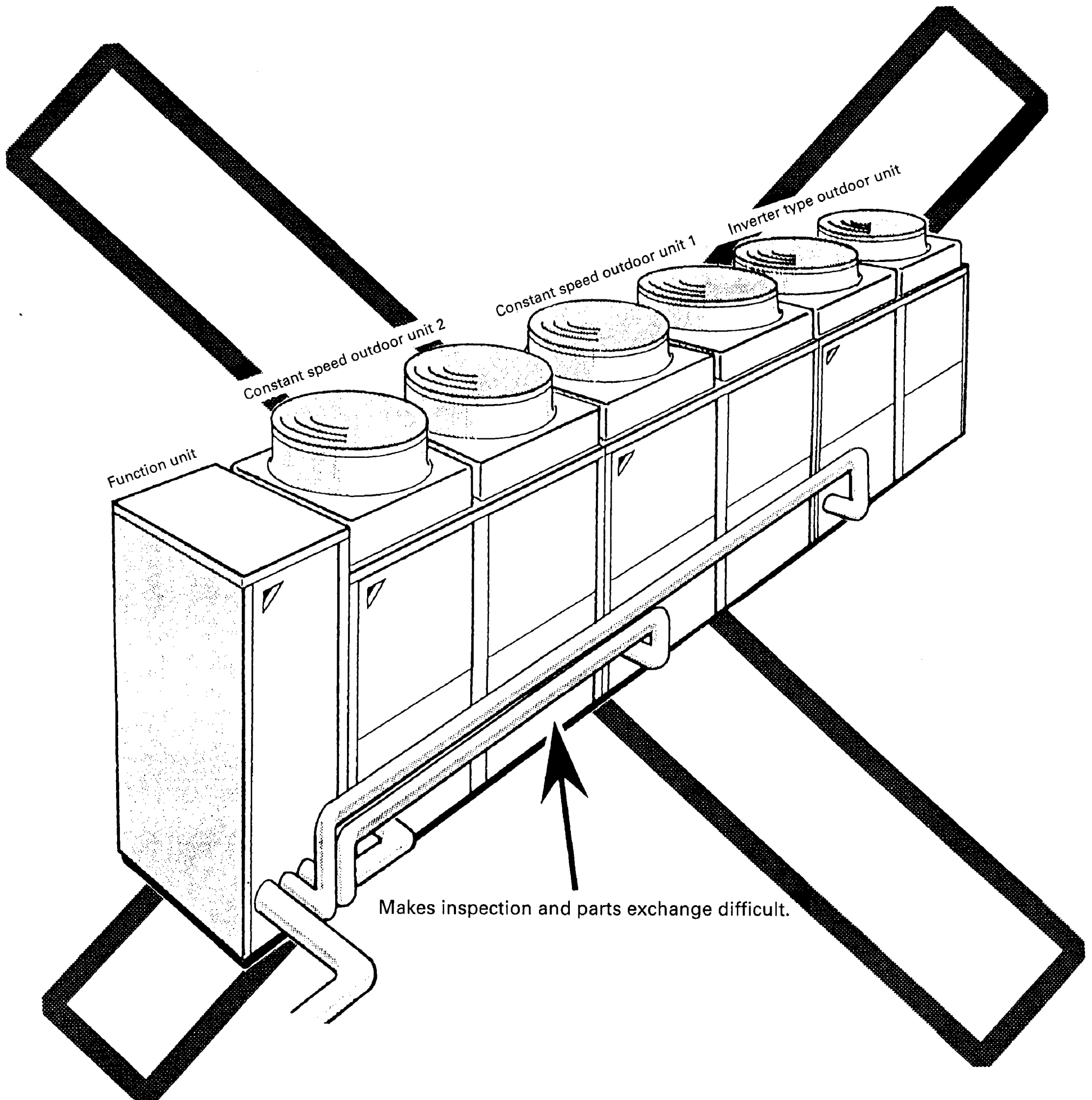

## Installation Example 6

Pipes will cross each other if outdoor units are improperly laid out.

Все каталоги и инструкции здесь: <https://splitsystema48.ru/instrukcii-po-ekspluatacii-kondicionerov.html>

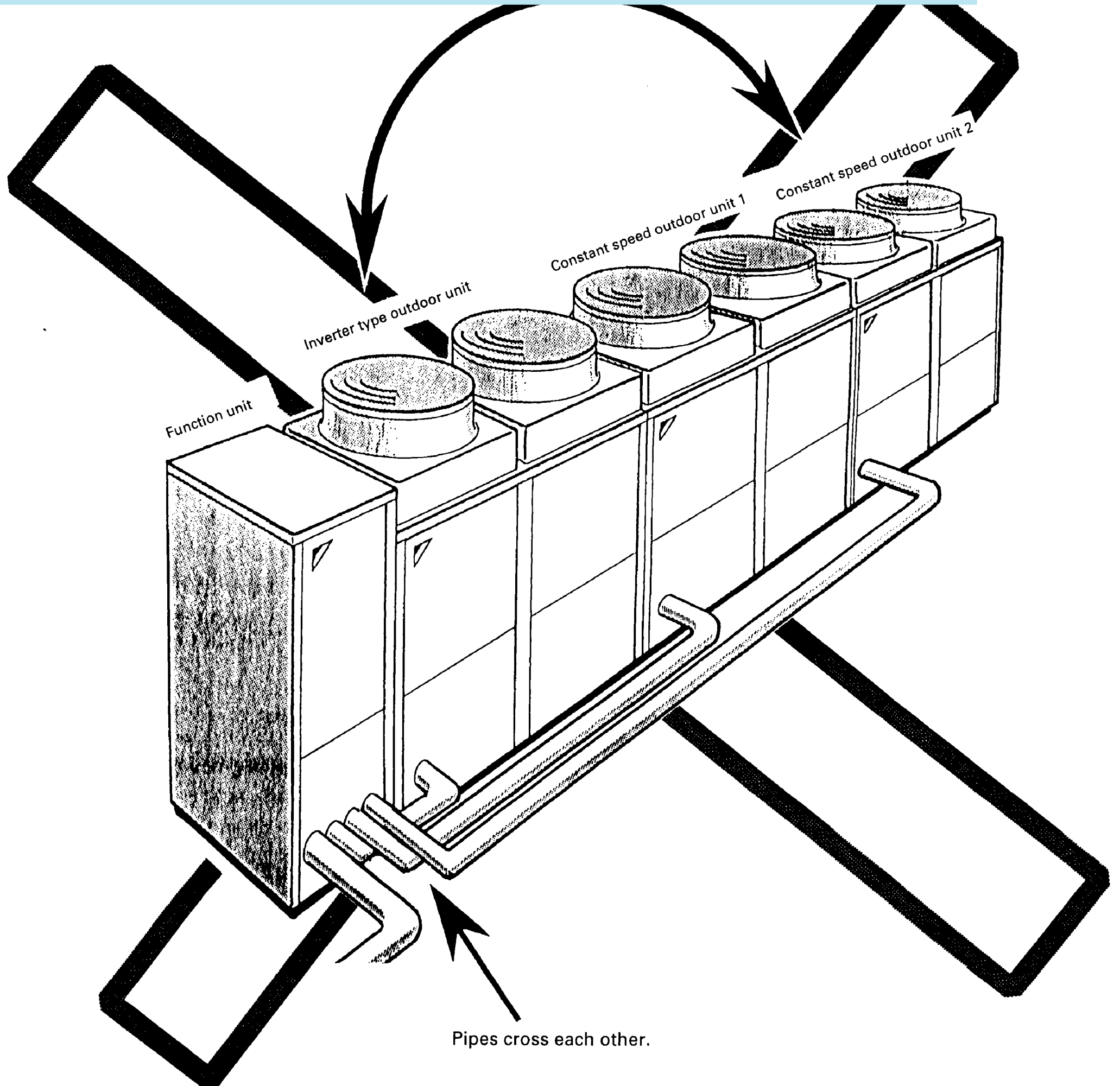

# Appendix

## 1. Selection of Vacuum Pump

### General

Refrigerant piping content volume of the Plus Series is larger than the VRV Inverter Series, and consequently takes more time for vacuum drying. If you have time to spare, you may use the same vacuum pump, but if you want to

Все каталоги и инструкции здесь: <https://splitsystema48.ru/instrukcii-po-ekspluatacii-kondicionerov.html>

### 1. vacuum pump performance

The 2 most important things for determining vacuum pump performance are as follows:

- (1) Exhaust velocity
- (2) Degree of vacuum

#### (1) Exhaust velocity

Exhaust volume is usually expressed as l/min or m<sup>3</sup>/h. The larger the number, the faster vacuum is achieved. Generally speaking, the faster the exhaust velocity, the larger and heavier the vacuum pump itself is. Commercially available vacuum pumps (exhaust velocity of 20 - 30 l/min) usually take an extremely long time to achieve vacuum. (We recommend a vacuum pump of approx. 60 - 100 l/min.)

#### (2) Degree of vacuum

Ultimate vacuum varies largely according to use of the vacuum pump. Vacuum pumps used for vacuum forming cannot be used for vacuum drying. (A vacuum pump with a high degree of vacuum is required.)

When selecting a vacuum, you should select one which is capable of achieving 0.2 Torr of ultimate vacuum.

Degree of vacuum is expressed in Torr, micron, mmHg, and Pascal (Pa). The units correlate as follows:

	Unit	Standard atmospheric pressure	Perfect vacuum
Gauge pressure	kg/cm <sup>2</sup>	0	-1.033
Absolute pressure	kg/cm <sup>2</sup> abs	1.033	0
Torr	Torr	760	0
Micron	Micron	760000	0
* cmHg	cmHg	0	76
Pa	hPa	1013.33	0

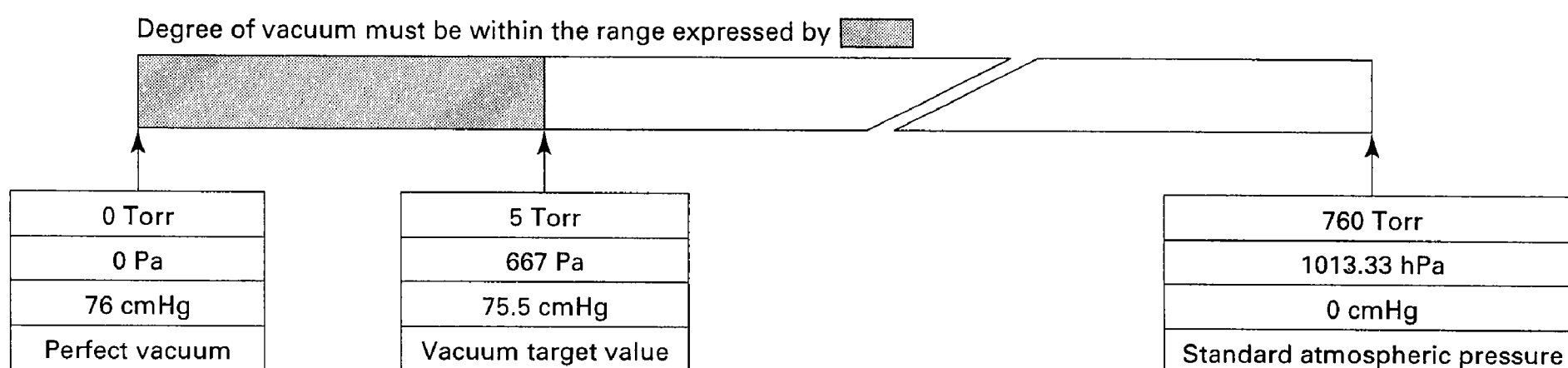



## 2. Vacuum pump maintenance

Because of their nature, most vacuum pumps contain large amounts of oil which lubricates bearings, etc., and functions to enhance airtightness of pistons. When using a vacuum pump to discharge air from refrigerant piping, moisture in the air tends to get mixed in with the oil. You must therefore change oil periodically and make sure the proper oil level is maintained. (Perform periodic inspections in accordance with the operating instructions.)

Все каталоги и инструкции здесь: <https://splitsystema48.ru/instrukcii-po-ekspluatacii-kondicionerov.html>

An extremely accurate vacuum gauge is required to test degree of vacuum. You cannot accurately measure degree of vacuum with the compound gauge on the gauge manifold. A Pirani vacuum gauge is required to measure degree of vacuum accurately. Because Pirani gauges are very sensitive and require extreme care when using, they are not very suitable for use in the field. You should therefore use the Pirani gauge to calibrate the attached vacuum gauge on the gauge manifold and the degree of vacuum of the vacuum pump.

## 4. Calibration method

1. Connect a Pirani vacuum gauge and the gauge manifold vacuum gauge (0 - 76 cmHg) to the vacuum pump at the same time, and run the pump for about 3 minutes.
2. Make sure the reading of the Pirani vacuum gauge is 5 Torr (667 Pa ) or less. The reading of conventional vacuum pumps lowers to about 0.2 Torr.

If the reading is not 5 Torr or less, check the vacuum pump oil. (Oil is low in many cases.)

3. Check the attached gauge on the gauge manifold. Adjust the gauge if the reading is not exactly correct.
4. Adjust the gauge manifold valve so that the Pirani vacuum gauge reads 5 Torr.
5. Mark the position indicated by the gauge manifold gauge with an oil based ink pen.
6. Use the mark of the gauge manifold as a target when vacuuming in the field.

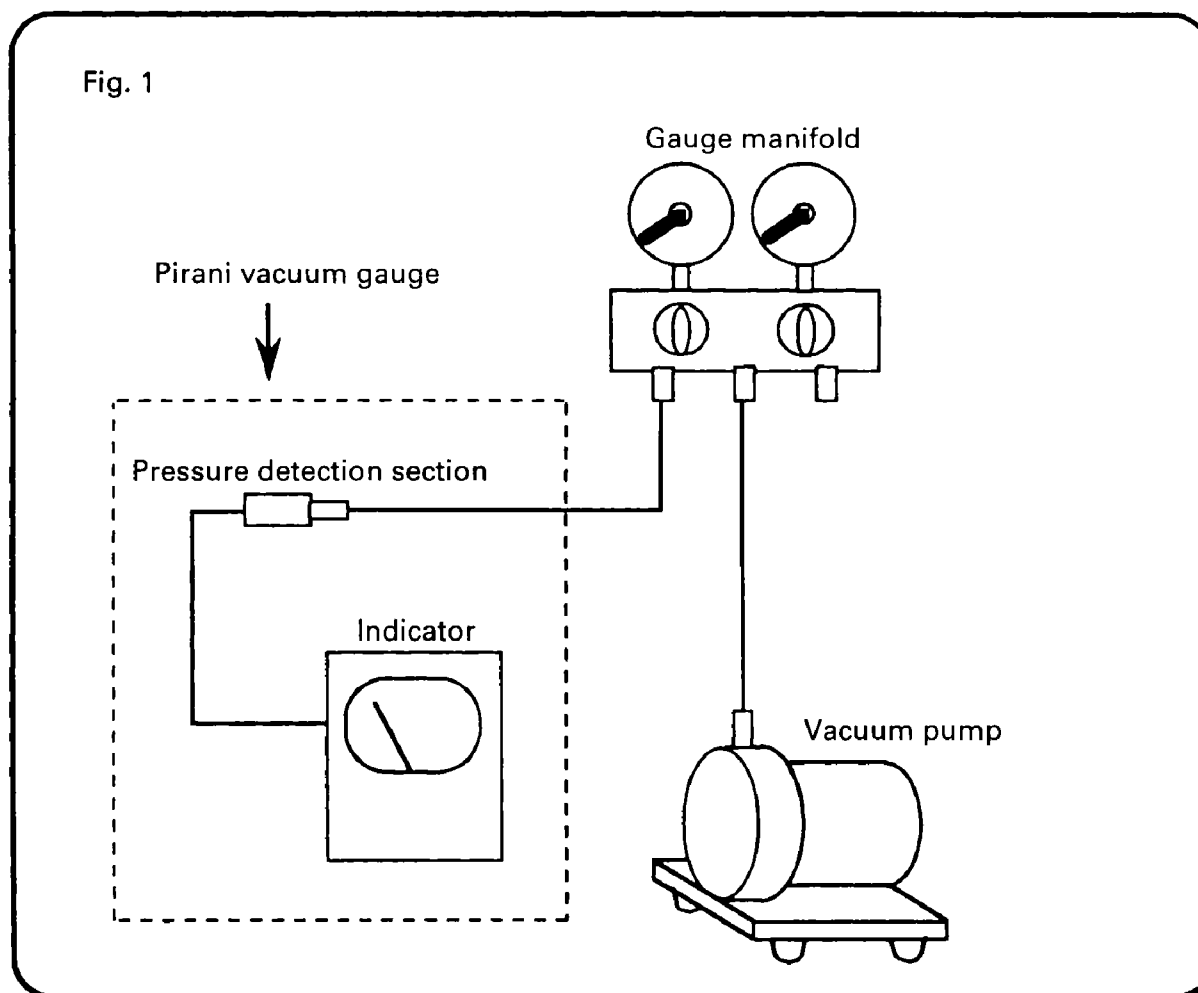

## 2. VRV Inspection Sheet

Inspection date: \_\_\_\_\_

Delivery date: \_\_\_\_\_

Transfer date: \_\_\_\_\_

Owner		System name	
-------	--	-------------	--

Все каталоги и инструкции здесь: <https://splitsystema48.ru/instrukcii-po-ekspluatacii-kondicionerov.html>

	Installation location	Model	Unit No.
Function unit			
Inverter outdoor unit			
Constant speed outdoor unit 1			
Constant speed outdoor unit 2			

### Indoor units

No.	Installation location	Model	Unit No.	Group No.	No.	Installation location	Model	Unit No.	Group No.
1					16				
2					17				
3					18				
4					19				
5					20				
6					21				
7					22				
8					23				
9					24				
10					25				
11					26				
12					27				
13					28				
14					29				
15					30				

### Field settings

C/H SELECT (setting mode 1)			C/H SELECT setting (SS1)			Low noise operation			Sequential start	
IND	MASTER	SLAVE	IN/D	OUT/D		ON	OFF	ON	OFF	
Tc			Te			Defrost SETTING			Refrigerant addition/replenishment	
H	M	L	H	M	L	H	M	L	kg	

Company name \_\_\_\_\_

Inspector \_\_\_\_\_

Before turning on the power

System name

Function unit	Inspection item	Inspection method	Standard (guideline)	Measurement values					Decision				
	Breaker capacity	Visual inspection	Specified capacity	G NG									
Function unit	Refrigerant piping system	Gas detector	No leaks	G NG									
	Terminal connection section	Screwdriver, etc.	No looseness	G NG									
<p><b>Все каталоги и инструкции здесь:</b> <a href="https://splitsystema48.ru/instrukcii-po-ekspluatcii-kondicionerov.html">https://splitsystema48.ru/instrukcii-po-ekspluatcii-kondicionerov.html</a></p>													
Inverter type outdoor unit	Terminal connection section	Screwdriver, etc.	No looseness	G NG									
	Fan motor thermal insulation	500-V megatester	1 MΩ or more	MΩ									
	Compressor thermal insulation	500-V megatester	1 MΩ or more	MΩ		MΩ							
Standard type outdoor unit 1	Installation	Visual inspection	Short circuit, etc.	G NG									
	Refrigerant piping system	Gas detector	No leaks	G NG									
	Heat exchanger	Visual inspection	No clogging or damage	G NG									
	Terminal connection section	Screwdriver, etc.	No looseness	G NG									
	Fan motor thermal insulation	500-V megatester	1 MΩ or more	MΩ									
	Compressor thermal insulation	500-V megatester	1 MΩ or more	MΩ		MΩ							
Standard type outdoor unit 2	Installation	Visual inspection	Short circuit, etc.	G NG									
	Refrigerant piping system	Gas detector	No leaks	G NG									
	Heat exchanger	Visual inspection	No clogging or damage	G NG									
	Terminal connection section	Screwdriver, etc.	No looseness	G NG									
	Fan motor thermal insulation	500-V megatester	1 MΩ or more	MΩ									
	Compressor thermal insulation	500-V megatester	1 MΩ or more	MΩ		MΩ							
Indoor unit	Refrigerant system	Gas detector	No leaks	Room 1	G NG	Room 2	G NG	Room 3	G NG	Room 4	G NG	Room 5	G NG
				Room 6	G NG	Room 7	G NG	Room 8	G NG	Room 9	G NG	Room10	G NG
				Room11	G NG	Room12	G NG	Room13	G NG	Room14	G NG	Room15	G NG
				Room16	G NG	Room17	G NG	Room18	G NG	Room19	G NG	Room20	G NG
				Room21	G NG	Room22	G NG	Room23	G NG	Room24	G NG	Room25	G NG
				Room26	G NG	Room27	G NG	Room28	G NG	Room29	G NG	Room30	G NG
	Air filter	Visual inspection	No clogging or damage	Room 1	G NG	Room 2	G NG	Room 3	G NG	Room 4	G NG	Room 5	G NG
				Room 6	G NG	Room 7	G NG	Room 8	G NG	Room 9	G NG	Room10	G NG
				Room11	G NG	Room12	G NG	Room13	G NG	Room14	G NG	Room15	G NG
				Room16	G NG	Room17	G NG	Room18	G NG	Room19	G NG	Room20	G NG
				Room21	G NG	Room22	G NG	Room23	G NG	Room24	G NG	Room25	G NG
				Room26	G NG	Room27	G NG	Room28	G NG	Room29	G NG	Room30	G NG
	Heat exchanger	Visual inspection	No clogging or damage	Room 1	G NG	Room 2	G NG	Room 3	G NG	Room 4	G NG	Room 5	G NG
				Room 6	G NG	Room 7	G NG	Room 8	G NG	Room 9	G NG	Room10	G NG
				Room11	G NG	Room12	G NG	Room13	G NG	Room14	G NG	Room15	G NG
				Room16	G NG	Room17	G NG	Room18	G NG	Room19	G NG	Room20	G NG
				Room21	G NG	Room22	G NG	Room23	G NG	Room24	G NG	Room25	G NG
				Room26	G NG	Room27	G NG	Room28	G NG	Room29	G NG	Room30	G NG
	Fan motor thermal insulation	500-V megatester	1 MΩ or more	Room 1	MΩ	Room 2	MΩ	Room 3	MΩ	Room 4	MΩ	Room 5	MΩ
				Room 6	MΩ	Room 7	MΩ	Room 8	MΩ	Room 9	MΩ	Room10	MΩ
				Room11	MΩ	Room12	MΩ	Room13	MΩ	Room14	MΩ	Room15	MΩ
				Room16	MΩ	Room17	MΩ	Room18	MΩ	Room19	MΩ	Room20	MΩ
				Room21	MΩ	Room22	MΩ	Room23	MΩ	Room24	MΩ	Room25	MΩ
				Room26	MΩ	Room27	MΩ	Room28	MΩ	Room29	MΩ	Room30	MΩ
Auxiliary heater thermal insulation	500-V megatester	1 MΩ or more	Room 1	MΩ	Room 2	MΩ	Room 3	MΩ	Room 4	MΩ	Room 5	MΩ	
			Room 6	MΩ	Room 7	MΩ	Room 8	MΩ	Room 9	MΩ	Room10	MΩ	
			Room11	MΩ	Room12	MΩ	Room13	MΩ	Room14	MΩ	Room15	MΩ	
			Room16	MΩ	Room17	MΩ	Room18	MΩ	Room19	MΩ	Room20	MΩ	
			Room21	MΩ	Room22	MΩ	Room23	MΩ	Room24	MΩ	Room25	MΩ	
			Room26	MΩ	Room27	MΩ	Room28	MΩ	Room29	MΩ	Room30	MΩ	
Installation	Visual inspection	Short circuit, etc.	Room 1	G NG	Room 2	G NG	Room 3	G NG	Room 4	G NG	Room 5	G NG	
			Room 6	G NG	Room 7	G NG	Room 8	G NG	Room 9	G NG	Room10	G NG	
			Room11	G NG	Room12	G NG	Room13	G NG	Room14	G NG	Room15	G NG	
			Room16	G NG	Room17	G NG	Room18	G NG	Room19	G NG	Room20	G NG	
			Room21	G NG	Room22	G NG	Room23	G NG	Room24	G NG	Room25	G NG	
			Room26	G NG	Room27	G NG	Room28	G NG	Room29	G NG	Room30	G NG	

During operation

System name

	Inspection item	Inspection method	Standard (guideline)	Measurement values				Decision	
Function unit	Power supply voltage	Tester	Rated voltage $\pm 10\%$	V					
	Main power supply voltage	Tester	Rated voltage $\pm 10\%$	R-S	V	S-T	V	R-T	V
<p><b>Все каталоги и инструкции здесь:</b> <a href="https://splitsystema48.ru/instrukcii-po-ekspluatacii-kondicionerov.html">https://splitsystema48.ru/instrukcii-po-ekspluatacii-kondicionerov.html</a></p>				V					
Inverter type outdoor unit	Fan rotation direction	Visual inspection	Forward rotation	G NG					
	Fan noise/vibration	Listening	No noise or vibration						
	Fan operating current	Clamp meter		A					
	Suction air temperature	Thermometer	Temperature differential	°C					
	Discharge air temperature	Thermometer	9~11°C when cooling, 2~3.5°C when heating	°C					
	Compressor suction pressure	Pressure gauge		INV	kg/cm <sup>2</sup>	STD	kg/cm <sup>2</sup>		
	Compressor discharge pressure	Pressure gauge		INV	kg/cm <sup>2</sup>	STD	kg/cm <sup>2</sup>		
	Compressor operating current	Clamp meter	Phase differential within 1A	INV	A	STD	A		
	Compressor operating frequency	Clamp meter		Hz					
	Suction pipe temperature	Thermometer	3~15°C	INV	°C	STD	°C		
	Discharge pipe temperature	Thermometer	85~105°C	INV	°C	STD	°C		
	Crankcase heater	Touch	Warm	INV	G NG	STD	G NG		
Standard type outdoor unit 1	Main power supply voltage	Tester	Rated voltage $\pm 10\%$	R-S	V	S-T	V	R-T	V
	Operation circuit voltage	Tester	Rated voltage $\pm 10\%$	V					
	Fan rotation direction	Visual inspection	Forward rotation	G NG					
	Fan noise/vibration	Listening	No noise or vibration						
	Fan operating current	Clamp meter		A					
	Suction air temperature	Thermometer	Temperature differential	°C					
	Discharge air temperature	Thermometer	9~11°C when cooling, 2~3.5°C when heating	°C					
	Compressor suction pressure	Pressure gauge		STD1	kg/cm <sup>2</sup>	STD2	kg/cm <sup>2</sup>		
	Compressor discharge pressure	Pressure gauge		STD1	kg/cm <sup>2</sup>	STD2	kg/cm <sup>2</sup>		
	Compressor operating current	Clamp meter	Phase differential within 1A	STD1	A	STD2	A		
	Suction pipe temperature	Thermometer	3~15°C	STD1	°C	STD2	°C		
	Discharge pipe temperature	Thermometer	85~105°C	STD1	°C	STD2	°C		
Crankcase heater	Touch	Warm	STD1	G NG	STD2	G NG			
Standard type outdoor unit 2	Main power supply voltage	Tester	Rated voltage $\pm 10\%$	R-S	V	S-T	V	R-T	V
	Operation circuit voltage	Tester	Rated voltage $\pm 10\%$	V					
	Fan rotation direction	Visual inspection	Forward rotation	G NG					
	Fan noise/vibration	Listening	No noise or vibration						
	Fan operating current	Clamp meter		A					
	Suction air temperature	Thermometer	Temperature differential	°C					
	Discharge air temperature	Thermometer	9~11°C when cooling, 2~3.5°C when heating	°C					
	Compressor suction pressure	Pressure gauge		STD1	kg/cm <sup>2</sup>	STD2	kg/cm <sup>2</sup>		
	Compressor discharge pressure	Pressure gauge		STD1	kg/cm <sup>2</sup>	STD2	kg/cm <sup>2</sup>		
	Compressor operating current	Clamp meter	Phase differential within 1A	STD1	A	STD2	A		
	Suction pipe temperature	Thermometer	3~15°C	STD1	°C	STD2	°C		
	Discharge pipe temperature	Thermometer	85~105°C	STD1	°C	STD2	°C		
Crankcase heater	Touch	Warm	STD1	G NG	STD2	G NG			

During operation

System name

	Inspection item	Inspection method	Standard (guideline)	Measurement values					Decision			
				Room 1	Room 2	Room 3	Room 4	Room 5				
Indoor unit				Room 1 V	Room 2 V	Room 3 V	Room 4 V	Room 5 V				
				Room 6 V	Room 7 V	Room 8 V	Room 9 V	Room10 V				
								Room15 V				
					Room16 V	Room17 V	Room18 V	Room19 V	Room20 V			
					Room21 V	Room22 V	Room23 V	Room24 V	Room25 V			
					Room26 V	Room27 V	Room28 V	Room29 V	Room30 V			
		Suction air temperature	Thermometer	Temperature differential 9~13°C when cooling, 15~20°C when heating	Room 1 °C	Room 2 °C	Room 3 °C	Room 4 °C	Room 5 °C			
					Room 6 °C	Room 7 °C	Room 8 °C	Room 9 °C	Room10 °C			
					Room11 °C	Room12 °C	Room13 °C	Room14 °C	Room15 °C			
					Room16 °C	Room17 °C	Room18 °C	Room19 °C	Room20 °C			
					Room21 °C	Room22 °C	Room23 °C	Room24 °C	Room25 °C			
					Room26 °C	Room27 °C	Room28 °C	Room29 °C	Room30 °C			
		Discharge air temperature					Room 1 °C	Room 2 °C	Room 3 °C	Room 4 °C	Room 5 °C	
							Room 6 °C	Room 7 °C	Room 8 °C	Room 9 °C	Room10 °C	
							Room11 °C	Room12 °C	Room13 °C	Room14 °C	Room15 °C	
							Room16 °C	Room17 °C	Room18 °C	Room19 °C	Room20 °C	
							Room21 °C	Room22 °C	Room23 °C	Room24 °C	Room25 °C	
							Room26 °C	Room27 °C	Room28 °C	Room29 °C	Room30 °C	
		Fan rotation direction	Visual inspection	Forward rotation	Room 1 G NG	Room 2 G NG	Room 3 G NG	Room 4 G NG	Room 5 G NG			
					Room 6 G NG	Room 7 G NG	Room 8 G NG	Room 9 G NG	Room10 G NG			
					Room11 G NG	Room12 G NG	Room13 G NG	Room14 G NG	Room15 G NG			
					Room16 G NG	Room17 G NG	Room18 G NG	Room19 G NG	Room20 G NG			
					Room21 G NG	Room22 G NG	Room23 G NG	Room24 G NG	Room25 G NG			
					Room26 G NG	Room27 G NG	Room28 G NG	Room29 G NG	Room30 G NG			
		Fan noise / vibration	Listening	No noise or vibration	Room 1 G NG	Room 2 G NG	Room 3 G NG	Room 4 G NG	Room 5 G NG			
					Room 6 G NG	Room 7 G NG	Room 8 G NG	Room 9 G NG	Room10 G NG			
					Room11 G NG	Room12 G NG	Room13 G NG	Room14 G NG	Room15 G NG			
					Room16 G NG	Room17 G NG	Room18 G NG	Room19 G NG	Room20 G NG			
					Room21 G NG	Room22 G NG	Room23 G NG	Room24 G NG	Room25 G NG			
					Room26 G NG	Room27 G NG	Room28 G NG	Room29 G NG	Room30 G NG			
	Fan operating current	Clamp meter		Room 1 A	Room 2 A	Room 3 A	Room 4 A	Room 5 A				
				Room 6 A	Room 7 A	Room 8 A	Room 9 A	Room10 A				
				Room11 A	Room12 A	Room13 A	Room14 A	Room15 A				
				Room16 A	Room17 A	Room18 A	Room19 A	Room20 A				
				Room21 A	Room22 A	Room23 A	Room24 A	Room25 A				
				Room26 A	Room27 A	Room28 A	Room29 A	Room30 A				

Все каталоги и инструкции здесь: <https://splitsystema48.ru/instrukcii-po-ekspluatacii-kondicionerov.html>

### 3.Refrigerant piping diagram for PLUS series (Refer detail explanation to Service manual Si-05B)

#### BL2K

Все каталоги и инструкции здесь: <https://splitsystema48.ru/instrukcii-po-ekspluatacii-kondicionerov.html>

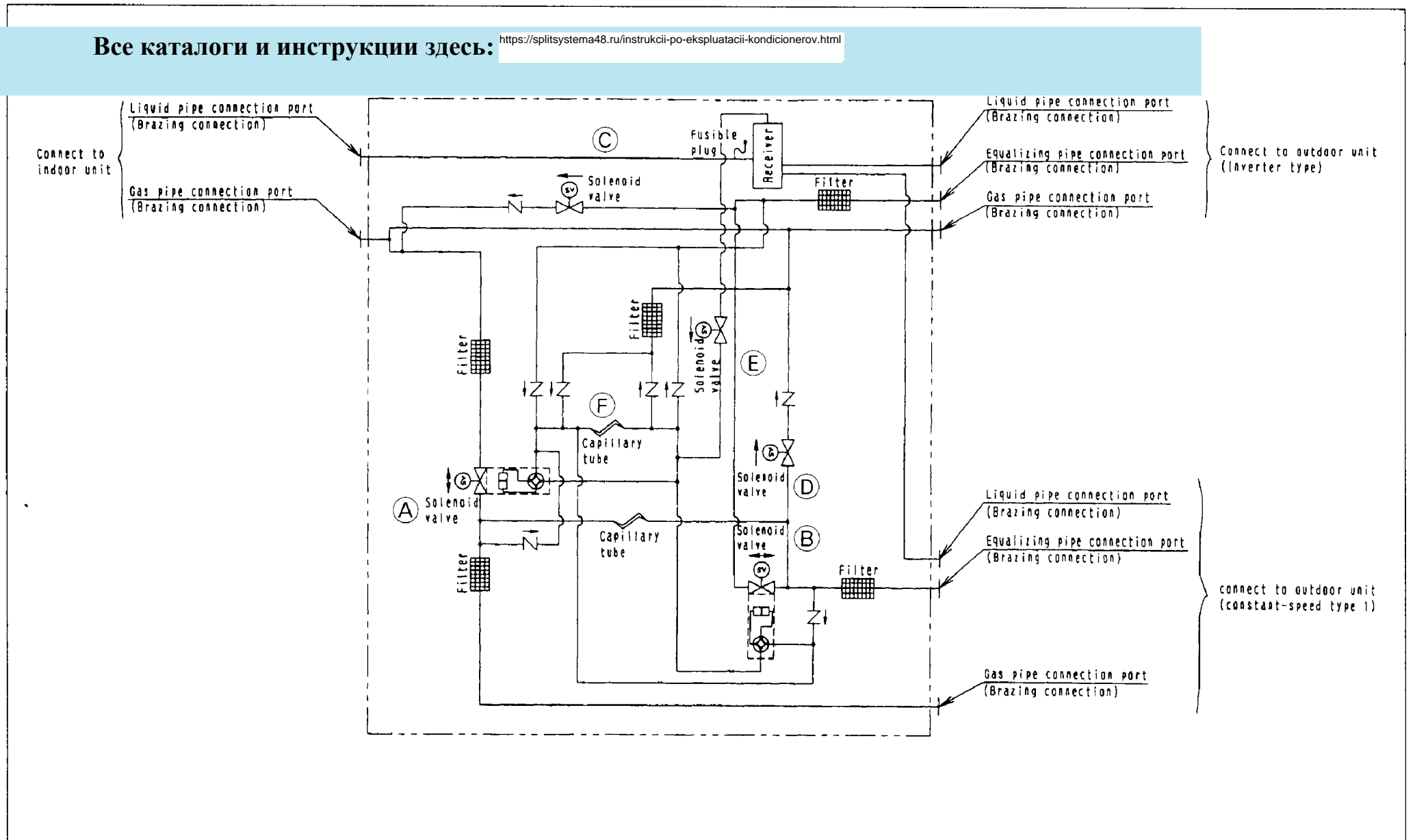

#### BL3K

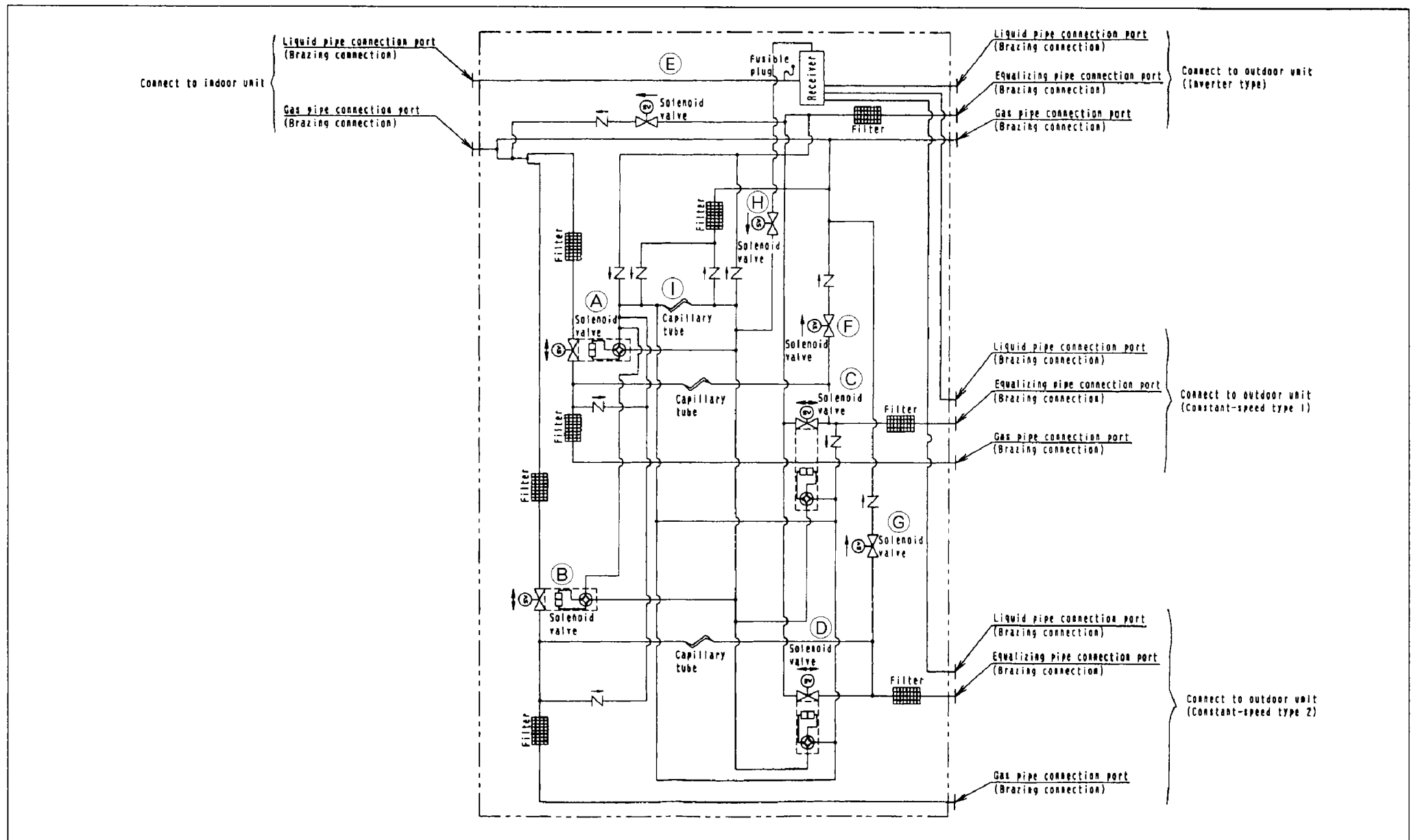

# BC2K

Все каталоги и инструкции здесь: <https://splitsystema48.ru/instrukcii-po-ekspluatacii-kondicionerov.html>

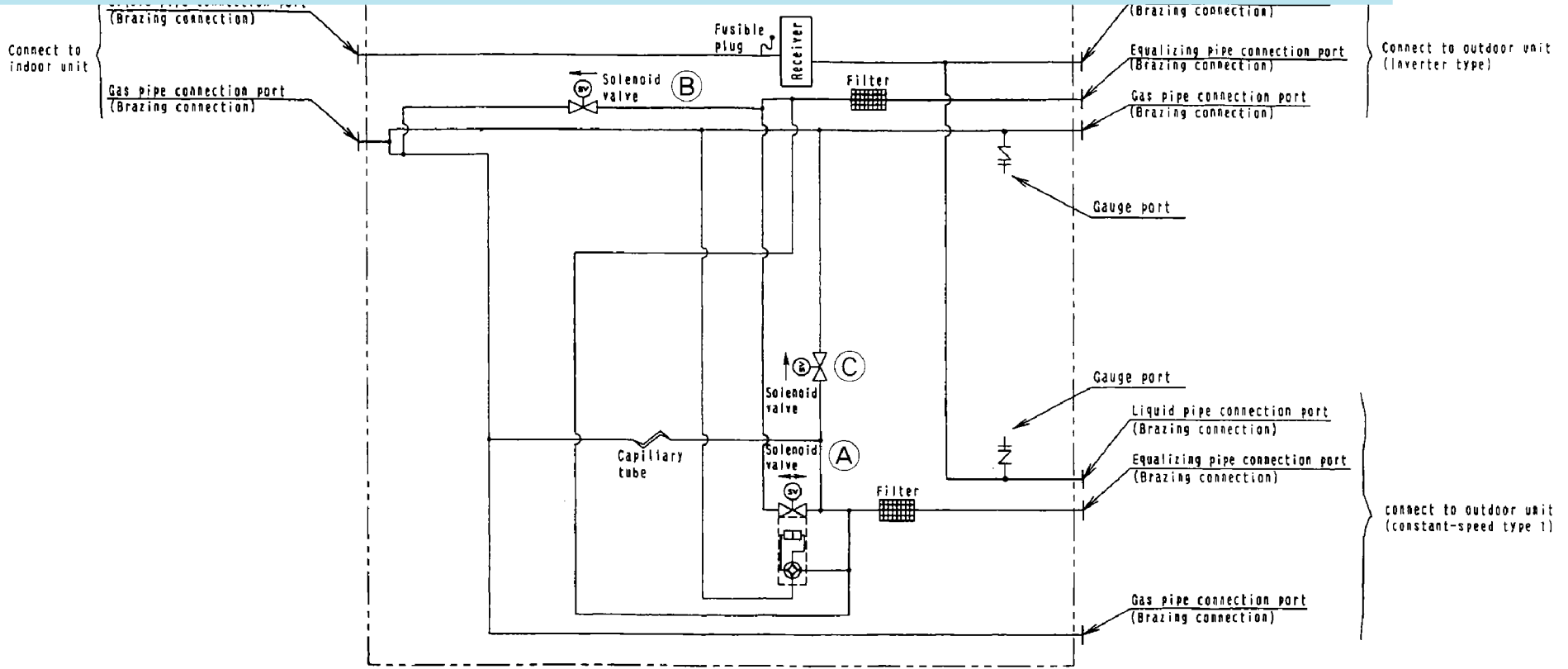

# BC3K

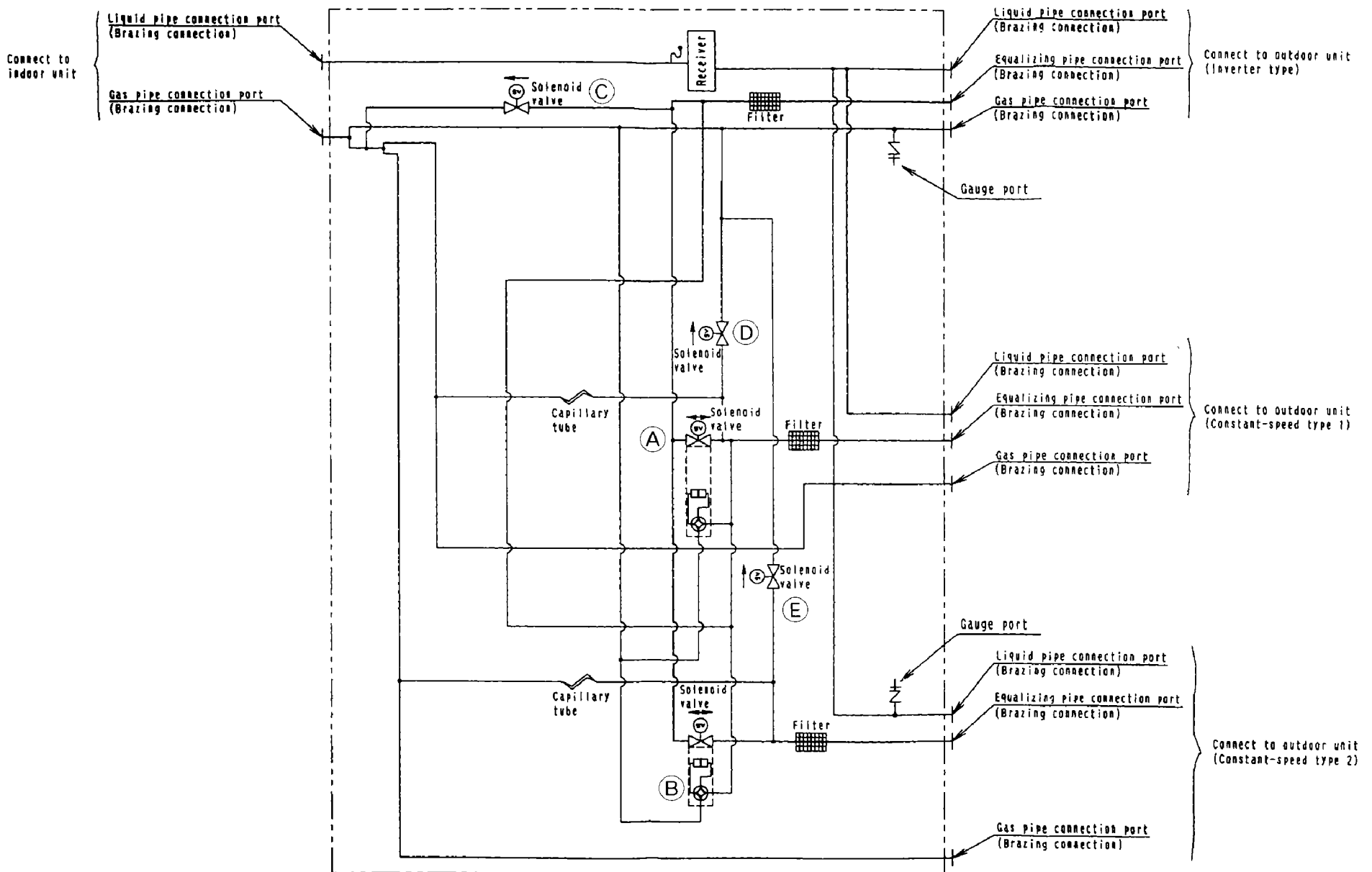

# BR2K

Все каталоги и инструкции здесь: <https://splitsystema48.ru/instrukcii-po-ekspluatacii-kondicionerov.html>

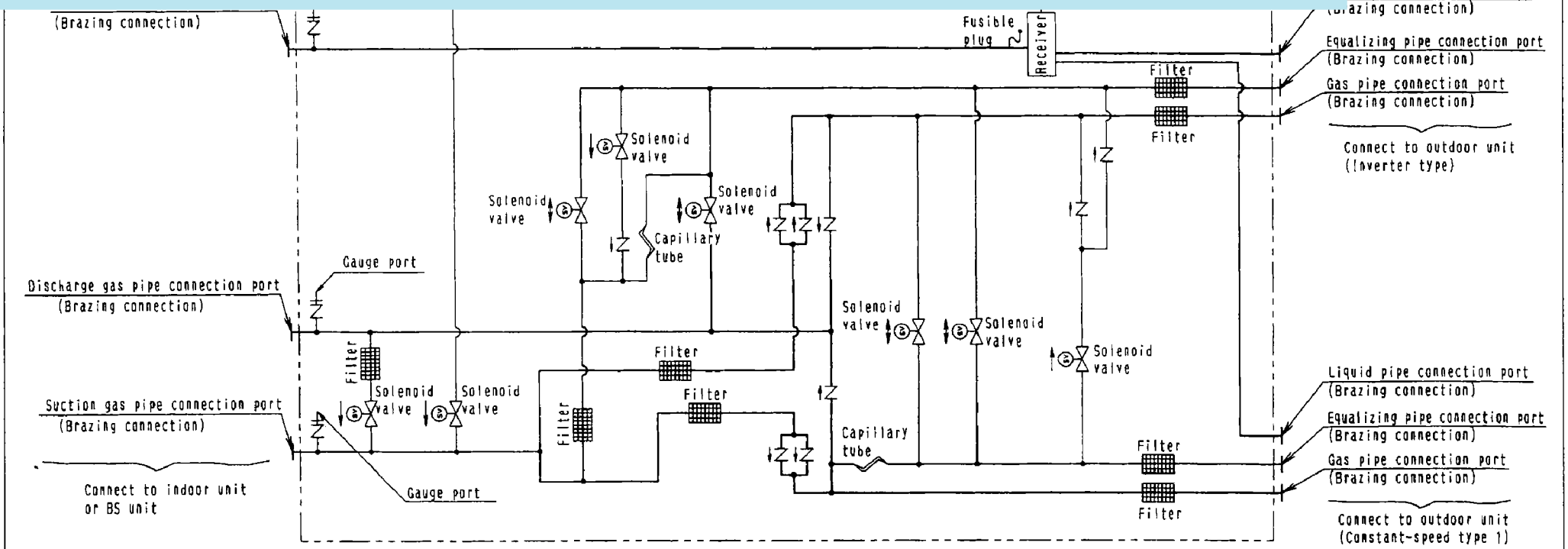

# BR3K

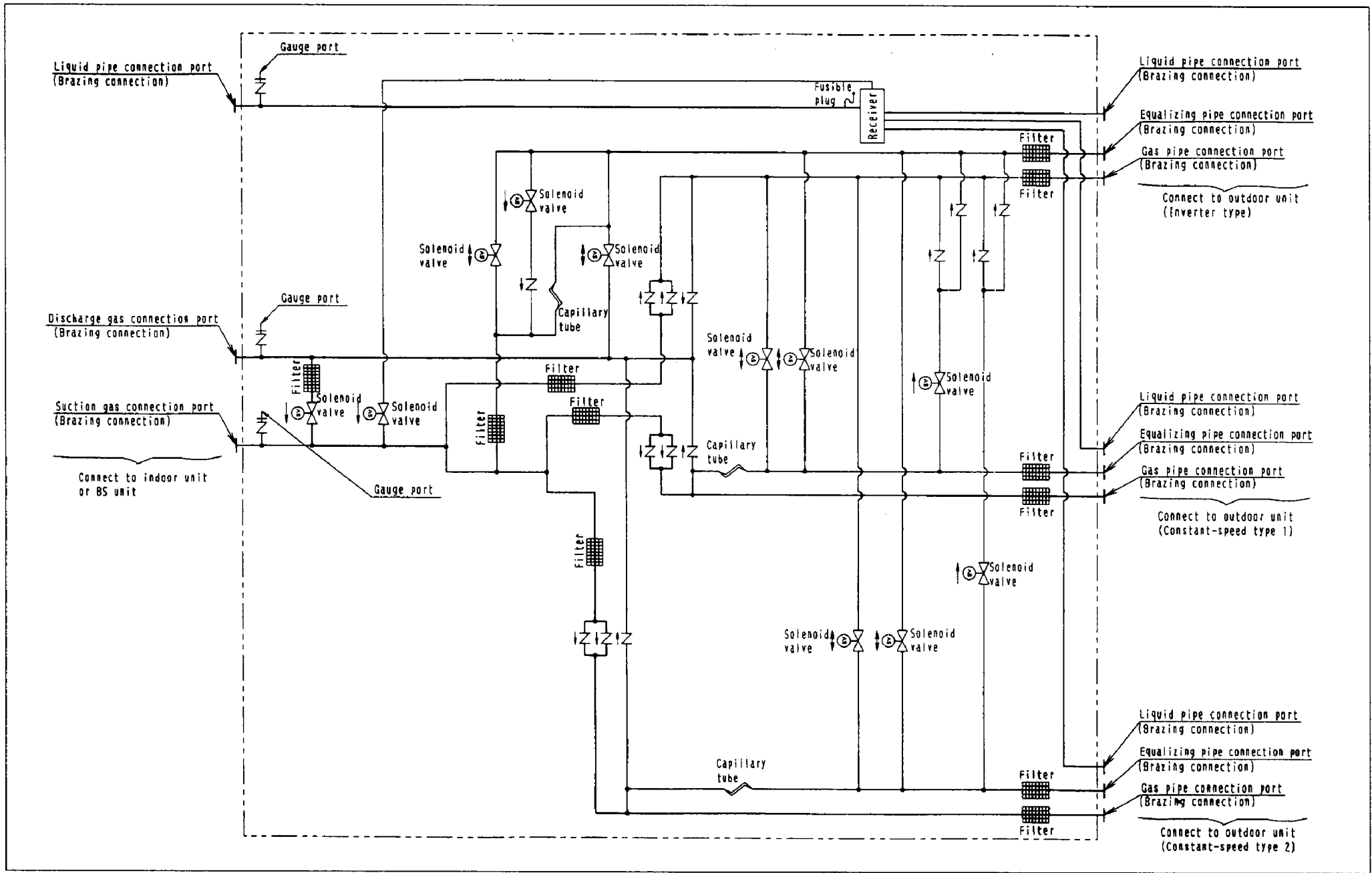



RXY8K-10K(8-10HP)

Все каталоги и инструкции здесь: <https://splitsystema48.ru/instrukcii-po-ekspluatacii-kondicionerov.html>

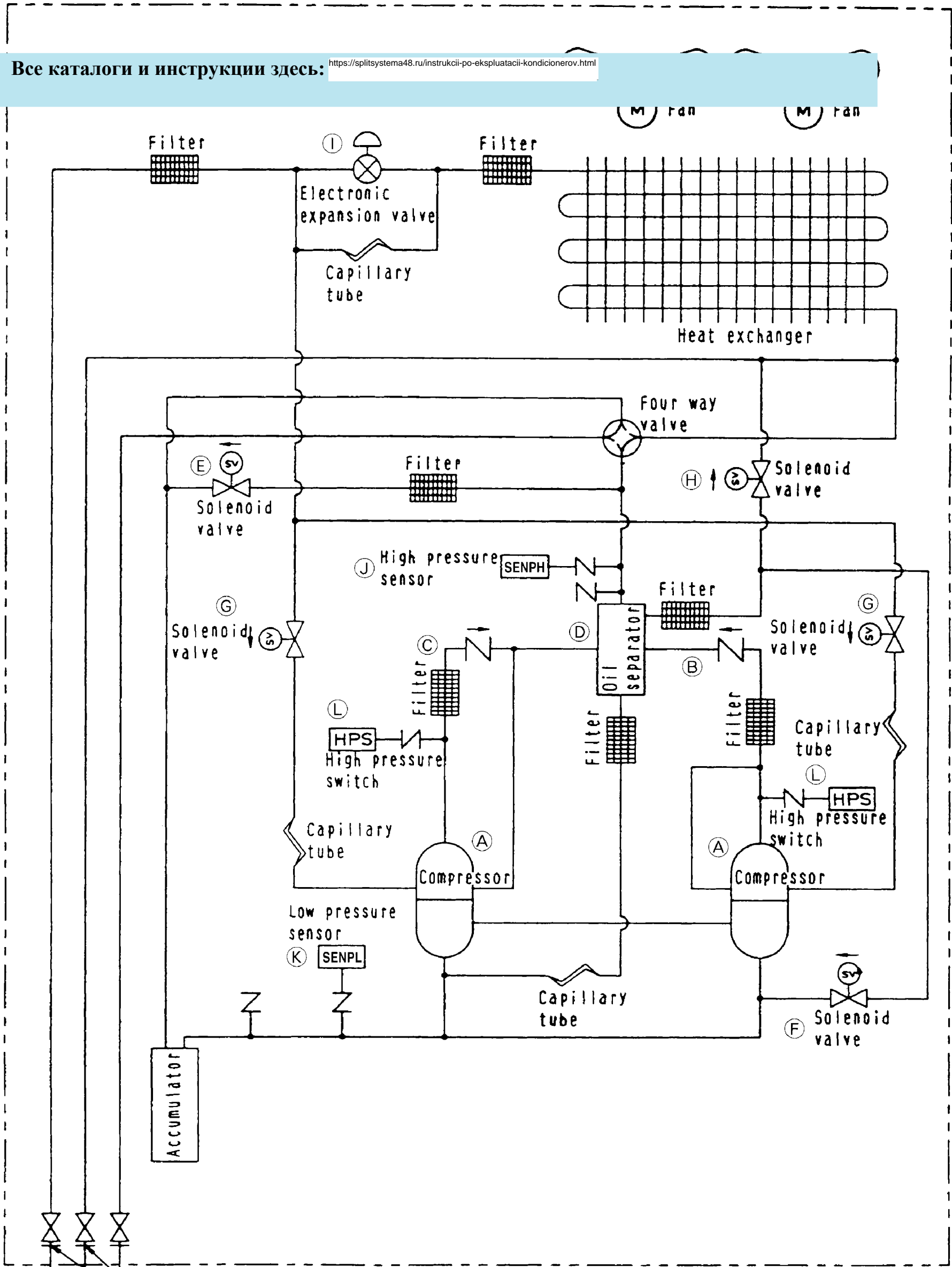

Stop valve  
(With service port on on-site piping side)

Все каталоги и инструкции здесь: <https://splitsystema48.ru/instrukcii-po-ekspluatacii-kondicionerov.html>

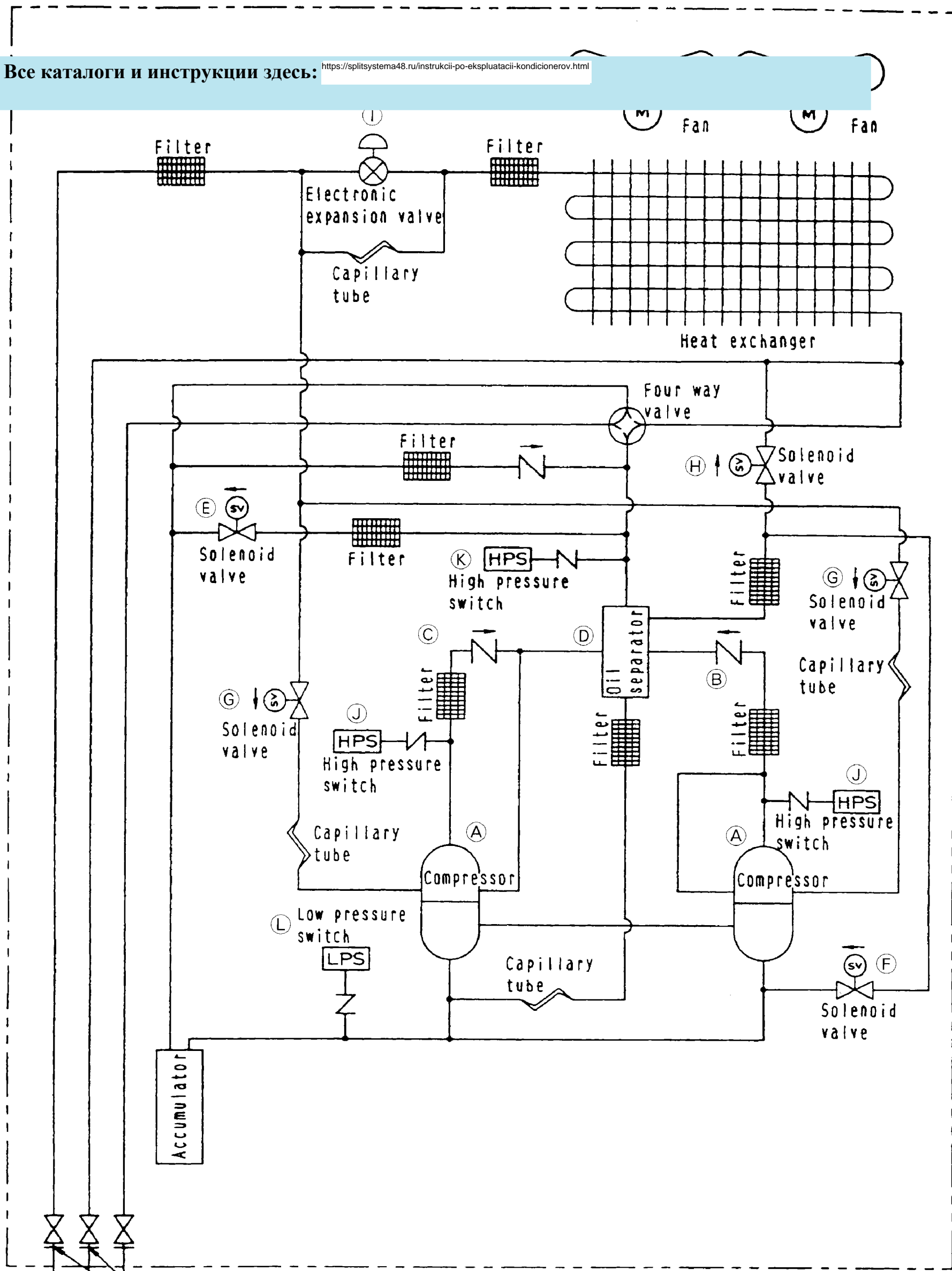

Stop valve  
(With service port on on-site piping side)

RX8K-10K(8-10HP)

Все каталоги и инструкции здесь: <https://splitsystema48.ru/instrukcii-po-ekspluatacii-kondicionerov.html>

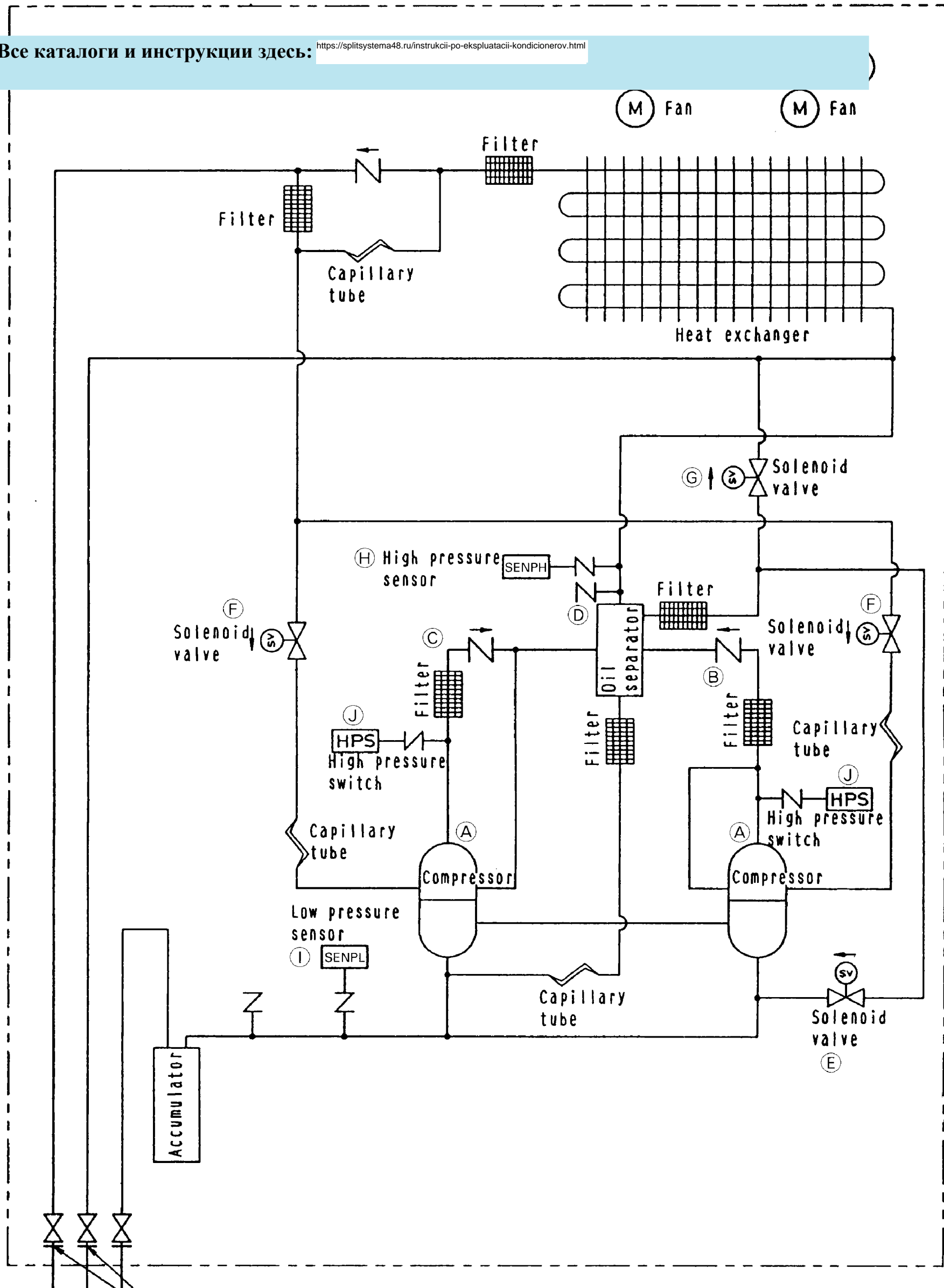

Stop valve  
(With service port on on-site piping side)

RN8K-10K(8-10HP)

Все каталоги и инструкции здесь: <https://splitsystema48.ru/instrukcii-po-ekspluatacii-kondicionerov.html>

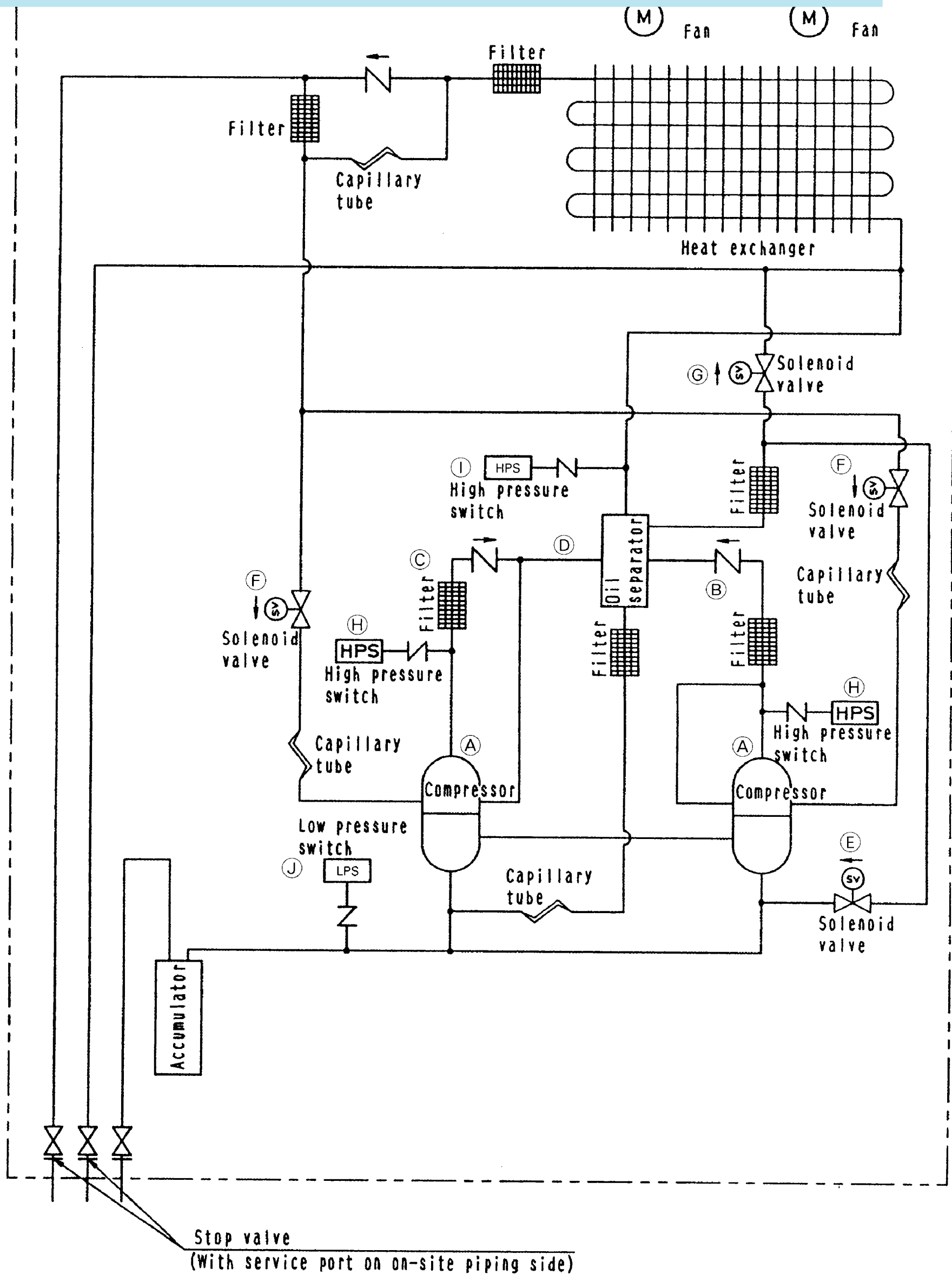

## 4. REFNET pipe connections for VRV PLUS series

### (1) REFNET JOINT (for Cooling only and heat pump system)

#### • KHRJ26K11T (less than 100)

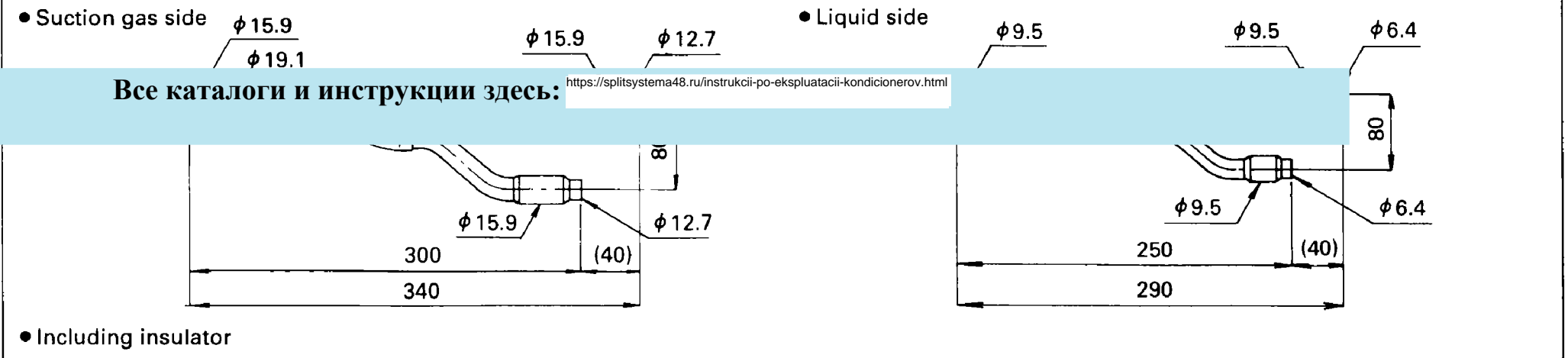

#### • KHRJ26K18T (100 or more 160)

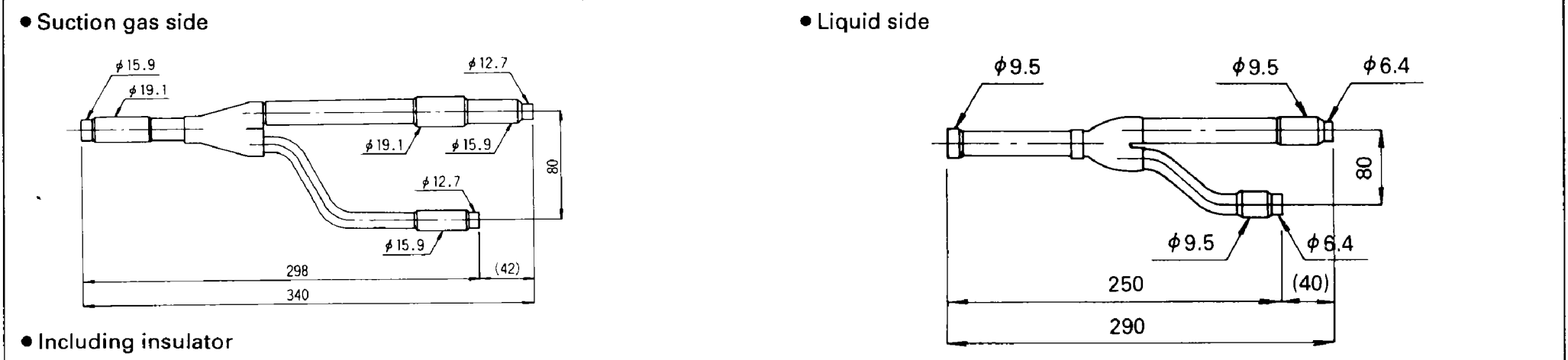

#### • KHRJ26K37T (160 or more 330)

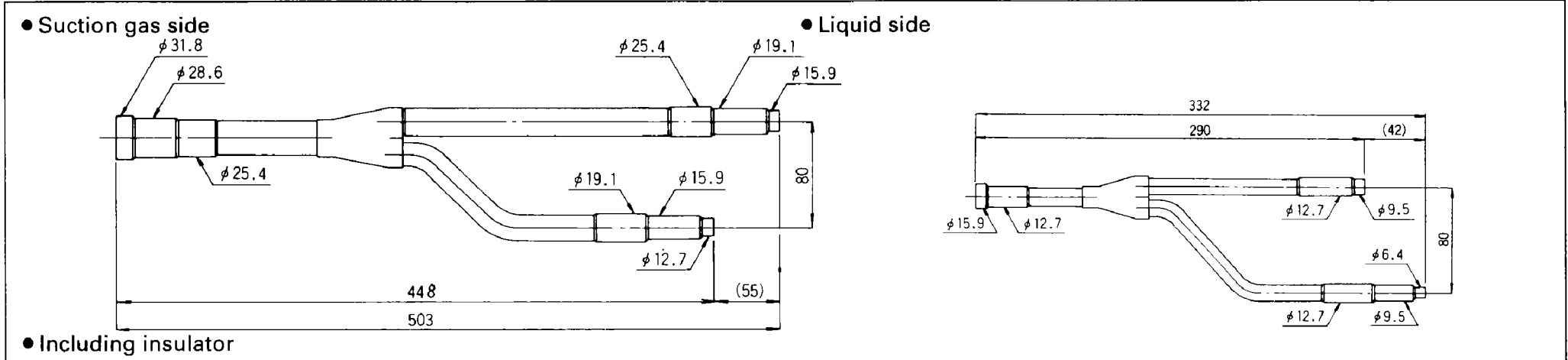

#### • KHRJ26K40T (330 or more 640)

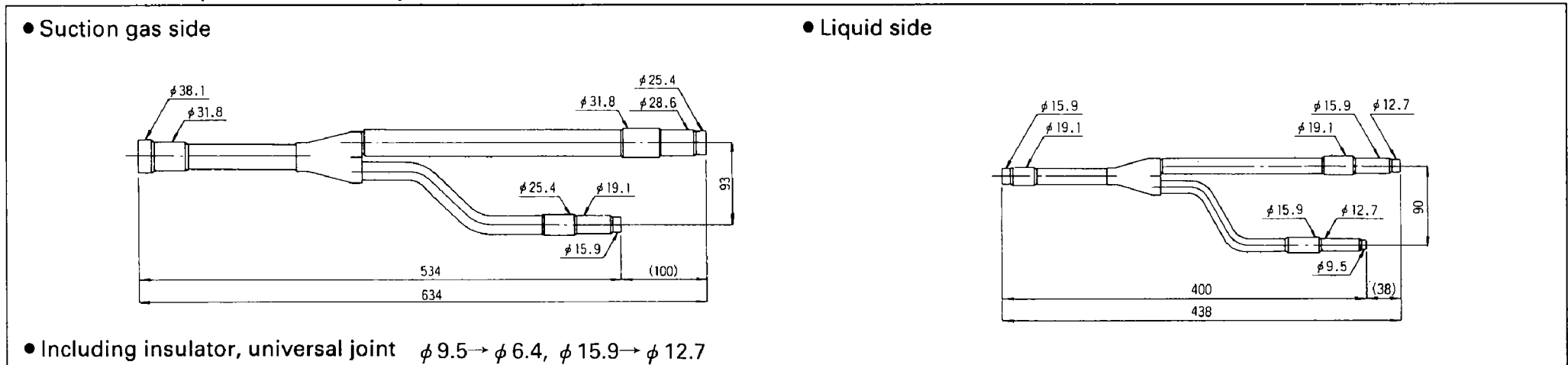

#### • KHRJ26K75T (640 or more)

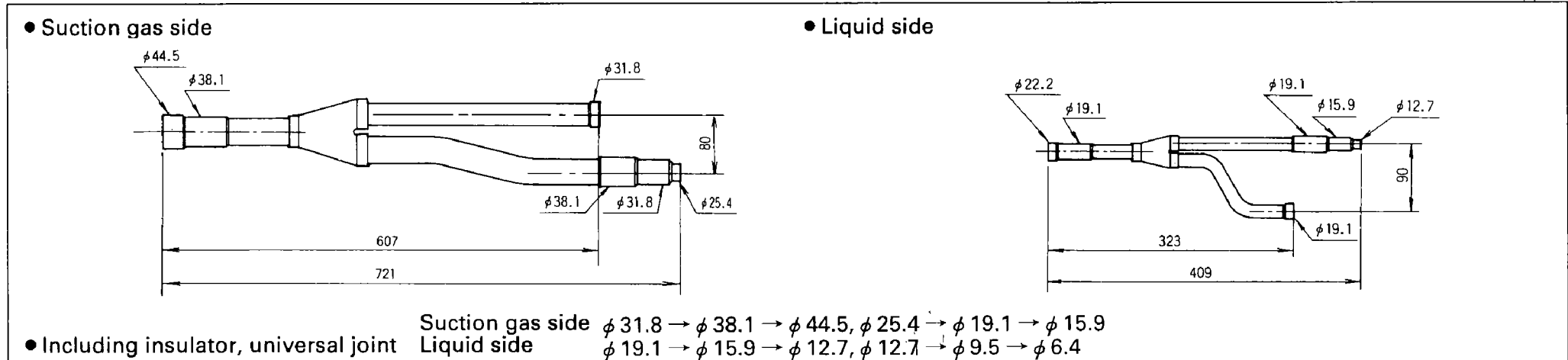

## (2) REFNET HEADER (for Cooling only and heat pump system)

### • KHRJ26K11H (4 branch fitting) (less than 100)

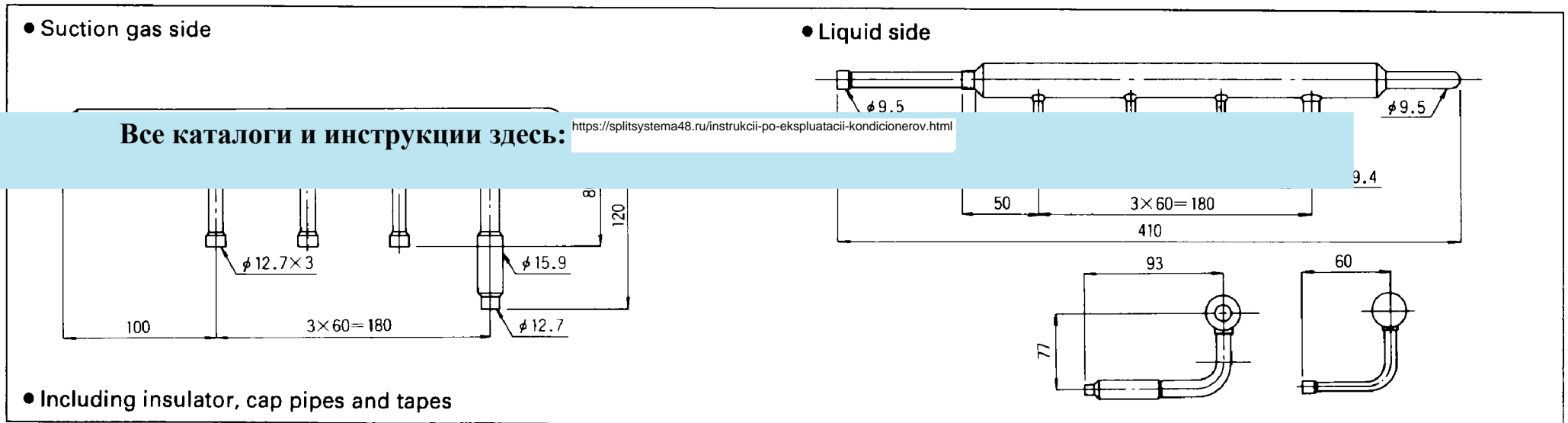

### • KHRJ26K18H (6 branch fitting) (100 or more 160)

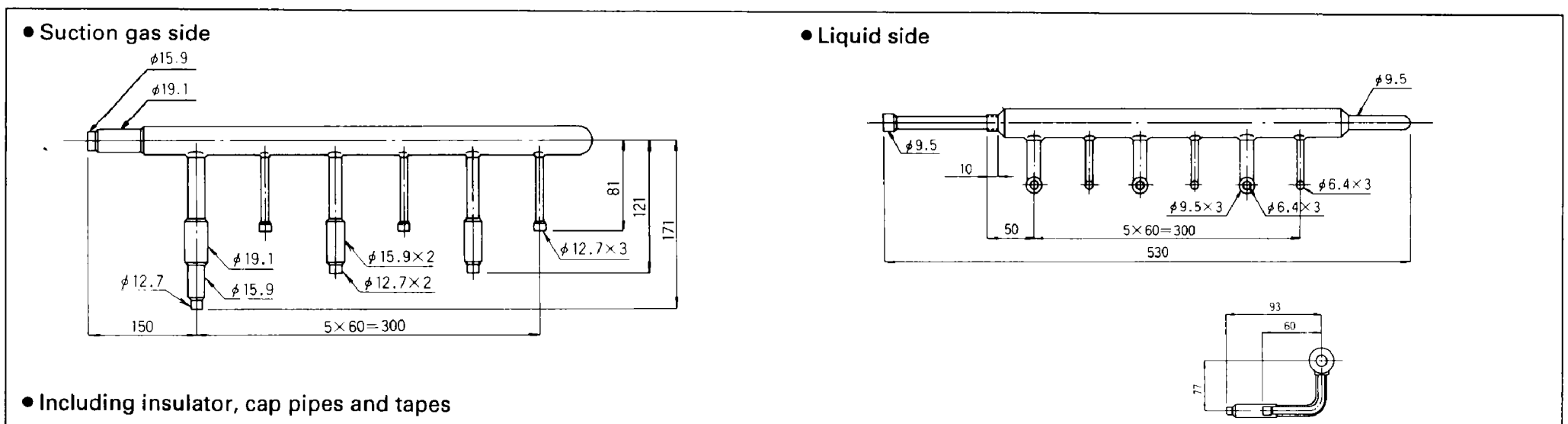

### • KHRJ26K37H (8 branch fitting) (160 or more 330)

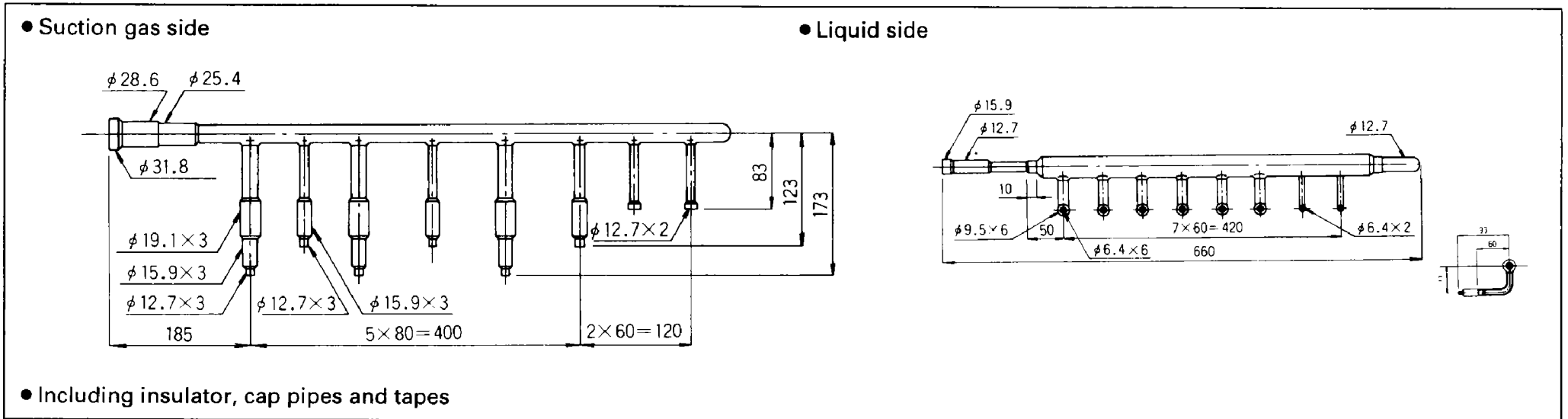

### • KHRJ26K40H (8 branch fitting) (330 or more 640)

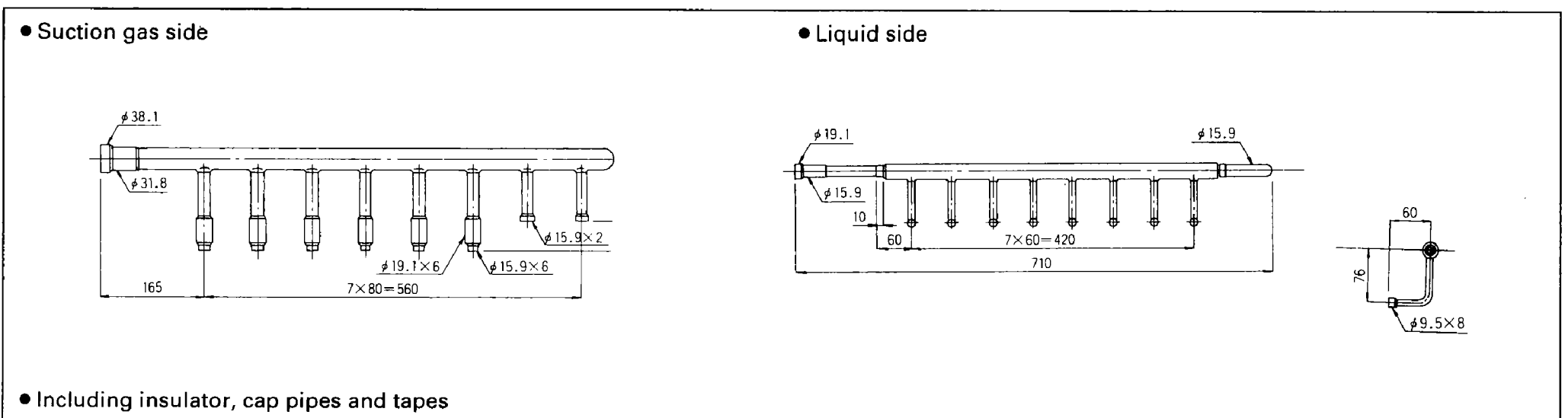

### (3) REFNET JOINT (for heat recovery system)

• KHRJ25K18T (less than 160)

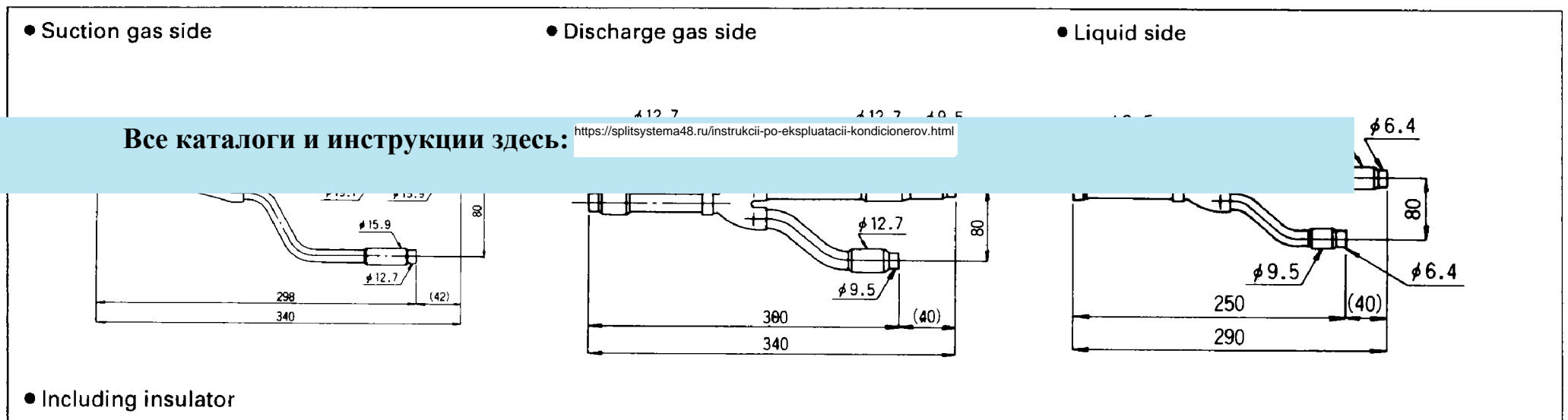

• KHRJ25K37T (160 or more 330)

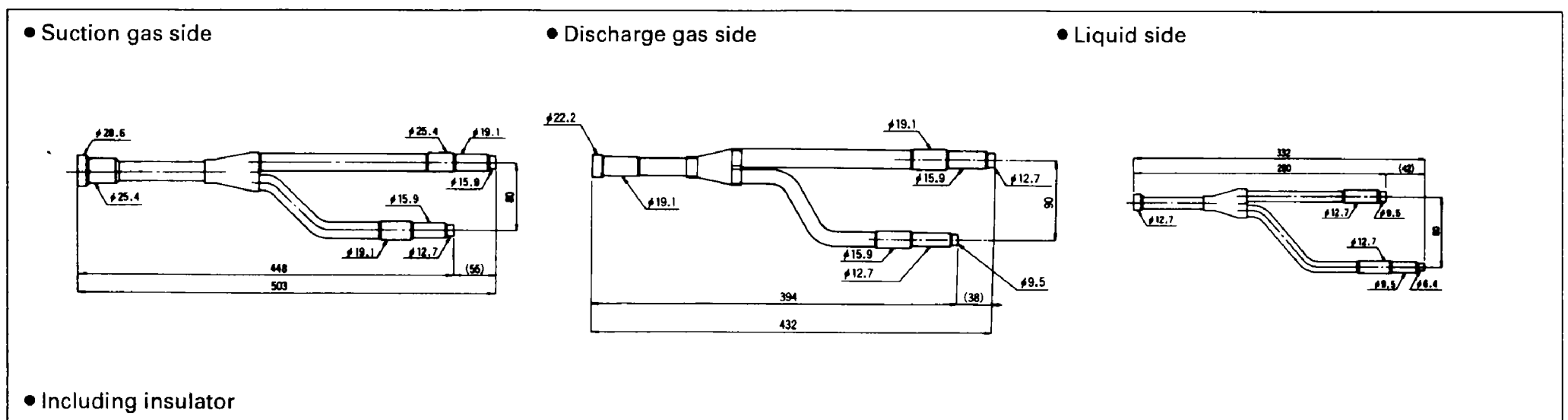

• KHRJ25K40T (330 or more 640)

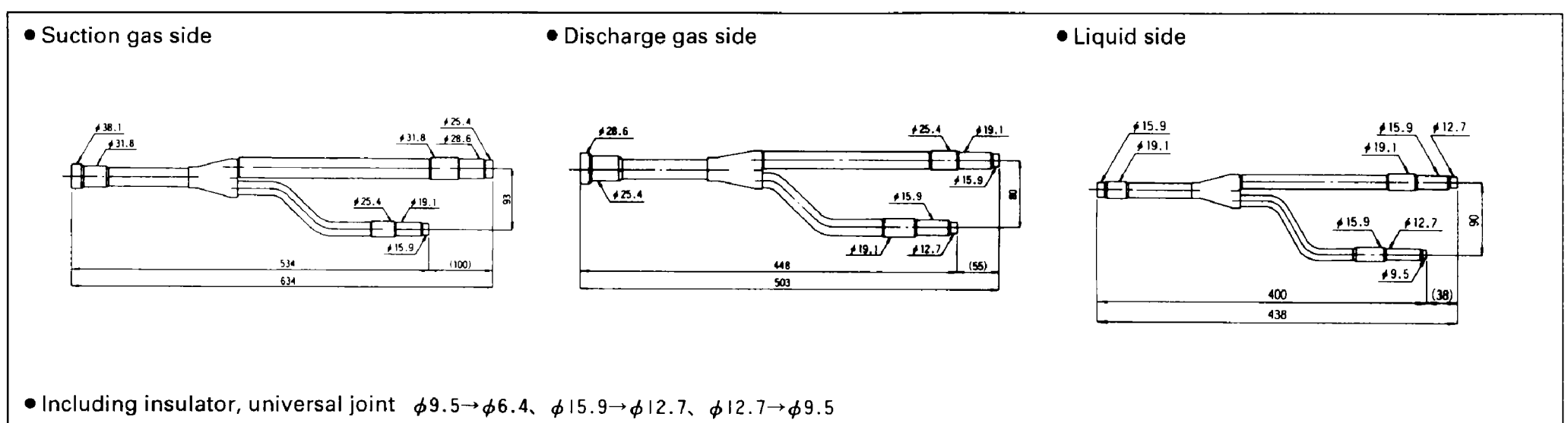

• KHRJ25K75T (640 or more)

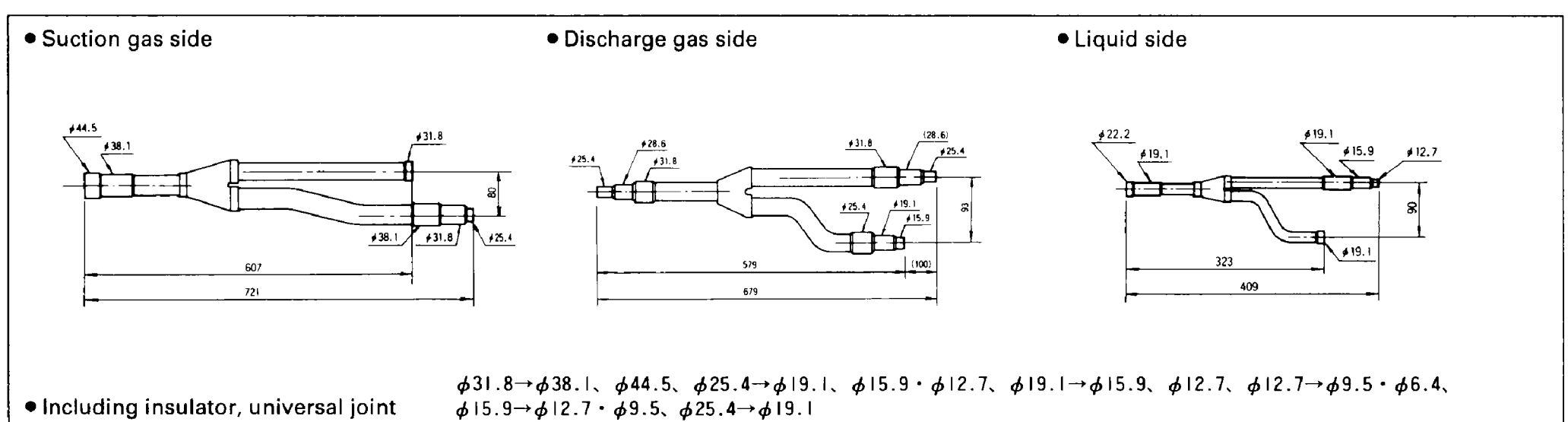

#### (4) REFNET HEADER (for heat recovery system)

- KHRJ25K18H (6 branch fitting) (less than 160)

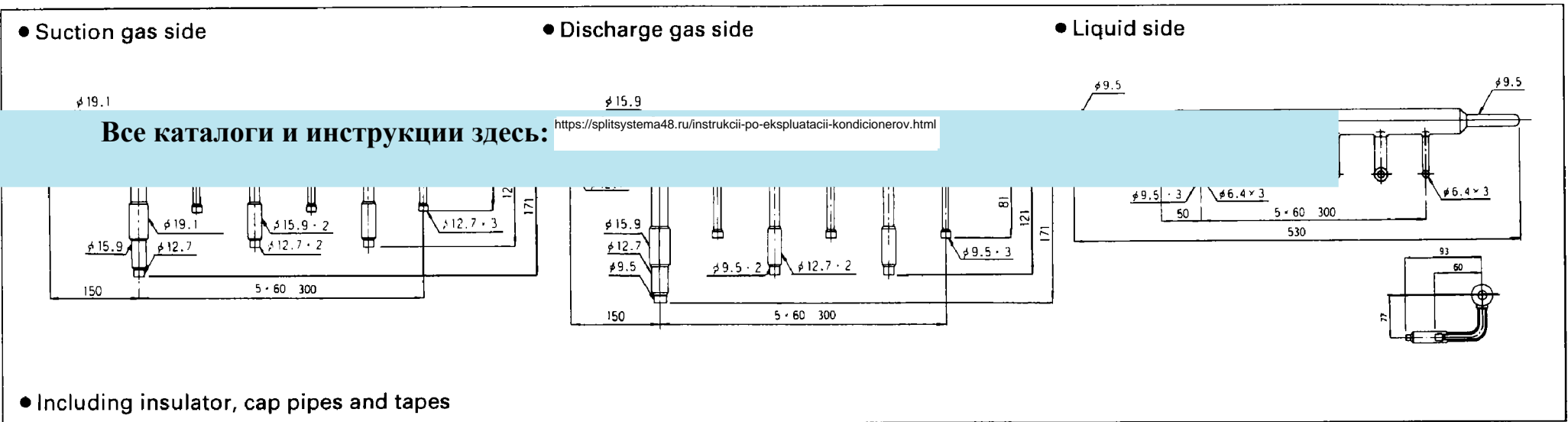

- KHRJ25K38H (8 branch fitting) (160 or more 330)

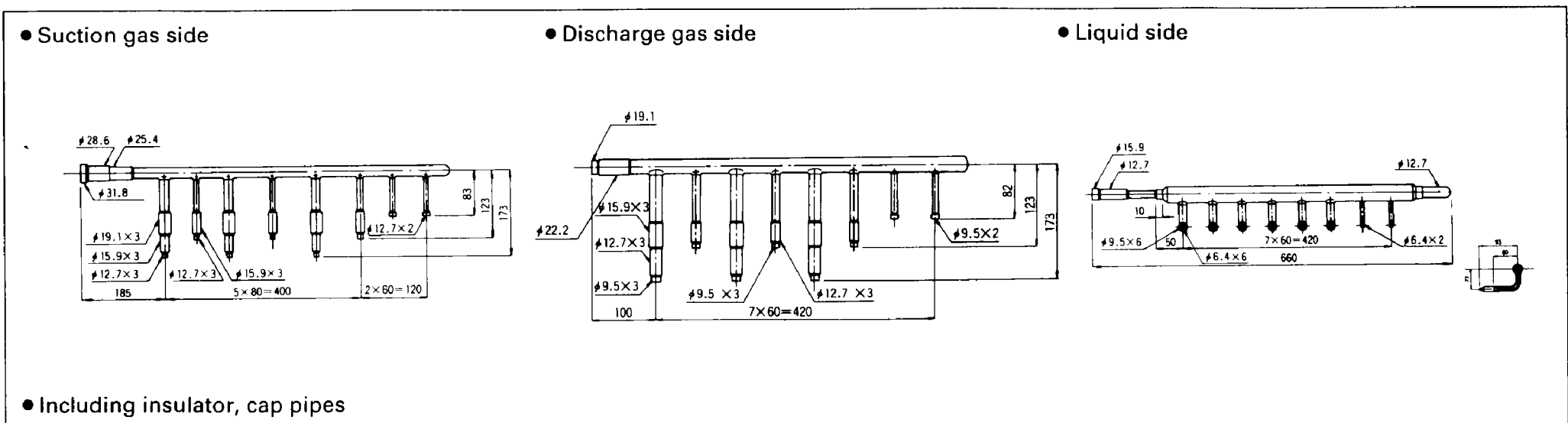

- KHRJ25K40H (8 branch fitting) (330 or more 640)

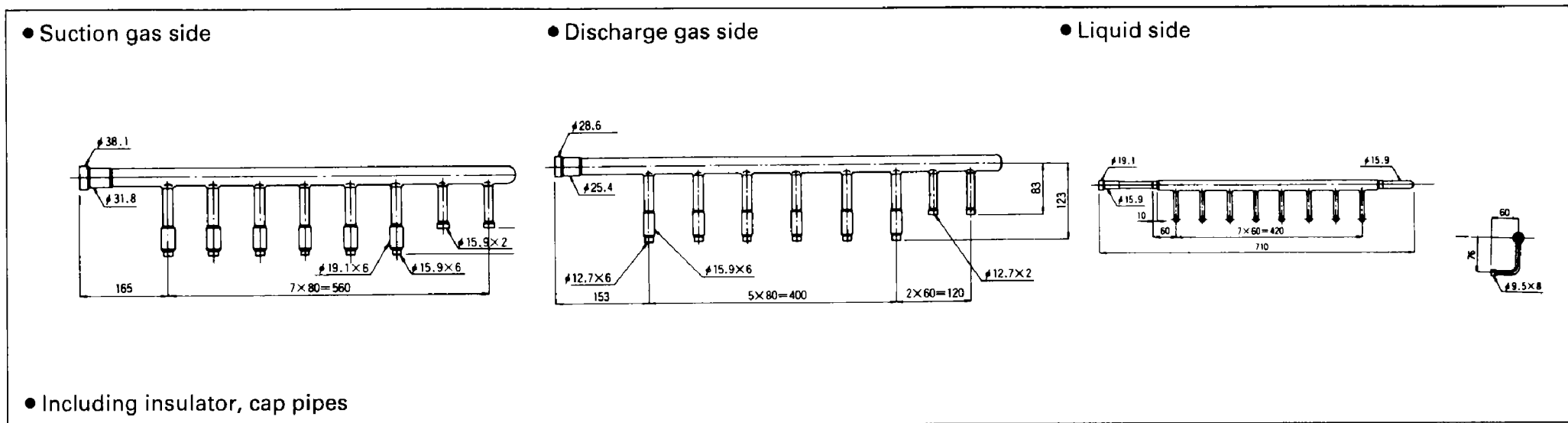



## (5) PIPE SIZE REDUCER

■ This kit including followings;

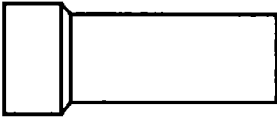
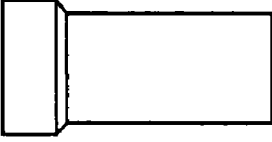
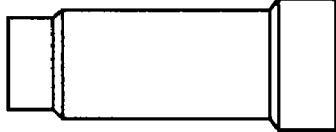
Name		Pipe size reducer ①	Pipe size reducer ②	Pipe size reducer ③
Figure				
Q'ty	KHRJ26K40TP	2	—	—
	KHRJ26K40HP	1	—	—
	KHRJ26K75TP	1	1	1
	KHRJ25K75TP	3	1	1

■ This kits are pipe size reducers for REFNET JOINT and HEADER and applicable to following REFNET CONNECTOR.

Kit Name	REFNET CONNECTOR
KHRJ26K40TP	KHRJ26K40T (Gas pipe) · KHRJ25K40T (Suction gas pipe)
KHRJ26K40HP	KHRJ26K40H (Gas pipe) · KHRJ25K40H (Suction gas pipe)
KHRJ26K75TP	KHRJ26K75T (Gas pipe)
KHRJ25K75TP	KHRJ25K75T ( Suction gas pipe ..... Pipe size reducer ①×1, ②×1, ③×3 ) Discharge gas pipe ... Pipe size reducer ①×2

The figure and size of pipe size reducers are as followings;

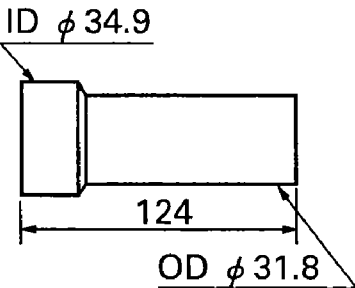
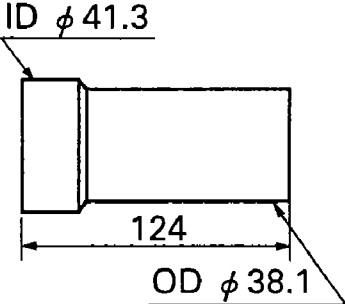
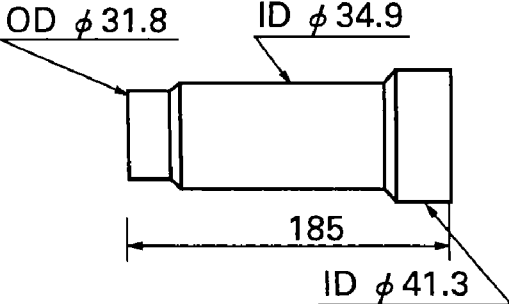
Pipe size reducer ①	Pipe size reducer ②	Pipe size reducer ③
		



Большая библиотека технической документации

<https://splitsystema48.ru/instrukcii-po-ekspluatacii-kondicionerov.html>

каталоги, инструкции, сервисные мануалы, схемы.